



# Huawei AirEngine 5760-22WD Remote Unit Datasheet

# Product Overview

Huawei AirEngine 5760-22WD is a Wi-Fi 6 (802.11ax) wall plate remote unit (RU). It can simultaneously provide services on 2.4 GHz (2x2 MIMO) and 5 GHz (4x4 MIMO) frequency bands, achieving a device rate of up to 5.37 Gbps. With mounting brackets, AirEngine 5760-22WD can be quickly installed on 86 mm, 118 mm, or 120 mm junction boxes and walls. Built-in smart antennas of the RU enable Wi-Fi signals to follow users, significantly enhancing users' wireless experiences. AirEngine 5760-22WD provides uplink optical and electrical ports, allowing customers to select different deployment modes and saving customers' investment. These strengths make AirEngine 5760-22WD ideal for scenarios with high-density rooms such as hotel guest rooms, dormitory rooms, and hospital wards.



AirEngine 5760-22WD

- Provides services simultaneously on both the 2.4 GHz and 5 GHz bands, at a rate of up to 574 Mbit/s at 2.4 GHz (2x2), 4.8Gbps at 5 GHz (4x4), and 5.37 Gbps for the device.
- Uplink: 1 x 2.5GE electrical, 1 x 10GE SPF+ ports; downlink: 4 x GE electrical and 2 x RJ45 pass-through.
- USB interface can be used for external power supply, external IoT expansion, and storage.
- Various installation modes for easy deployment, including wall-mounting and plate-mounting.
- Built-in smart antennas to provide precise coverage for STAs, reduce interference, and improve signal quality.
- Supports Bluetooth serial interface-based O&M through built-in Bluetooth and CloudCampus APP, and precise locating of Bluetooth terminals by collaborating with location server.
- PoE OUT supported by GE port, supplying power for STAs such as IP phones.

## NOTE

- *2.5GE electrical port can also support 100M/1000M rates.*
- *The AirEngine 5760-22WD cannot be installed on a ceiling.*

# Typical Networking

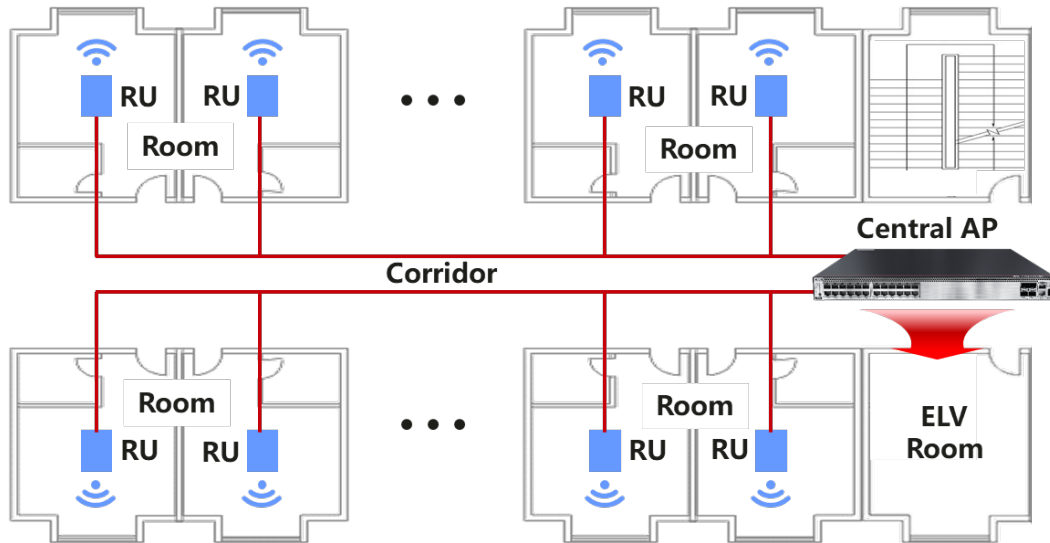

## NOTE

- A maximum of 48 RUs can be managed by working with the central AP AirEngine 9700D-M and a PoE switch.
- The RUs do not occupy AC licenses. The AC needs to manage only the AirEngine 9700D-M.

# Feature Descriptions

## Wi-Fi 6 (802.11ax) standard

- As the latest generation Wi-Fi standards of IEEE 802.11, 802.11ax improves user experience in high-density access scenarios and supports 2.4 GHz and 5 GHz frequency bands.
- UL/DL MU-MIMO on both the 2.4 GHz and 5 GHz frequency bands, allowing an AP to transmit data to and receive data from multiple STAs simultaneously and multiplying the utilization of radio spectrum resources
- 1024QAM modulation, improving data transmission efficiency by 25% compared with 802.11ac (256QAM).
- UL/DL OFDMA scheduling enables multiple users to receive and send information at the same time, reducing latency and improving network efficiency.
- Spatial reuse (SR) technology uses basic service set (BSS) coloring to enable APs and STAs to distinguish BSSs, minimizing co-channel interference.
- The target wake time (TWT)\* allows APs and STAs to negotiate the sleep and wake time with each other, thereby improving the battery life of the STAs.

## NOTE

- The function and features marked with \* can be implemented through software upgrade. The following describes are the same.

## UL/DL MU-MIMO

UL/DL MU-MIMO technology enables an AP to send data to multiple STAs simultaneously, which doubles the radio spectrum resource usage, increases the number of access users and bandwidth, and improves user experience in high-density access scenarios.

## Smart antenna array technology

The AP equipped with the dual-band smart antenna array and intelligent switchover algorithm can intelligently detect the application environment and access density, achieving more accurate signal coverage and interference suppression. This design helps provide the optimal signal coverage direction and signal quality for each mobile access STA, bringing seamless and smooth wireless network access experience to the users.

## High-speed access

The AP supports 160 MHz frequency bandwidth, which increases the number of available data subcarriers and expands transmission channels. In addition, the APs use 1024QAM modulation and MU-MIMO to achieve a rate of up to 4.8 Gbps on the 5 GHz band and 5.37 Gbps for the device.

## High Density Boost technology

Huawei uses the following technologies to address challenges in high-density scenarios, including access problems, data congestion, and poor roaming experience:

### SmartRadio for air interface optimization

- Load balancing during smart roaming: The load balancing algorithm can work during smart roaming for load balancing detection among APs on the network after STA roaming to adjust the STA load on each AP, improving network stability.
- Intelligent DFA technology: The dynamic frequency assignment (DFA) algorithm is used to automatically detect adjacent-channel and co-channel interference, and identify any 2.4 GHz redundant radio. Through automatic inter-AP negotiation, the redundant radio is automatically switched to another mode (dual-5G AP models support 2.4G-to-5G switchover) or is disabled to reduce 2.4 GHz co-channel interference and increase the system capacity.
- Intelligent conflict optimization technology: The dynamic enhanced distributed channel access (EDCA) and airtime scheduling algorithms are used to schedule the channel occupation time and service priority of each user. This ensures that each user is assigned relatively equal time for using channel resources and user services are scheduled in an orderly manner, improving service processing efficiency and user experience.

### Air interface performance optimization

- In high-density scenarios where many users access the network, increased number of low-rate STAs consumes more resources on the air interface, reduces the AP capacity, and lowers user experience. Therefore, Huawei APs will check the signal strength of STAs during access and rejects access from weak-signal STAs. At the same time, the APs monitor the rate of online STAs in real time and forcibly disconnect low-rate STAs so that the STAs can reassociate with APs that have stronger signals. The terminal access control technology can increase air interface use efficiency and allow access from more users.

### 5GHz-prior access (band steering)

- The APs support both 2.4G and 5G frequency bands. The 5GHz-prior access function enables an AP to steer STAs to the 5 GHz frequency band first, which reduces load and interference on the 2.4 GHz frequency band, improving the user experience.

## Wired and wireless dual security guarantee

To ensure data security, Huawei APs integrate wired and wireless security measures and provide comprehensive security protection.

### Authentication and encryption for wireless access

- The APs support WEP, WPA/WPA2-PSK, WPA3-SAE\*, WPA/WPA2-PPSK, WPA/WPA2/WPA3\*-802.1x, and WAPI\* authentication/encryption modes to ensure security of the wireless network. The authentication mechanism is used to authenticate user identities so that only authorized users can access network resources. The encryption mechanism is used to encrypt data transmitted over wireless links to ensure that the data can only be received and parsed by expected users.

### Analysis on no Wi-Fi interference sources\*

- Huawei APs can analyze the spectrum of no Wi-Fi interference sources and identify them, including baby monitors, Bluetooth devices, digital cordless phones (at 2.4 GHz frequency band only), wireless audio transmitters (at both the 2.4 GHz and 5 GHz frequency bands), wireless game controllers, and microwave ovens. Coupled with Huawei NCE-Campus, the precise locations of the interference sources can be detected, and the spectrum of them displayed, enabling the administrator to remove the interference in a timely manner.

### Rogue device monitoring

- Huawei APs support WIDS/WIPS, and can monitor, identify, defend, counter, and perform refined management on the rogue devices, to provide security guarantees for air interface environment and wireless data transmission.

### Wired access authentication and encryption for the AP

- The AP access control ensures validity of APs. The CAPWAP link protection and DTLS/IPsec encryption provide security assurance, improving data transmission security between the AP and the WLAN AC.

## Automatic application identification

Huawei APs support smart application control technology and can implement visualized control on Layer 4 to Layer 7 applications.

### Traffic identification

- Coupled with Huawei WLAN ACs, the APs can identify over 6000 common applications in various office scenarios. Based on the identification results, policy control can be implemented on user services, including priority adjustment, scheduling, blocking, and rate limiting to ensure efficient bandwidth resource use and improve quality of key services.

### Traffic statistics collection

- Traffic statistics of each application can be collected globally, by SSID, or by user, enabling the network administrator to know application use status on the network. The network administrator or operator can implement visualized control on service applications on smart terminals to enhance security and ensure effective bandwidth control.

## IoT extension

- The RU provides USB and PoE out interfaces to support IoT expansion such as Bluetooth, ZigBee, and RFID to implement short-distance and low-power IoT applications.

## Cloud-based Management

- With the central AP, it can be managed via cloud, eliminating the need to deploy a WLAN AC. In cloud-based management mode, abundant authentication functions, such as pre-shared key (PSK) authentication, Portal authentication, SMS authentication, and social media authentication, can be implemented with no authentication server. This mode significantly simplifies the networking and reduces the capital expenditure (CAPEX). In addition, multiple advanced functions, such as online cloud-based network planning, cloud-based deployment, cloud-based inspection, and cloud-based O&M, can be implemented through Huawei cloud management platform. In multi-branch deployment scenarios, cloud APs are pre-configured on the cloud management platform. During onsite network deployment, you only need to power on the cloud APs, connect them to the network ports of switches, and implement plug-and-play (PnP) of the APs by scanning the QR codes. The pre-configurations then are automatically delivered to the APs, significantly shortening the network deployment time. The cloud management platform can monitor the network status, device status, and STA connection status of all sites in a comprehensive and intuitive manner.

# Solution Features

## Easy to Manage

Remote units (RU) does not occupy AC licenses. The AC only needs to manage central APs, so nearly 10,000 rooms require merely about 200 APs.

## Flexible Deployment Modes Ensure Full Signal Coverage Without Coverage Holes

A central AP connects to indoor remote unit (RU) through network cables without wall penetration loss and feeder loss, implementing high-quality signal coverage.

## Long-Distance Coverage

Unlike the traditional distributed AP which allows for a maximum feeder length of 15 m, the central AP uses network cables to replace feeder cables and supports up to 100 m distance from the remote unit (RU). The network coverage range is therefore expanded by several times.

## Link Disconnection Survival

When the link between the central AP and AC disconnects, the central AP and Remote unit (RU) can maintain the current working states, preventing service interruptions of users and ensuring high-reliability transmission.

## Hierarchical Processing Technology, High Wireless Forwarding Capability

Huawei agile distributed Wi-Fi solution uses innovative hierarchical processing technology. The central AP manages Remote unit (RU) in a centralized manner and concurrently forwards service traffic, while the remote unit (RU) only process radio signals. The hierarchical design makes the network structure clearer and reduces the processing burden on the central AP and Remote unit (RU), improving efficiency and optimizing the overall wireless forwarding performance.

## Basic Specifications

Item	Description
WLAN features	<p><b>NOTE</b> <i>Cooperating with the central AP.</i></p> <p>Compliance with IEEE 802.11ax and compatibility with IEEE 802.11a/b/g/n/ac/ac Wave 2</p> <p>Providing 6 spatial streams, achieving up to 5.37 Gbps for the device</p> <p>Maximum ratio combining (MRC)</p> <p>Space time block code (STBC)</p> <p>Cyclic Delay Diversity (CDD)/Cyclic Shift Diversity (CSD)</p> <p>Beamforming</p> <p>DL/UL MU-MIMO</p> <p>DL/UL OFDMA</p> <p>Target wake time (TWT)*</p> <p>Compliance with 1024-QAM and compatibility with 256-QAM/64-QAM/16-QAM/8-QAM/QPSK/BPSK</p> <p>Low-density parity-check (LDPC)</p> <p>Frame aggregation, including A-MPDU (Tx/Rx) and A-MSDU (Tx/Rx)</p> <p>802.11 dynamic frequency selection (DFS)</p> <p>Short guard interval (GI) in 20 MHz, 40 MHz, 80 MHz, and 160 MHz modes</p> <p>Priority mapping and scheduling that are compliant with Wi-Fi multimedia (WMM) to implement priority-based data processing and forwarding. Automatic and manual rate adjustment (the rate is adjusted automatically by default)</p> <p>WLAN channel management and channel rate adjustment</p> <p><b>NOTE</b> <i>For detailed management channels, see the Country Code &amp; Channel Compliance Table.</i></p> <p>Automatic channel scanning and interference avoidance</p> <p>Service set identifier (SSID) hiding</p> <p>Signal sustain technology (SST)</p> <p>Unscheduled automatic power save delivery (U-APSD)</p> <p>Control and Provisioning of Wireless Access Points (CAPWAP) in Fit AP mode</p> <p>Automatic login in Fit AP mode</p> <p>Extended Service Set (ESS) in Fit AP mode</p> <p>Multi-user CAC</p> <p>802.11k and 802.11v smart roaming</p> <p>802.11r fast roaming (<math>\leq 50</math> ms)</p>
Network features	<p><b>NOTE</b> <i>Cooperating with the central AP.</i></p> <p>Compliance with IEEE 802.3ab</p> <p>Auto-negotiation of the rate and duplex mode and automatic switchover between the Media</p>

Item	Description
	<p>Dependent Interface (MDI) and Media Dependent Interface Crossover (MDI-X)</p> <p>Compliance with IEEE 802.1q</p> <p>SSID-based VLAN assignment</p> <p>VLAN trunk on uplink Ethernet ports</p> <p>Management channel of the AP uplink port in tagged and untagged mode</p> <p>DHCP client, obtaining IP addresses through DHCP</p> <p>Tunnel data forwarding and direct data forwarding</p> <p>Application identification and QoS classification when AP local forwarding (also called direct forwarding), which can significantly improve voice quality for applications such as Skype, QQ, and WeChat</p> <p>STA isolation in the same VLAN</p> <p>IPV4/IPV6 access control lists (ACLs)</p> <p>Link Layer Discovery Protocol (LLDP)</p> <p>Uninterrupted service forwarding upon CAPWAP channel disconnection in Fit AP mode</p> <p>Unified authentication on the AC</p> <p>AC dual-link backup</p> <p>IPv6</p> <p>Soft Generic Routing Encapsulation (GRE)</p> <p>IPv6 Source Address Validation Improvements (SAVI)</p> <p>Multicast Domain Name Service (mDNS) gateway protocol</p>
QoS features	<p><b>NOTE</b> <i>Cooperating with the central AP.</i></p> <p>WMM parameter management for each radio</p> <p>WMM power saving</p> <p>Priority mapping for upstream packets and flow-based mapping for downstream packets</p> <p>Queue mapping and scheduling</p> <p>User-based bandwidth limiting</p> <p>Adaptive bandwidth management (automatic bandwidth adjustment based on the user quantity and radio environment) to improve user experience</p> <p>Airtime scheduling</p> <p>Air interface HQoS scheduling</p>
Security features	<p><b>NOTE</b> <i>Cooperating with the central AP.</i></p> <p>Open system authentication</p> <p>WEP authentication/encryption using a 64-bit, 128-bit, 152-bit or 192-bit* encryption key</p> <p>WPA2-PSK authentication and encryption (WPA2 personal edition)</p> <p>WPA2-802.1X authentication and encryption (WPA2 enterprise edition)</p> <p>WPA3-SAE authentication and encryption (WPA3 personal edition)*</p> <p>WPA3-802.1X authentication and encryption (WPA3 enterprise edition)*</p> <p>WPA-WPA2 hybrid authentication</p> <p>WPA2-WPA3 hybrid authentication*</p> <p><b>NOTE</b> <i>This function can be implemented through software upgrades.</i></p> <p>WPA2-PPSK authentication and encryption in Fit AP mode</p> <p>WAPI authentication and encryption</p>

Item	Description
	<p>Wireless intrusion detection system (WIDS) and wireless intrusion prevention system (WIPS), including rogue device detection and countermeasure, attack detection and dynamic blacklist, and STA/AP blacklist and whitelist</p> <p>802.1x authentication, MAC address authentication, and Portal authentication</p> <p>DHCP snooping</p> <p>Dynamic ARP Inspection (DAI)</p> <p>IP Source Guard (IPSG)</p> <p>802.11w Protected Management Frames (PMFs)</p>
Maintenance features	<p><b>NOTE</b> <i>Cooperating with the central AP.</i></p> <p>Unified management and maintenance on the AC in Fit AP mode</p> <p>Automatic login and configuration loading, and plug-and-play (PnP) in Fit AP mode</p> <p>Batch upgrade in Fit AP mode</p> <p>Telnet</p> <p>STelnet using SSH v2</p> <p>SFTP using SSH v2</p> <p>Remote wireless O&amp;M through the Bluetooth console port</p> <p>Web local AP management through HTTP or HTTPS in Fat AP mode</p> <p>Real-time configuration monitoring and fast fault location using the NMS</p> <p>SNMP v1/v2/v3 in Fat AP mode</p> <p>System status alarm</p> <p>Network Time Protocol (NTP) in Fat AP mode</p>
BYOD	<p><b>NOTE</b> <i>The AP supports bring your own device (BYOD) only in Fit AP mode, cooperating with the central AP.</i></p> <p>Identifies the device type according to the organizationally unique identifier (OUI) in the MAC address.</p> <p>Identifies the device type according to the user agent (UA) information in an HTTP packet.</p> <p>Identifies the device type according to DHCP options.</p> <p>The RADIUS server delivers packet forwarding, security, and QoS policies according to the device type carried in the RADIUS authentication and accounting packets.</p>
Location service	<p><b>NOTE</b> <i>The AP supports bring your own device (BYOD) only in Fit AP mode, cooperating with the central AP.</i></p> <p>Identifies the device type according to the organizationally unique identifier (OUI) in the MAC address.</p> <p>Identifies the device type according to the user agent (UA) information in an HTTP packet.</p> <p>Identifies the device type according to DHCP options.</p> <p>The RADIUS server delivers packet forwarding, security, and QoS policies according to the device type carried in the RADIUS authentication and accounting packets.</p>
Spectrum analysis*	<p><b>NOTE</b> <i>The AP supports bring your own device (BYOD) only in Fit AP mode, cooperating with the central AP.</i></p> <p>Identification of more than eight interference sources including Bluetooth devices, microwave ovens, cordless phones, ZigBee devices, game controllers, 2.4 GHz/5 GHz wireless video and audio devices, and baby monitors</p> <p>Working with the location server to locate interference sources and perform spectrum analysis on</p>



Item	Description
	them

## Technical Specifications

Item	Description	
Technical specifications	Dimensions (H x W x D)	170 x 86 x 74mm
	Weight	0.7 kg
	Interface type	Up link: 1 x 2.5GE+ 1 x 10GE SFP+ Down link: 4 x GE 1 x USB interface Pass Through: 2xRJ45 <b>NOTE</b> <ul style="list-style-type: none"> <li>2.5GE electrical port can also support 100M/1000M rates.</li> <li>GE3/PoE_Out: Supports PoE output.</li> <li>Pass Through: Connects to a network cable or phone cable for transparent transmission.</li> </ul>
	IoT expansion	External IoT module extension by USB or PoE out
	Bluetooth	Build in BLE5.0
	LED indicator	Indicates the power-on, startup, running, alarm, and fault states of the system.
Power specifications	Power input	PoE power supply: In compliance with 802.3at/bt.
	PoE out	Support PoE out
	Maximum power consumption	<ul style="list-style-type: none"> <li>802.3bt power supply: 25.3 W (excluding USB and PoE_OUT)</li> <li>802.3at power supply: 25.3 W (excluding USB and PoE_OUT)</li> </ul> <b>NOTE</b> <i>For details about the working status of the Ethernet port, PoE out and USB in different power supply modes, see the <a href="#">Specification Query Tool</a>.</i> <i>The actual maximum power consumption depends on local laws and regulations.</i>
Environmental specifications	Operating temperature	0°C to +40°C
	Storage temperature	-40°C to +70°C
	Operating humidity	5% to 95% (non-condensing)
	Altitude	-60 m to +5000 m
	Atmospheric pressure	53 kPa to 106 kPa
Radio specifications	Antenna type	Built-in smart antennas
	Antenna gain	2.4GHz: 3.5dBi 5GHz: 5dBi <b>NOTE</b> <ul style="list-style-type: none"> <li>The gains above are the single-antenna peak gains.</li> <li>The equivalent antenna gain after all 2.4 GHz or 5 GHz antennas are combined is 1.6 dBi in 2.4 GHz or 1.5 dBi in 5</li> </ul>

Item		Description
		GHz.
	Maximum number of SSIDs for each radio	≤ 16
	Maximum number of users	≤ 1024 <b>NOTE</b> <i>The actual number of users varies according to the environment.</i>
	Maximum transmit power	2.4GHz: 23dBm (combined power) 5GHz: 26dBm (combined power) <b>NOTE</b> <i>The actual transmit power depends on local laws and regulations.</i>
	Power increment	1 dBm
	Maximum number of non-overlapping channels	2.4 GHz (2.412 GHz to 2.472 GHz) <ul style="list-style-type: none"> <li>• 802.11b/g               <ul style="list-style-type: none"> <li>- 20 MHz: 3</li> </ul> </li> <li>• 802.11n               <ul style="list-style-type: none"> <li>- 20 MHz: 3</li> <li>- 40 MHz: 1</li> </ul> </li> <li>• 802.11ax               <ul style="list-style-type: none"> <li>- 20 MHz: 3</li> <li>- 40 MHz: 1</li> </ul> </li> </ul> 5 GHz (5.18 GHz to 5.825 GHz) <ul style="list-style-type: none"> <li>• 802.11a               <ul style="list-style-type: none"> <li>- 20 MHz: 13</li> </ul> </li> <li>• 802.11n               <ul style="list-style-type: none"> <li>- 20 MHz: 13</li> <li>- 40 MHz: 6</li> </ul> </li> <li>• 802.11ac               <ul style="list-style-type: none"> <li>- 20 MHz: 13</li> <li>- 40 MHz: 6</li> <li>- 80 MHz: 3</li> <li>- 160 MHz: 1</li> </ul> </li> <li>• 802.11ax               <ul style="list-style-type: none"> <li>- 20 MHz: 13</li> <li>- 40 MHz: 6</li> <li>- 80 MHz: 3</li> <li>- 160 MHz: 1</li> </ul> </li> </ul> <b>NOTE</b> <i>The table uses the number of non-overlapping channels supported by China as an example. The number of non-overlapping channels varies in different countries. For details, see the Country Codes &amp; Channels Compliance</i>
	Receiver sensitivity	<ul style="list-style-type: none"> <li>• 2.4GHz 802.11b: -100dBm/1Mbit/s;-97dBm/2Mbit/s;-94dBm/5.5Mbit/s;-91dBm/11Mbit/s;</li> <li>• 2.4GHz 802.11g: -100dBm/6Mbit/s;-97dBm/9Mbit/s;-</li> </ul>

Item	Description
	<p>95dBm/12Mbit/s;-93dBm/18Mbit/s;-90dBm/24Mbit/s;-87dBm/36Mbit/s;-83dBm/48Mbit/s;-81dBm/54Mbit/s;</p> <ul style="list-style-type: none"> <li>• 2.4GHz 802.11n(HT20): -99dBm/MCS0;-97dBm/MCS1;-95dBm/MCS2;-92dBm/MCS3;-89dBm/MCS4;-85dBm/MCS5;-82dBm/MCS6;-81dBm/MCS7;</li> <li>• 2.4GHz 802.11n(HT40): -96dBm/MCS0;-95dBm/MCS1;-92dBm/MCS2;-89dBm/MCS3;-86dBm/MCS4;-82dBm/MCS5;-80dBm/MCS6;-79dBm/MCS7;</li> <li>• 2.4GHz 802.11ac(VHT20): -99dBm/MCS0NSS1;-97dBm/MCS1NSS1;-95dBm/MCS2NSS1;-92dBm/MCS3NSS1;-89dBm/MCS4NSS1;-85dBm/MCS5NSS1;-82dBm/MCS6NSS1;-81dBm/MCS7NSS1;-78dBm/MCS8NSS1;</li> <li>• 2.4GHz 802.11ac(VHT40): -96dBm/MCS0NSS1;-95dBm/MCS1NSS1;-92dBm/MCS2NSS1;-89dBm/MCS3NSS1;-86dBm/MCS4NSS1;-82dBm/MCS5NSS1;-80dBm/MCS6NSS1;-79dBm/MCS7NSS1;-74dBm/MCS8NSS1;-72dBm/MCS9NSS1;</li> <li>• 2.4GHz 802.11ax(HT20): -99dBm/MCS0NSS1;-97dBm/MCS1NSS1;-95dBm/MCS2NSS1;-92dBm/MCS3NSS1;-89dBm/MCS4NSS1;-85dBm/MCS5NSS1;-82dBm/MCS6NSS1;-81dBm/MCS7NSS1;-78dBm/MCS8NSS1;-75dBm/MCS9NSS1;-73dBm/MCS10NSS1;-71dBm/MCS11NSS1;</li> <li>• 2.4GHz 802.11ax(HT40): -96dBm/MCS0NSS1;-95dBm/MCS1NSS1;-92dBm/MCS2NSS1;-89dBm/MCS3NSS1;-86dBm/MCS4NSS1;-82dBm/MCS5NSS1;-80dBm/MCS6NSS1;-79dBm/MCS7NSS1;-74dBm/MCS8NSS1;-72dBm/MCS9NSS1;-69dBm/MCS10NSS1;-67dBm/MCS11NSS1;</li> <li>• 5GHz 802.11a: -99dBm/6Mbit/s;-97dBm/9Mbit/s;-96dBm/12Mbit/s;-94dBm/18Mbit/s;-91dBm/24Mbit/s;-88dBm/36Mbit/s;-84dBm/48Mbit/s;-81dBm/54Mbit/s;</li> <li>• 5GHz 802.11n(HT20): -98dBm/MCS0;-95dBm/MCS1;-93dBm/MCS2;-90dBm/MCS3;-87dBm/MCS4;-83dBm/MCS5;-81dBm/MCS6;-80dBm/MCS7;</li> <li>• 5GHz 802.11n(HT40): -96dBm/MCS0;-95dBm/MCS1;-93dBm/MCS2;-88dBm/MCS3;-85dBm/MCS4;-83dBm/MCS5;-80dBm/MCS6;-78dBm/MCS7;</li> <li>• 5GHz 802.11ac(VHT20): -98dBm/MCS0NSS1;-95dBm/MCS1NSS1;-93dBm/MCS2NSS1;-90dBm/MCS3NSS1;-87dBm/MCS4NSS1;-83dBm/MCS5NSS1;-81dBm/MCS6NSS1;-80dBm/MCS7NSS1;-77dBm/MCS8NSS1;</li> <li>• 5GHz 802.11ac(VHT40): -96dBm/MCS0NSS1;-95dBm/MCS1NSS1;-93dBm/MCS2NSS1;-88dBm/MCS3NSS1;-85dBm/MCS4NSS1;-83dBm/MCS5NSS1;-80dBm/MCS6NSS1;-78dBm/MCS7NSS1;-75dBm/MCS8NSS1;-73dBm/MCS9NSS1;</li> <li>• 5GHz 802.11ac(VHT80): -93dBm/MCS0NSS1;-90dBm/MCS1NSS1;-88dBm/MCS2NSS1;-85dBm/MCS3NSS1;-83dBm/MCS4NSS1;-80dBm/MCS5NSS1;-78dBm/MCS6NSS1;-</li> </ul>

Item	Description
	<p>76dBm/MCS7NSS1;-72dBm/MCS8NSS1;-70dBm/MCS9NSS1;</p> <ul style="list-style-type: none"> <li>• 5GHz 802.11ac(VHT160): -90dBm/MCS0NSS1;-87dBm/MCS1NSS1;-85dBm/MCS2NSS1;-82dBm/MCS3NSS1;-79dBm/MCS4NSS1;-75dBm/MCS5NSS1;-73dBm/MCS6NSS1;-70dBm/MCS7NSS1;-68dBm/MCS8NSS1;-66dBm/MCS9NSS1;</li> <li>• 5GHz 802.11ax(HT20): -98dBm/MCS0NSS1;-95dBm/MCS1NSS1;-93dBm/MCS2NSS1;-90dBm/MCS3NSS1;-87dBm/MCS4NSS1;-83dBm/MCS5NSS1;-81dBm/MCS6NSS1;-80dBm/MCS7NSS1;-77dBm/MCS8NSS1;-75dBm/MCS9NSS1;-73dBm/MCS8NSS1;-70dBm/MCS9NSS1;</li> <li>• 5GHz 802.11ax(HT40): -96dBm/MCS0NSS1;-95dBm/MCS1NSS1;-93dBm/MCS2NSS1;-88dBm/MCS3NSS1;-85dBm/MCS4NSS1;-83dBm/MCS5NSS1;-80dBm/MCS6NSS1;-78dBm/MCS7NSS1;-75dBm/MCS8NSS1;-73dBm/MCS9NSS1;-70dBm/MCS8NSS1;-67dBm/MCS9NSS1;</li> <li>• 5GHz 802.11ax(HT80): -93dBm/MCS0NSS1;-90dBm/MCS1NSS1;-88dBm/MCS2NSS1;-85dBm/MCS3NSS1;-83dBm/MCS4NSS1;-80dBm/MCS5NSS1;-78dBm/MCS6NSS1;-76dBm/MCS7NSS1;-72dBm/MCS8NSS1;-70dBm/MCS9NSS1;-67dBm/MCS10NSS1;-65dBm/MCS11NSS1;</li> <li>• 5GHz 802.11ax(HT160): -90dBm/MCS0NSS1;-87dBm/MCS1NSS1;-85dBm/MCS2NSS1;-82dBm/MCS3NSS1;-79dBm/MCS4NSS1;-75dBm/MCS5NSS1;-73dBm/MCS6NSS1;-70dBm/MCS7NSS1;-67dBm/MCS8NSS1;-66dBm/MCS9NSS1;-62dBm/MCS10NSS1;-60dBm/MCS11NSS1;</li> </ul>

## Standards Compliance

Item	Description		
Safety standards	UL 62368-1 EN 62368-1 IEC 62368-1	GB 4943 EN 60950-1 UL 60950-1	CAN/CSA 22.2 No.60950-1 IEC 60950-1
Radio standards	ETSI EN 300 328 ETSI EN 301 893	RSS-210	AS/NZS 4268
EMC standards	EN 301 489-1 EN 301 489-17 ETSI EN 60601-1-2 FCC Part 15 ICES-003 YD/T 1312.2-2004	ITU k.20 GB 9254 GB 17625.1 AS/NZS CISPR22 EN 55022	EN 55024 CISPR 22 CISPR 24 IEC61000-4-6 IEC61000-4-2
IEEE standards	IEEE 802.11a/b/g IEEE 802.11n	IEEE 802.11h IEEE 802.11d	IEEE 802.11u IEEE 802.11v

Item	Description		
	IEEE 802.11ac IEEE 802.11ax	IEEE 802.11e IEEE 802.11k	IEEE 802.11w IEEE 802.11r
Security standards	<ul style="list-style-type: none"> <li>802.11i, Wi-Fi Protected Access 2(WPA2), WPA, WPA2, WPA2-Enterprise, WPA2-PSK, WPA3*, WAPI*</li> <li>802.1X</li> <li>Advanced Encryption Standards(AES), Temporal Key Integrity Protocol(TKIP), WEP, Open</li> <li>EAP Type(s)</li> </ul>		
EMF	CENELEC EN 62311 CENELEC EN 50385	OET65 RSS-102	FCC Part1&2 FCC KDB Series
RoHS	Directive 2002/95/EC & 2011/65/EU		
Reach	Regulation 1907/2006/EC		
WEEE	Directive 2002/96/EC & 2012/19/EU		

## Antennas Pattern

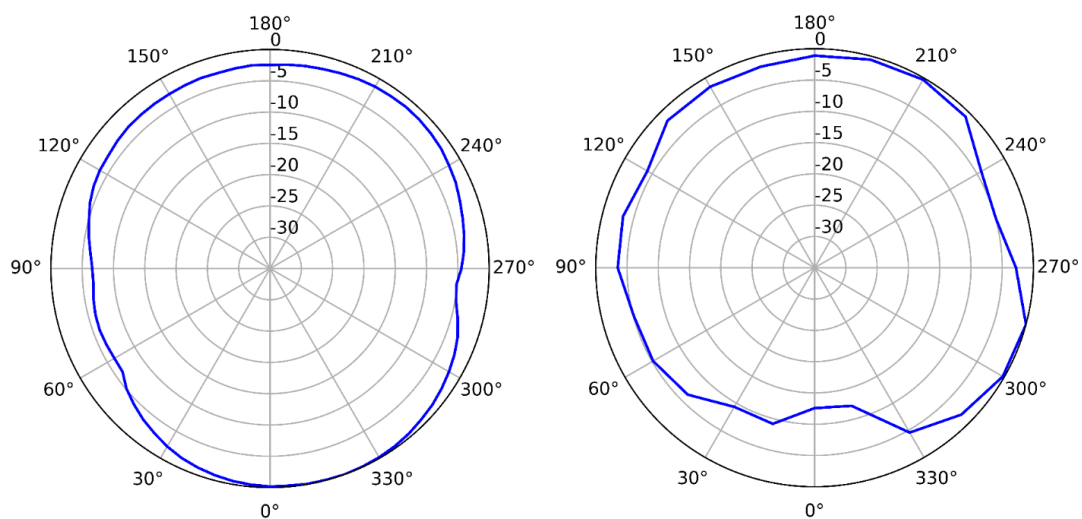

2.4G (Horizontal)

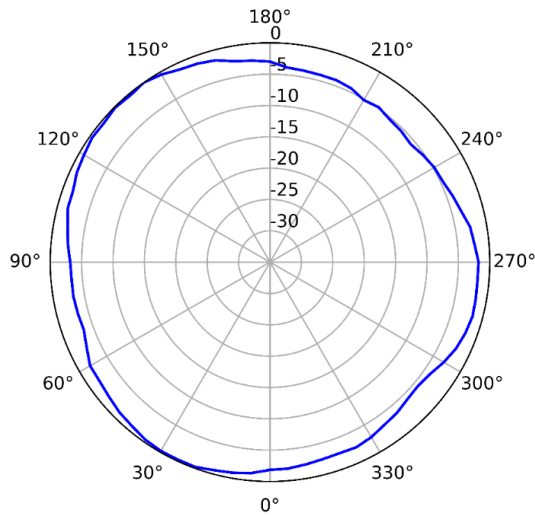

2.4G (Vertical)

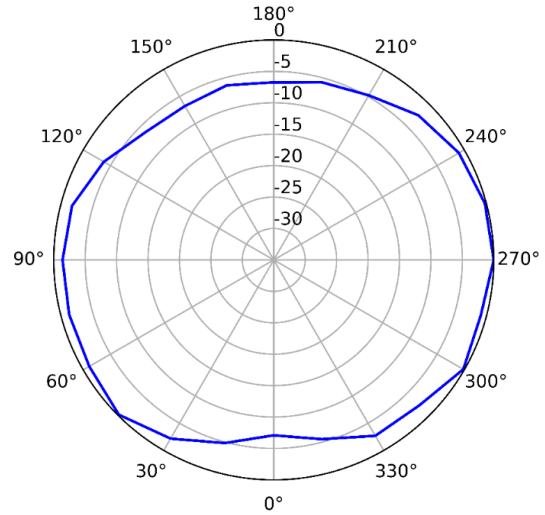

5G (Horizontal)



5G (Vertical)



## More Information

For more information about Huawei WLAN products, visit <http://e.huawei.com> or contact us in the following ways:

- Global service hotline: <http://e.huawei.com/en/service-hotline>
- Logging in to the Huawei Enterprise technical support web: <http://support.huawei.com/enterprise/>
- Sending an email to the customer service mailbox: [support\\_e@huawei.com](mailto:support_e@huawei.com)

**Copyright © Huawei Technologies Co., Ltd. 2020. All rights reserved.**

No part of this document may be reproduced or transmitted in any form or by any means without prior written consent of Huawei Technologies Co., Ltd.

#### **Trademarks and Permissions**



HUAWEI and other Huawei trademarks are trademarks of Huawei Technologies Co., Ltd.

All other trademarks and trade names mentioned in this document are the property of their respective holders.

#### **Notice**

The purchased products, services and features are stipulated by the contract made between Huawei and the customer. All or part of the products, services and features described in this document may not be within the purchase scope or the usage scope. Unless otherwise specified in the contract, all statements, information, and recommendations in this document are provided "AS IS" without warranties, guarantees or representations of any kind, either express or implied.

The information in this document is subject to change without notice. Every effort has been made in the preparation of this document to ensure accuracy of the contents, but all statements, information, and recommendations in this document do not constitute a warranty of any kind, express or implied.

#### **Huawei Technologies Co., Ltd.**

Address: Huawei Industrial Base Bantian, Longgang Shenzhen 518129 People's Republic of China

Website: [www.huawei.com](http://www.huawei.com)