

**EDFA0820-D
V100R019C00**

Product Description

Issue 04
Date 2019-03-15



Copyright © Huawei Technologies Co., Ltd. 2019. All rights reserved.

No part of this document may be reproduced or transmitted in any form or by any means without prior written consent of Huawei Technologies Co., Ltd.

Trademarks and Permissions



HUAWEI and other Huawei trademarks are trademarks of Huawei Technologies Co., Ltd.

All other trademarks and trade names mentioned in this document are the property of their respective holders.

Notice

The purchased products, services and features are stipulated by the contract made between Huawei and the customer. All or part of the products, services and features described in this document may not be within the purchase scope or the usage scope. Unless otherwise specified in the contract, all statements, information, and recommendations in this document are provided "AS IS" without warranties, guarantees or representations of any kind, either express or implied.

The information in this document is subject to change without notice. Every effort has been made in the preparation of this document to ensure accuracy of the contents, but all statements, information, and recommendations in this document do not constitute a warranty of any kind, express or implied.

Huawei Technologies Co., Ltd.

Address: Huawei Industrial Base
Bantian, Longgang
Shenzhen 518129
People's Republic of China

Website: <http://www.huawei.com>

Email: support@huawei.com

About This Document

Version

The following table lists the product version related to this document.

Product Name	Version
EDFA0820-D(EDFA for short)	V100R019C00
iManager U2000(U2000 for short)	V200R018C50

Change History

Changes between document issues are cumulative. The latest document issue contains all the changes made in earlier issues.

Issue	Date	Description
04	2019-03-15	Optimized some figures.
03	2018-12-03	The power type is added to the Table 4-1 .
02	2018-07-02	A NOTE which suggesting to use an external modulation optical transmitter is added in Application Scenario .
01	2018-04-20	This issue is the first official release.

Contents

About This Document.....	ii
1 Product Overview.....	1
1.1 Product Positioning.....	1
1.2 Product Highlights.....	2
2 Functions and Features.....	3
3 Product Structure.....	6
3.1 Overview.....	6
3.2 Service Module.....	6
3.3 Fan Module.....	8
4 Technical Specifications.....	10
5 iManager U2000.....	16
A Acronyms and Abbreviations.....	20

1 Product Overview

1.1 Product Positioning

The EDFA is designed for multiple system operators (MSOs). It is an amplifying and multiplexing product that supports both the cable TV (CATV) and broadband services. Specifically, it amplifies a channel of CATV signals, divides the signals into 8 channels, multiplexes the 8 channels of CATV signals with 8 channels of PON signals, and transmits the multiplexed signals over the optical distribution network (ODN) to users' homes.

Application Scenario

The EDFA is applicable in the CATV+PON fiber to the building (FTTB) and fiber to the home (FTTH) scenarios. **Figure 1-1** shows the networking for CATV+PON FTTB and FTTH.

Figure 1-1 Networking for CATV+PON FTTB and FTTH

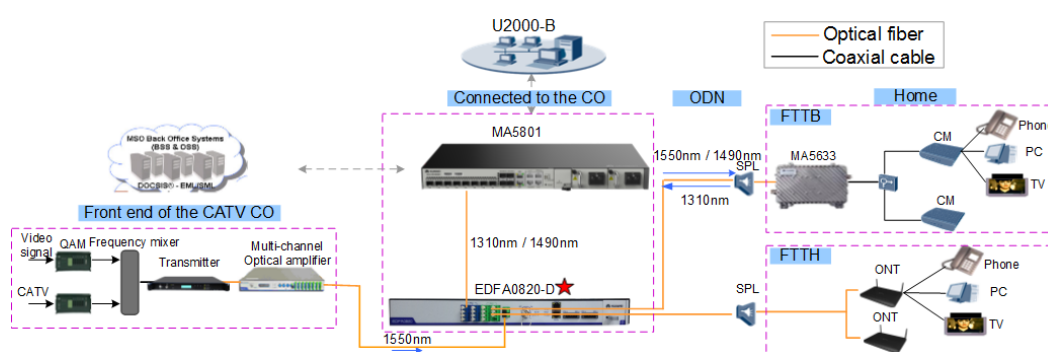

The CATV+PON FTTB and FTTH networking has the following advantages:

- Flexible provisioning of multiple services, including voice, IPTV, and private line services
- 100 M/1000 M to the desktop
- Single ONT supporting multiple services by employing the single-fiber triple-wavelength technology, minimizing investments
- Unified management for devices deployed networkwide

 **NOTE**

The EDFA device is a high-power amplifier product. It has high requirements on the suppression capability of the Stimulated Brillouin Scattering (SBS) of the front-end optical transmitter (the SBS threshold cannot be less than 16 dBm). It is recommended that an external modulation optical transmitter with better SBS suppression capability be used.

1.2 Product Highlights

Good adaptability

- Supports the installation in an indoor 19- or 21-inch cabinet (for example, Huawei N66B) or an outdoor cabinet, such as Huawei T100 or H100 cabinet.
- Supports remote management and control.

Proper structure

- High integration requiring minimum external fiber routing and low installation cost.

High reliability

- With a carrier-class EDFA module, supporting a high operating temperature of 65°C.
- Good heat dissipation with air ventilated from the left to the right side of the device.

High security

- Adapters slanted 60° on the left for eye protection.
- Dual power inputs for backup, ensuring line security

Environment-friendly

- Complies with the European Union (EU) RoHS standards.

2 Functions and Features

This topic describes the main functions and features of the EDFA, including communication interfaces, device configuration management, and device alarm and event management.

Main Functions and Function Implementation

The EDFA amplifies CATV signals, splits the signals into 8 channels, and multiplexes them with 8 channels of PON signals. The adjustable CATV output power ranges from 15.5 dBm to 20.5 dBm (working wavelength: 1550 nm). The default output power is 20.0 dBm (output power consistency: from - 0.5 dB to +0.5 dB).

The EDFA integrates the EDFA amplifier, optical splitter, and 8-channel WDM in one module. The following figure shows the implementation principle of the EDFA.

Figure 2-1 EDFA0820-D implementation principle

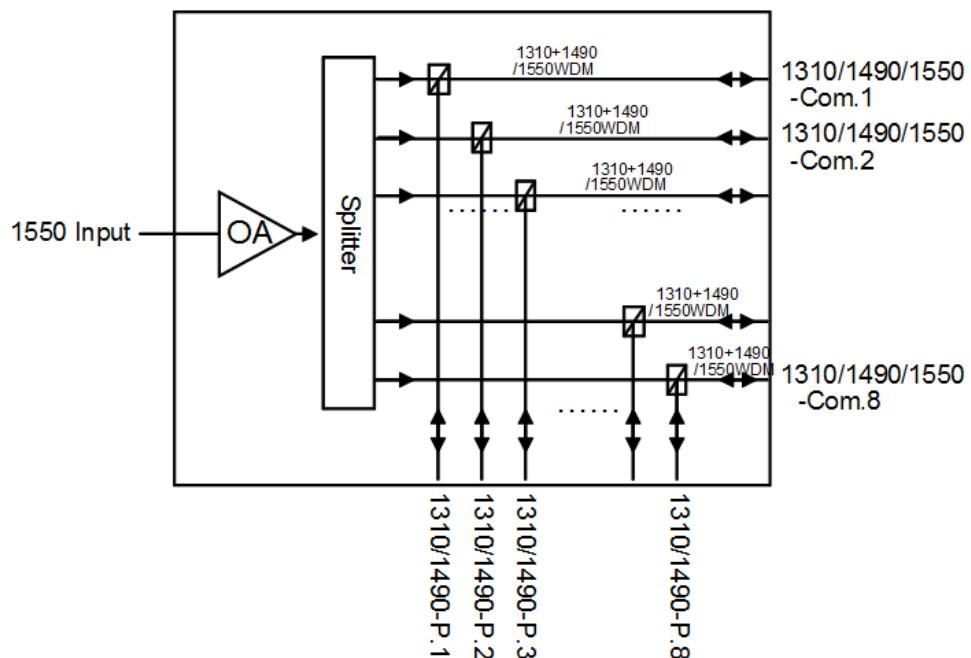

Communication Port

The device provides the COM serial port and Ethernet port, which are described in [Table 2-1](#).

Table 2-1 Description of communication ports

Port Type	Description
COM serial port	<ul style="list-style-type: none"> ● The port is configured with a 9600 bps communication rate (default setting), 8 data bits, 1 stop bit, and 0 parity bit. ● The port type is RJ-45.
Ethernet port	<ul style="list-style-type: none"> ● An Ethernet electrical port that supports 10M/100M autonegotiation is provided. ● The port type is RJ-45, and each port has an indicator. ● The port supports TCP/IP and SNMP. ● All communication ports support basic authentication to prevent unauthorized connections. ● An SNMP connection can be established between the port and the U2000 for device access. ● A connection can be established between the port and the U2000 client for information obtaining and device control. ● Telnet management is supported (disabled by default).

Configuration and Management

The EDFA input and output parameters, and PUMP parameters can be configured through the U2000 or CLI. The following table lists the configurable parameters.

Table 2-2 List of configuration parameters

Configurable Parameter		Description
EDFA Parameters	APC Power	Indicates the output optical power of the EDFA. This parameter can be used to adjust the output optical power of the EDFA.
	Output Power Threshold	Indicates the low output optical power alarm threshold for the EDFA. When the output optical power of the EDFA is lower than this threshold, an EDFA Output Power alarm is reported.
	Input Power Low Threshold	Indicates the low input optical power alarm threshold for the EDFA. When the input optical power of the EDFA is lower than this threshold, an EDFA Input Power alarm is reported.
	Input Power Los Threshold	Indicates the low input optical power PUMP shutdown threshold of the EDFA. When the input optical power of the EDFA is lower than this threshold, an EDFA Input Los alarm is reported.

Configurable Parameter		Description
PUMP Parameters	Pump01 Current Threshold	Indicates the operating current alarm threshold for PUMP01. When the operating current of PUMP01 is higher than this threshold, an EDFA Pump1 alarm is reported.
	Pump01 Temperature Threshold	Indicates the operating temperature alarm threshold for PUMP01. When the operating temperature of PUMP01 is higher than this threshold, an EDFA Pump1 alarm is reported.
	Pump02 Current Threshold	Indicates the operating current alarm threshold for PUMP02. When the operating current of PUMP02 is higher than this threshold, an EDFA Pump2 alarm is reported.
	Pump02 Temperature Threshold	Indicates the operating temperature alarm threshold for PUMP02. When the operating temperature of PUMP02 is higher than this threshold, an EDFA Pump2 alarm is reported.

Alarm and Event Management

1. The device provides an alarm management application programming interface (API) to monitor the device status.
2. The device supports proactive alarm reporting.
3. The device supports the following alarms and events:
 - a. Power failure
 - b. Fan failure
 - c. Abnormal hardware status
 - d. Software exception
 - e. Failures that may affect operations

3 Product Structure

3.1 Overview

The EDFA includes 2 modules: service module and fan module, as shown in [Figure 3-1](#).

Figure 3-1 EDFA0820-D structure

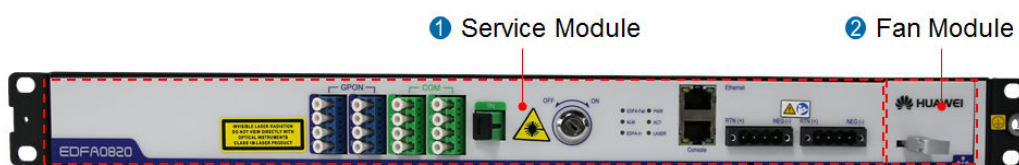

3.2 Service Module

The service module includes 5 parts: optical ports, key switch, indicators, communication ports, and power input. The service module manages all the internal communications of the device, detects the availability status of the sub-modules, and obtains the operating status of the entire device. The iManager U2000 can send configuration commands to the service module for remote management. For details, see [Table 3-1](#), [Table 3-2](#), [Table 3-3](#), [Figure 3-3](#) and [Figure 3-4](#).

Figure 3-2 Service module

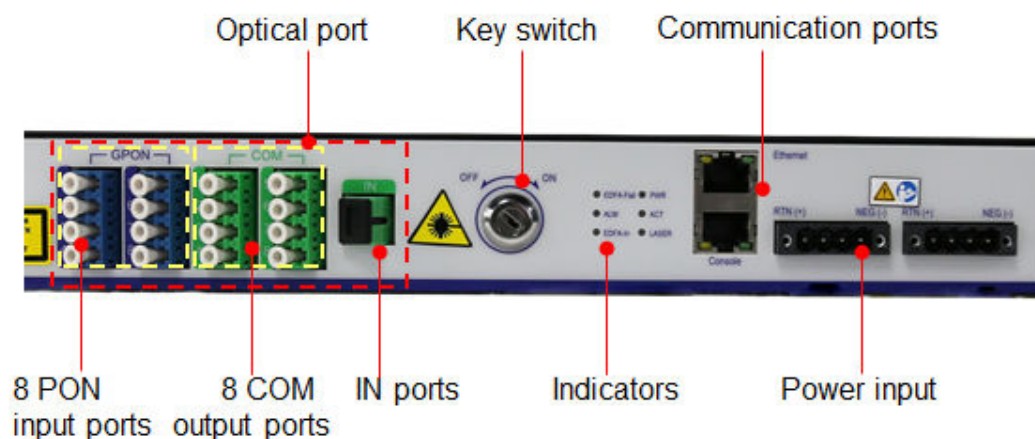

Table 3-1 Description of optical ports

Port	Description	Connector Type
PON	It leads in 8 channels of PON signals.	LC/UPC
COM	It outputs 8 channels of EDFA signals.	LC/APC
IN	It leads in CATV signals.	SC/APC

Table 3-2 Description of key switch(PUMP light switch)

Key Switch Status	Description
ON	Indicates that the EDFA is enabled.
OFF	Indicates that the EDFA is disabled.

⚠ CAUTION

When you turn on the PUMP laser lock, do not look into the COM ports without eye protection. Otherwise, the laser will injure your eyes.

Table 3-3 Description of indicator status

Indicator	Description
EDFA-Fail	<ul style="list-style-type: none"> ● Off: HFA is normal. ● Red: The output optical power of the EDFA is lower than the threshold for the output optical power; the temperature of the HFA exceeds the upper limit; the PUMP current of the HFA exceeds the upper limit; hardware is faulty.
ALM	<ul style="list-style-type: none"> ● Off: The fan status is normal. ● Red: Indicates that the fan temperature exceeds the threshold; the fan speed is abnormal; other hardware is faulty.
EDFA-In	<ul style="list-style-type: none"> ● Green: The EDFA receives CATV signals normally. ● Red: The device receives CATV signals abnormally; the fiber patch cord connector or the input port of the EDFA is not clean; hardware is faulty.

Indicator	Description
PWR	<ul style="list-style-type: none"> ● Green: The power module works normally. ● Off: The power module is faulty.
ACT	<ul style="list-style-type: none"> ● Blinking green: The device runs normally. ● Off: The service module is faulty.
LASER	<ul style="list-style-type: none"> ● Green: The PUMP of the HFA is turned on. ● Off: The PUMP of the HFA is turned off; hardware is faulty.

Figure 3-3 Control Module

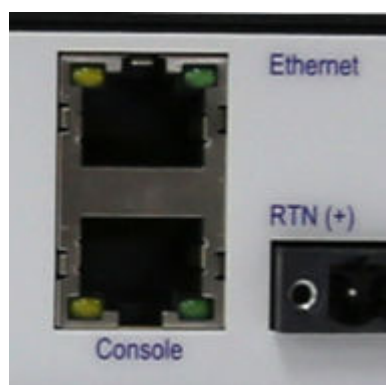

For details about the communication ports, see [Table 2-1](#).

The power module supports dual -48 V DC inputs. The left pin of the wiring terminal inputs 0 V , the right pin inputs -48 V , and the 2 pins in the middle are suspended.

Figure 3-4 Power Module



3.3 Fan Module

[Figure 3-5](#) shows the fan module. To remove the fan module, pull the clamp (as shown in the following figure) outwards. To install the fan module, push it forward.

Figure 3-5 Fan module



4 Technical Specifications

This topic describes the device specifications, environmental specifications, performance specifications, safety standards compliance, and electromagnetic compatibility (EMC) standards compliance of the EDFA.

Device Specifications

Table 4-1 Device specifications

Item	Specification
Dimensions (H x W x D; unit: mm)	43.6×442×240
Weight	4.9 kg
Number of signal input ports	CATV: 1 PON: 8
Number of signal output ports	8
Port connector type	CATV: SC/APC PON: LC/UPC COM: LC/APC
DC power voltage	Voltage range: -38.4 V to -72 V DC
Maximum power consumption	45 W
Flame-retardant rating	UL94V-0
RoHS	Compliant with European Union (EU) RoHS standards

Performance Specifications

Table 4-2 Performance specifications

Specifications		Value
Entire equipment	Wavelength of CATV	1545 nm to 1565 nm
	Input power cover range of CATV	-10 dBm@1550 nm to +10 dBm@1550 nm
	Constant output power control with output powers of CATV	≥ 19.5 dBm@1550 nm (typical output power: 20.0 dBm@1550 nm)
	Wavelength of PON	1260nm to 1360nm& 1480nm to 1500nm
	Insertion loss	PON to COM: ≤ 1.0 dB
	Return loss	≥50dB
	Output power uniformity (among output ports)	-0.5 dB to +0.5 dB
	Polarization-dependent gain	≤ 0.5 dB
	Noise figure	<5.5 dB@ 0dBm (CATV input)
	Output stability	+/-0.5 dB
	Life time	≥ 10 years
Signal multiplexing specifications	Pass band	1310 nm &1490 nm
	Reflection band	1550 nm
	Polarization mode dispersion	≤0.5 ps
	Isolation Pass	Pass band @1550nm: ≥ 40 dB Reflection band @1310&1490nm: ≥ 15 dB

Environmental Specifications

Table 4-3 Environmental Specifications

Item		Storage Environment	Operating Environment
Standards compliance		ETSI EN 300 019-2-1	ETSI EN 300 019-2-4
Climate	Atmospheric pressure	70 kPa to 106 kPa	-

Item		Storage Environment	Operating Environment
	Temperature	-40°C to +70°C	-5°C to +65°C
	Temperature change rate	≤1 °C/min	≤0.5°C/min
	Relative humidity	5%RH to 95%RH	5%RH to 95%RH
	Solar radiation	≤ 1120 W/m ²	-
	Heat radiation	≤600 W/m ²	-
	Altitude	-	≤ 4000 m
	Wind speed	-	≤ 5 m/s
<p>NOTE</p> <ul style="list-style-type: none"> ● The temperature and humidity are measured 1.5 m above the floor and 0.4 m from the front of the device. ● This product's operating temperature is -5°C to 65°C. The outdoor installation needs to use the heat exchanger cabinets, such as Huawei S200. ● The air density varies with the altitude, which affects the heat dissipation capability of devices. Therefore, the operating temperature of the device changes with the altitude. 			

Item	Storage Environment	Operating Environment
Water resistance requirements	<ul style="list-style-type: none"> ● When the device is stored on a customer site, it is stored indoors whenever possible. ● No water remains on the floor or wets the device package. ● The device is away from places where water leakage is possible, such as the places near the automatic fire-fighting facilities and heating facilities. ● If the device has to be stored outdoors, ensure that the following conditions are satisfied: <ul style="list-style-type: none"> - The package is intact. - Required rainproof measures are provided to prevent water from entering the package. - No water remains on the storage ground or wets the device package. - The package is not exposed to sunlight. 	-
Biological environment requirements	<ul style="list-style-type: none"> ● No fungus or mildew grows in the operating environment. ● The operating environment is free from rodents, such as mice. 	
Air cleanness requirements	<ul style="list-style-type: none"> ● The air is free of explosive, conductive, magnetic conductive, or corrosive dust. ● The density of mechanically active substances in the air complies with the requirements defined in Table 4-4. <p>The density of chemically active materials in the air complies with the requirements defined in Table 4-5.</p>	
Mechanical stress requirements	The mechanical stress complies with the requirements defined in Table 4-6 .	The mechanical stress complies with the requirements defined in Table 4-7 .

Table 4-4 Requirements on density of mechanically active substances in the air

Mechanically Active Substance	Required Density in the Storage Environment	Required Density in the Operating Environment
Suspended dust	≤ 5.00 mg/m ³	≤ 0.40 mg/m ³

Mechanically Active Substance	Required Density in the Storage Environment	Required Density in the Operating Environment
Deposited dust	$\leq 20.0 \text{ mg}/(\text{m}^2 \text{ h})$	$\leq 15.0 \text{ mg}/(\text{m}^2 \text{ h})$
Sand	$\leq 300 \text{ mg}/\text{m}^3$	$\leq 300 \text{ mg}/\text{m}^3$

Table 4-5 Requirements on density of chemically active substances in the air

Chemically Active Substance	Required Density in the Storage/ Operating Environment
SO ₂	$\leq 0.30 \text{ mg}/\text{m}^3$
H ₂ S	$\leq 0.10 \text{ mg}/\text{m}^3$
NO ₂	$\leq 0.50 \text{ mg}/\text{m}^3$
NH ₃	$\leq 1.00 \text{ mg}/\text{m}^3$
Cl ₂	$\leq 0.10 \text{ mg}/\text{m}^3$
HCl	$\leq 0.10 \text{ mg}/\text{m}^3$
HF	$\leq 0.01 \text{ mg}/\text{m}^3$
O ₃	$\leq 0.05 \text{ mg}/\text{m}^3$

Table 4-6 Mechanical stress requirements in the storage environment

Item	Subitem	Specifications (ETSI EN 300 019-1-1)		
Random vibration	Frequency range	5 Hz to 10 Hz	10 Hz to 50 Hz	50 Hz to 100 Hz
	Acceleration spectral density (ASD)	-	0.02 m ² /s ³	-
	dB/oct	+12	-	-12

Table 4-7 Mechanical stress requirements in the operating environment

Item	Subitem	Specifications (ETSI EN 300 019-1-1)		
Random vibration	Frequency range	5 Hz to 10 Hz	10 Hz to 50 Hz	50 Hz to 100 Hz
	ASD	-	0.02 m ² /s ³	-
	dB/oct	+5	-	-5

Item	Subitem	Specifications (ETSI EN 300 019-1-1)
Shock test	Shock response spectrum II	Half sine wave 150 m/s ² when an 11-ms shock test that includes 18 shocks and covers 6 directions (3 shocks per direction)

Safety Standards Compliance

This product complies with EN60950-1, IEC/EN60825-1/2 and IEC62368.

EMC Standards

Table 4-8 Mechanical stress requirements in the storage environment

Item	Standards Compliance
Overall radiated emission (RE)	EN55032/EN50083-2
Port electrostatic discharge (ESD)	IEC61000-4-2/EN50083-2
ESD of the signal port	IEC61000-4-2
Overall radiated susceptibility (RS)	IEC61000-4-3/EN50083-2
Conducted emission (CE) of the DC power port	EN55032
Electrical fast transient/burst (EFT/B) of the DC power port	IEC61000-4-4
Surge of the DC power port	IEC61000-4-5
Conducted susceptibility (CS) of the DC power port	IEC61000-4-6
DIP of the DC power port	IEC61000-4-29
DC power port	ETSI EN300 132-2
EFT/B of the signal port	IEC61000-4-4
Surge of the signal port	IEC61000-4-5
CS of the signal port	IEC61000-4-6

5 iManager U2000

This section describes the software that manages the EDFA, iManager U2000 network management system (NMS) (U2000 for short).

The U2000 provides powerful management functions at the NE layer and network layer. It is the major network management product and solution of Huawei.

The EDFA can be managed and configured through the U2000. It supports alarm query and other functions, as shown in the following figure. For detailed functions, see *EDFA0820-D V100R019C00 Software Operation and Configuration Guide 03*.

Figure 5-1 Device management interface

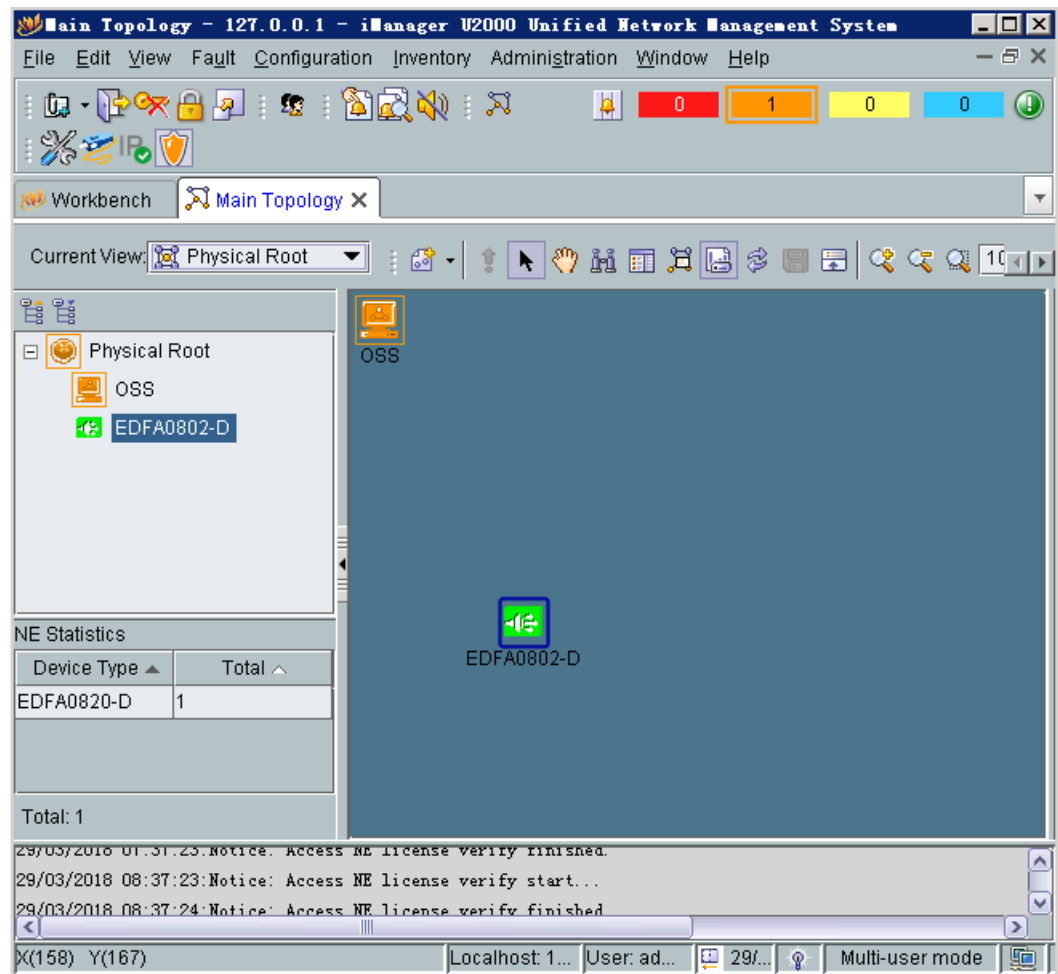

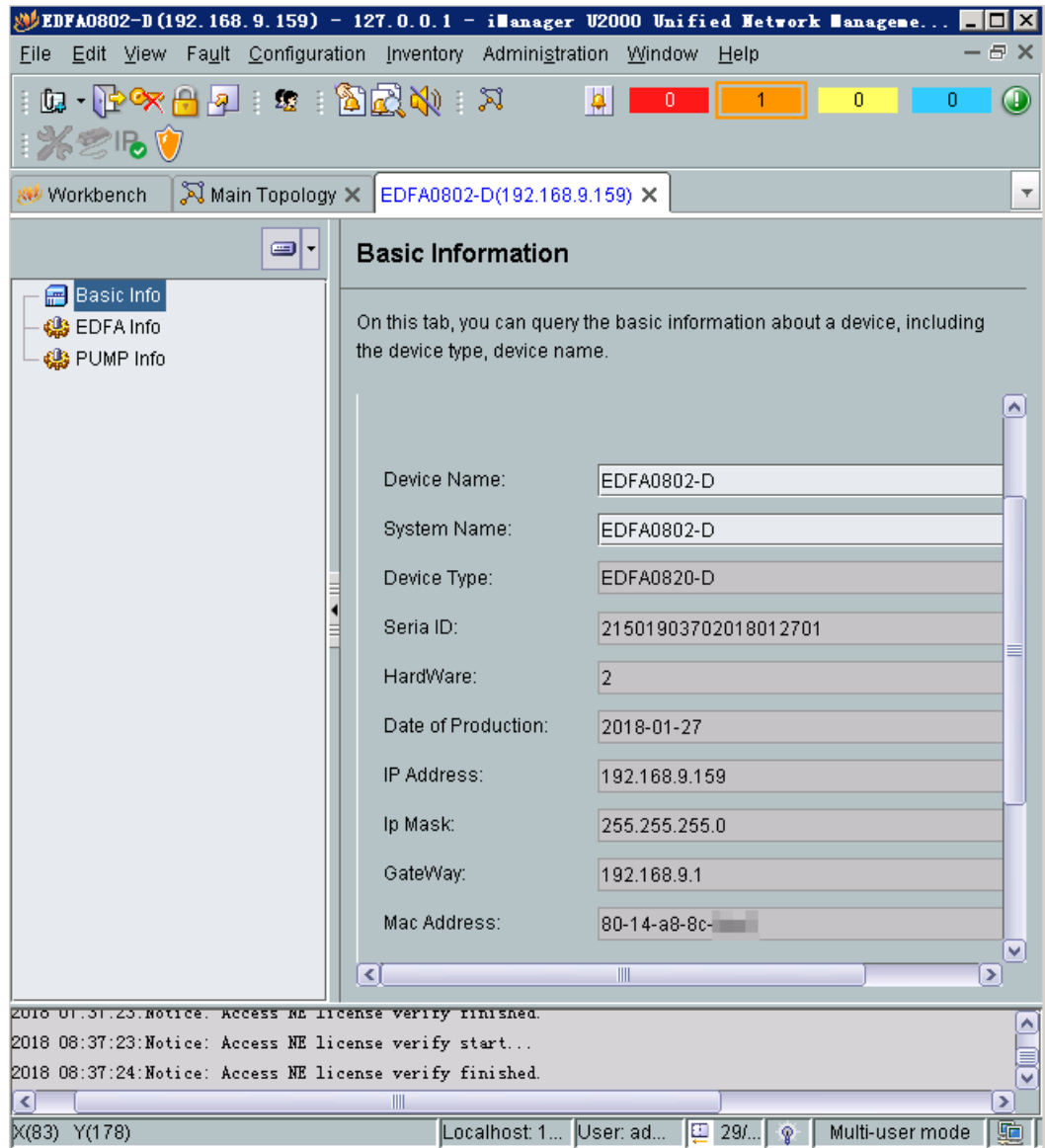
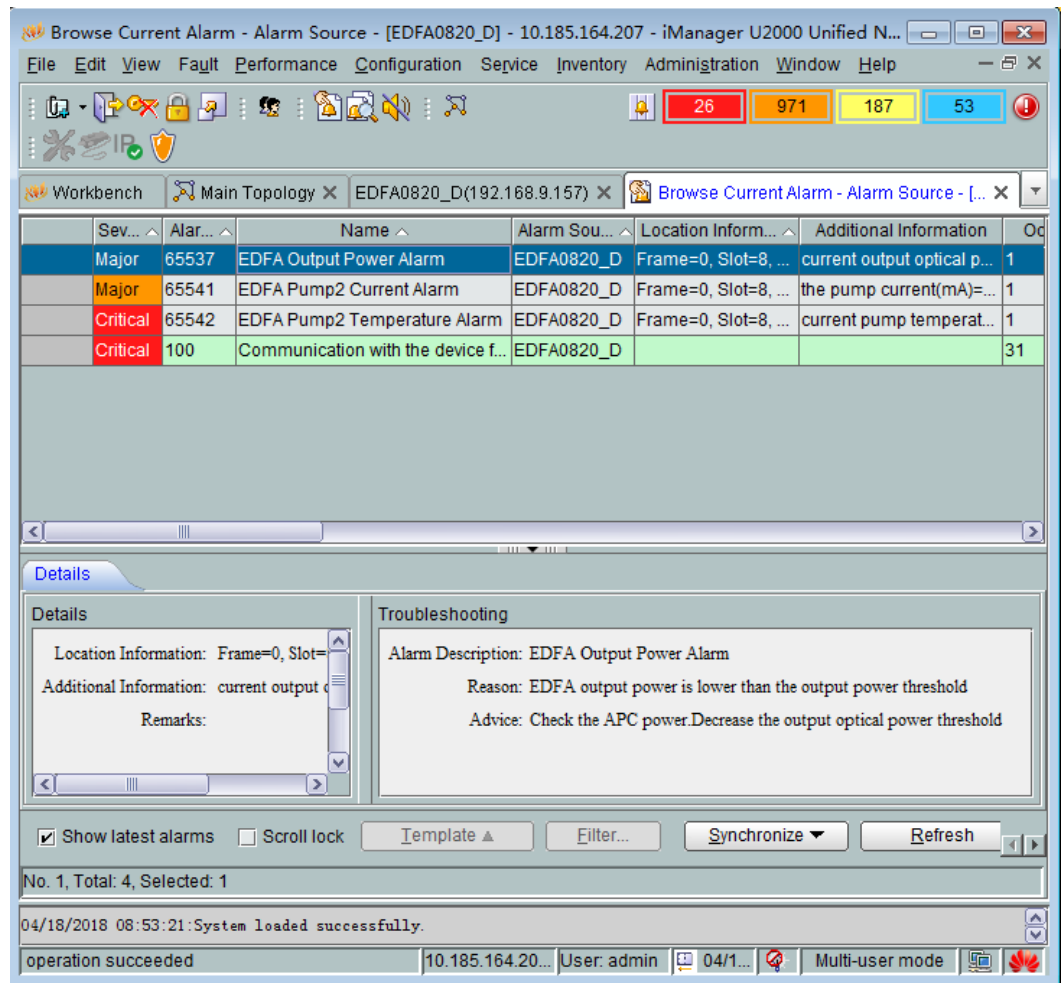

Figure 5-2 Alarm query interface



A Acronyms and Abbreviations

This topic describes acronyms or abbreviations and their full names.

Acronym/ Abbreviation	Full Name
API	Application Programming Interface
CATV	Cable TeleVision
CM	Cable Modem
CO	Central Office
DC	Direct Current
EDFA	Erbium-doped Optical Fiber Amplifier
EMC	ElectroMagnetic Compatibility
EMU	Environment Monitoring Unit
FTTB	Fiber To The Building
FTTH	Fiber To The Home
GPON	Gigabit-capable Passive Optical Network
IPTV	Internet Protocol TeleVision
MSO	Multiple System Operator
OA	Optical Amplifier
ODN	Optical Distribution Network
ONT	Optical Network Terminal
OSW	Optical Switch
PON	Passive Optical Network
PWR	Power Cable
QAM	Quadrature Amplitude Modulation

Acronym / Abbreviation	Full Name
SNMP	Simple Network Management Protocol
TCP/IP	Transmission Control Protocol/Internet Protocol
WDM	Wavelength Division Multiplexing