

# How to Choose a Modular UPS

## White Paper

Huawei Technologies Co., Ltd.



**Copyright © Huawei Technologies Co., Ltd. 2016. All rights reserved.**

No part of this document may be reproduced or transmitted in any form or by any means without prior written consent of Huawei Technologies Co., Ltd.

## **Trademarks and Permissions**



and other Huawei trademarks are trademarks of Huawei Technologies Co., Ltd.

All other trademarks and trade names mentioned in this document are the property of their respective holders.

## **Notice**

The purchased products, services and features are stipulated by the contract made between Huawei and the customer. All or part of the products, services and features described in this document may not be within the purchase scope or the usage scope. Unless otherwise specified in the contract, all statements, information, and recommendations in this document are provided "AS IS" without warranties, guarantees or representations of any kind, either express or implied.

The information in this document is subject to change without notice. Every effort has been made in the preparation of this document to ensure accuracy of the contents, but all statements, information, and recommendations in this document do not constitute a warranty of any kind, express or implied.

## **Huawei Technologies Co., Ltd.**

Address: Huawei Industrial Base  
Bantian, Longgang  
Shenzhen 518129  
People's Republic of China

Website: <http://www.huawei.com>

Email: [support@huawei.com](mailto:support@huawei.com)

## Preface

In recent years, with the rapid development of big data and cloud computing, traditional data centers face fast transformation. As a key part of the power supply and distribution system of a data center, the uninterruptible power supply (UPS) also changes. As the modular UPS technology is gradually mature, more and more users have used or are considering using modular UPSs to construct new data centers. To meet users' requirements on environment protection, high efficiency, easy capacity expansion, and easy maintenance, vendors successively launch the large-capacity modular UPS. The market position of the traditional tower-mounted UPS suffers the challenge.

Facing the large amount of promotion information about the modular UPS from various UPS vendors and different technical opinions, many UPS users are confused about how to choose a proper modular UPS and what is a real modular UPS. This document answers these questions.

## 1. Why Is the Modular UPS Used?

Actually, many users may ask this question. In the industry, people generally think that compared with the tower-mounted UPS, the modular UPS has the irreplaceable advantages in terms of installation, maintenance, and subsequent capacity expansion. However, the performance of environment protection, high efficiency, and energy saving depends on the internal circuits and technologies used by the UPS, for example, whether the insulated gate bipolar transistor (IGBT) rectifier or the silicon controlled rectifier (SCR) is used, and whether the output isolation transformer is used, and has little relationship with the external structure of the UPS. What needs attention is that compared with early-stage transformer-based UPSs, as adopting transformer-less technologies including transformer-less design and IGBT rectification, most current modular UPSs have obvious advantages in harmonic reduction and efficiency promotion. At the same time, relative to the traditional transformer-based UPS, the transformer-less design and IGBT rectification are also the technical highlight of the transformer-less tower-mounted UPS.

### 1.1 Advantages of the Modular UPS

Generally, the modular UPS publicized by vendors has the following advantages:

- **Good usability, easy installation and capacity expansion**
- **Strong availability, easy maintenance**
- **Capacity expansion on demand, reducing the initial investment**
- **Module hibernation, improving the efficiency and saving the operation cost**
- **Intelligent network management system, providing the strong monitoring function**



As members in the transformer-less UPS family, the transformer-less modular UPS and the transformer-less tower-mounted UPS have the following common advantages:

**Environment protection, harmonic pollution reduced:** With the power factor correction (PFC) technology controlled by the digital signal processor (DSP), the transformer-less UPS abandons the SCR rectification technology; therefore, the input harmonic current is further decreased, and the pollution to the grid is reduced. In addition, the input PFC is close to 1 (mostly reaches 0.99, almost pure resistant load).

**High efficiency and energy saving, electricity cost reduced:** The cancelation of the transformer and the application of power components with low conduction loss, soft switch technology, and new topology further improve the efficiency of the transformer-less UPS.

**Small size and light weight, easy to transport and install:** As the output isolation transformer is canceled, the volume of the transformer-less UPS is further reduced and the weight is much lighter. The transformer-less is easier to transport and install than the transformer-based UPS.

**High power density, floor area reduced:** The application of the high-power components, DSP digital control system, more advanced topology, reduction of loss, and widely application of key technologies such as thermal simulation enable the transformer-less UPS to obtain higher output power in the same volume. In addition, as the single rack capacity is greatly improved and the area of the data center is limited, more and more data centers prefer to choose transformer-less UPSs.

No matter in the aspect of development trend, purchase cost, or post-sales maintenance, except several scenarios, all indicators of the transformer-less UPS are superior to those of the traditional transformer-based UPS. The trend "transformer-less UPS replacing transformer-based UPS" has been widely recognized in the industry. Currently, vendors reduce or stop the research on the transformer-based UPS. According to the statistics in recent years, most of newly established data centers outside China have taken the transformer-less UPS as the first choice.

**Table 1** Differences among the transformer-based UPS, transformer-less tower-mounted UPS, and transformer-less modular UPS

	<b>Transformer-based UPS</b>	<b>Transformer-less UPS</b>		<b>Conclusion</b>
<b>Structure</b>	Tower-mounted UPS	Tower-mounted UPS	Modular UPS	
<b>Volume</b>	Large	Medium	Medium	The volume of a transformer-less UPS is smaller.
<b>Efficiency</b>	Relative low	High	High	The transformer-less UPS is more energy efficient.
<b>Harmonic interference</b>	High	Low	Low	The transformer-less UPS is more environment-friendly.
<b>Usability</b>	Poor	General	Good	The modular UPS is more convenient to use.
<b>Component failure rate</b>	Low	Low	Relative low	The component failure rate of the transformer-based UPS is lower.
<b>Maintenance time</b>	Long	Relative long	Short	The maintenance time of the modular UPS is short.
<b>System availability</b>	Low	Relative high	High	The availability of the modular UPS is better.
<b>Load impact resistance capacity</b>	High	Relative high	Relative high	The isolation transformer of a transformer-based UPS has a certain buffer capability (for the functions of the isolation transformer, see the fifth question in 1.2 FAQs).

## 1.2 FAQs

### a). The transformer-based UPS consists of fewer components. Is the transformer-based UPS more reliable than the modular UPS?

The transformer-based UPS adopts the SCR to implement rectification (6 pulses or 12 pulses). The performance of electric indicators such as the output PF and harmonic current is poor. However, the circuit structure of the transformer-based UPS is simple and the technology is mature after the development of more than thirty years. In addition, as the useful life of the UPS is long, some users are used to choosing the transformer-based UPS they have ever used when the existing UPS needs to be replaced. It has been more than a decade since the transformer-less UPS was launched. The technology of vendors is very mature. The reliability of the circuit structure of the transformer-less UPS nearly has no difference with that of the transformer-based UPS.

As a new member of the transformer-less UPS family, the modular UPS was launched a little later. However, as the modular UPS features easy maintenance and rapid development, an increasing number of vendors launched their own modular UPSs.

Figure 1 6-pulse and 12-pulse circuits and current waveforms

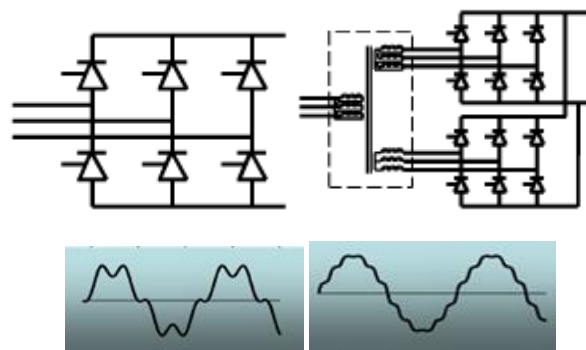

As the early-stage modular UPS was not mature in technologies, especially the design of the control logic, mode conversion, faulty module automatic quit of modular UPSs from some vendors had defects, some users considered that the reliability of the modular UPS is not high. Actually, through years of development, especially the application of various new components and technologies, modular UPSs from mainstream vendors have been mature in technology and are reliable in quality. More and more transformer-less tower-mounted UPSs adopt the "quasi-modular" technology in the mechanical structure to facilitate subsequent maintenance.

The form of products is not the standard to distinguish the reliability. The product reliability depends on the attitude and specificity of the vendor for pursuing the reliability, for example, whether the system solution has sufficient redundancy, whether the application circuit is mature, whether components are sufficient, whether the production technology and manufacturing system are complete, and whether the pre-delivery inspection of products is comprehensive. The reliability of the modular UPS is not lower than the transformer-based UPS. As using the modular structure, the modular UPS is easier to maintain and more available, and

is more and more popular in the market. Therefore, the product reliability mainly depends on the strength of the vendor.

**b). How is the current equalization capability of the modular UPS?**

The current equalization of the modular UPS has no essential difference with other UPSs. The performance indicators shall comply with the international standards and industry standards or specifications. According to the UPS industry standards YDT-2165 issued by Ministry of Posts and Telecommunications of Republic of China, the current imbalance rate is 5% or less when the output power exceeds 4 kVA and is 10% or less when the output power is below 4 kVA.

**c). Do the modular UPS and the tower-mounted UPS parallel system have the same reliability?**

A lot of users consider the modular UPS as a simple parallel system of traditional tower-mounted UPSs. However, they always ignore the differences in the operating principle. For example, many users think that when a UPS in the parallel system is faulty, other UPSs still operate, just like the modular UPS. Actually, in the parallel system, when a UPS is faulty (the system switch to the bypass mode), to prevent short circuit due to output differences of different UPSs (in the normal mode, the rated voltage is output; in the bypass mode, the mains power supply voltage is output), the system will switch all parallel UPSs to the bypass mode. In this case, the power failure may occur. However, the modular UPS does not have this risk. When a power module is faulty, the power module automatically quit the system, and other power modules still work properly. Therefore, the security of the modular UPS is much higher.

Figure 2 UPS parallel system in the bypass mode

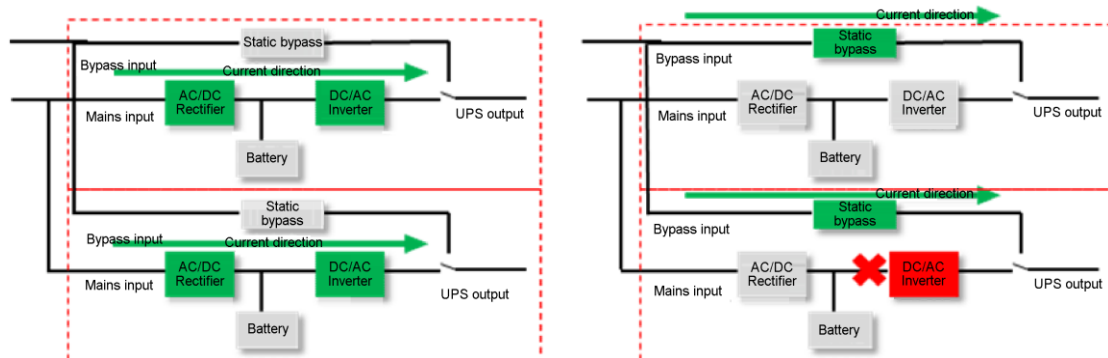

**d). Is the modular UPS reliable? What are common faults?**

Most faults of the UPS occur in the power conversion part (rectifier and inverter current). According to the design concept of the modular UPS, the modular UPS adopts the power module redundancy technology. Therefore, the reliability of the power conversion part is greatly improved. As other parts such as the bypass, input and output power distribution, and monitoring are in simple circuit structures and the number of related components is small, their reliability is also high. Therefore, the overall availability of the modular UPS is higher than that of the tower-mounted UPS. According to the feedback of some users, the following

faults generally occur on the modular UPS:  
 When being faulty, a power module cannot quit the system.  
 When the active control module is faulty, the standby control module cannot take over tasks in a quick manner.  
 Communication failures between modules lead to the system failure.  
 The interference of various communication cables triggers false alarms  
 Current equalization cannot be implemented between power modules.

**e). Is the modular UPS without an isolation transformer reliable?**

Due to the limitations of the circuit topology and early-stage power components, a transformer needs to be embedded in the output end of the traditional transformer-based UPS to reach the working voltage required by the load. In addition, the isolation transformer reduces the impact of the load on the UPS to a certain extent. In another word, the isolation transformer functions as an isolation layer of the system. In the current modular UPS, fuses are configured at the input and output of power modules for protection, and the relay is configured at the output for isolation. The relay has the same function of the isolation transformer of the transformer-based UPS. When a power module is faulty, the DSP responds quickly and isolates the faulty module from the system. Therefore, the reliability of the modular UPS without an isolation transformer is not decreased. On the contrary, the traditional frequency-power UPS, which has a large and heavy isolation transformer, becomes increasingly difficult to meet the requirements of the new data centers on high density, high efficiency, and flexible installation. The loss of the isolation transformer not only lowers the system efficiency but also generates large amounts of heat that may shorten the useful life of internal components of the UPS.

Currently, mainstream UPS vendors promote the transformer-less UPS without the output isolation transformer as the mainstay product. Except in some special scenarios, the isolation transformer is not needed.

**2. Comparison of the Modular UPS and the Tower-mounted UPS**

Compared with the traditional tower-mounted UPS, the modular UPS has many advantages. However, in different regions and industries, disputes still exist due to different cognition. This document only compares related features, as listed in Table 2. (As different vendors have different prices, the comparison of investment is only for reference.)

**Table 2** Comparison of the reliability of the tower-mounted UPS and the modular UPS

	<b>Detail</b>	<b>Tower-mounted UPS</b>	<b>Modular UPS</b>
<b>Reliability of the parallel networking</b>	Hardware design	Power controller integrated with the parallel control	Power controller+Parallel controller



	Logic design	Master/Slave competition redundancy with a complex logic	Master/Slave competition redundancy or centralized control
	Communication	Single control area network (CAN) or double CANs	Single CAN or double CANs
	<b>Reliability evaluation</b>	****	****
<b>Reliability of the power unit</b>	Voltage loop	Independent control for modules	Independent control for modules
	Current loop	Analog control/digital control	Full digital control
	Component reliability	Less redundancy design	Partial redundancy design
	<b>Reliability evaluation</b>	***	****
<b>Reliability of the bypass unit</b>	Parallel bypass	Distributed bypass	Parallel system within the rack: centralized bypass Parallel system between racks: distributed bypass
	<b>Reliability evaluation</b>	****	****
<b>Impact of power unit failures</b>	Scope	When a unit is faulty, the entire system is affected and the power loss is large.	When a module is faulty, the entire system is not affected, and the power loss is small.
	<b>Reliability evaluation</b>	****	*****

<b>Overall reliability evaluation</b>	****	****
---------------------------------------	------	------

**Table 3** Comparison of usability of the tower-mounted UPS and the modular UPS

	<b>Detail</b>	<b>Tower-mounted UPS</b>	<b>Modular UPS</b>
<b>Installation and transportation</b>	Volume and weight	Large	Small
	Transportation	The infrastructure of the data center needs to be changed in some situations, and some devices can be transported by cabinet.	Devices can be transported by cabinet or module.
	Capacity expansion	The UPS is basically removed and reconstructed.	Easy capacity expansion, staged investment
	<b>Usability evaluation</b>	****	*****
<b>Usability</b>	Monitoring	Basic monitoring capability	Basic monitoring capability
	Battery	Rarely sharable	Partially sharable
	<b>Usability evaluation</b>	****	****
<b>Maintenance</b>	Maintenance	<p>The cables and internal structure need to be removed.</p> <p>The maintenance duration is long.</p> <p>The modules of a quasi-modular UPS can be removed</p>	Power modules can be hot-swapped.

		separately to maintain.	
	Usability evaluation	***	*****
Overall usability evaluation		***	****

**Table 4** Comparison of investment of the tower-mounted UPS and the modular UPS

	Detail	Tower-mounted UPS	Modular UPS
Device	UPS host	The entire system is paralleled. The redundant power is high, and the cost is proper.	Modules are paralleled. The redundant power is low, and the cost is proper.
	Battery	Rarely sharable, high configuration	Partially sharable, flexible configuration, low cost
	Investment evaluation	****	*****
Installation and transportation	Volume and weight	Large; the land rent and the cost of bearing parts are high.	Small
	Transportation	The infrastructure of the data center needs to be changed in some situations. Therefore, the cost is high.	Devices can be transported by cabinet or module.
	Capacity expansion	The UPS is basically removed and reconstructed. Therefore, the cost is high.	Easy capacity expansion, staged investment

	Investment evaluation	****	*****
Operation	Efficiency	85% to 94%	94% to 96%
	Investment evaluation	***	****
Maintenance	Maintenance	<p>The cables and internal structure need to be removed.</p> <p>The maintenance cost is high.</p> <p>The modules of a quasi-modular UPS can be removed separately to maintain.</p> <p>The maintenance cost is proper.</p>	<p>Power modules can be hot-swapped. Therefore, the maintenance cost is low.</p>
	Investment evaluation	***	****
Overall investment evaluation		***	****

### 3. How to Choose a Proper Modular UPS?

Vendors declare that their products are true modular UPSs. What UPSs can be called modular UPS? What parameters and features should users pay attention to? What indicators must meet requirements? We think that users shall focus on the following items:

- External features
- Electrical properties
- System design
- Usability design
- Manufacturing process
- Post-sales service

#### 3.1 Choosing a Modular UPS According to External Features (such as the volume, weight, cabling mode, and cabinet combination mode)

**Volume:** With the development of big data and cloud computing and considering the large scale data computing and energy consumption reduction, data centers develop toward the centralized mode. As a result, the UPS is required to be in smaller size, have a higher power density, and support a more flexible

installation. The UPS with a small floor area and high power density per cabinet will save more rental expenses of the data center for users. Currently, the single power cabinet of common modular UPSs can support a capacity of more than 200 kVA (about 0.5–0.7 m<sup>2</sup> excluding the switchgear).

**System capacity:** The system capacity is related to the module size and the number of modules that can be paralleled. In theory, a maximum of 49 nodes can be connected on a CAN bus. (Note: For details about this theory, see the *Huawei White Paper-Discussion on the Number of Parallel Modular UPSs*.) However, the more parallel modules, the more complex logic. Therefore, you are advised to control the number of modules in a UPS system within 20.

**Single module capacity/weight:** Currently, vendors provide power modules with the capacity ranging from 10 kVA to 50 kVA. Different power module can be used in the same UPS system of some vendors. If the module capacity is small, more power modules are used in a system. The system reliability is decreased (the control logic is complex, the signal interference is increased, and the single module failure may lead to the entire system failure). However, if the module capacity is large but the system capacity is low, the redundancy may be insufficient or capacity waste may occur. If the system capacity is large, you can select large-capacity power modules. **The module with the capacity ranging from 20 kVA to 50 kVA is recommended.**

To facilitate using, a power module should not be too heavy. Generally, a power module with the weight within 40 kg is recommended. In this case, it requires only two people to install and maintain the power module. If the power module is too heavy and needs to be installed on the top of the cabinet, you need to use the mechanical equipment to help installation. The installation complexity and cost are increased.

**Installation mode:** Generally the UPS input and output cables are cabled underfloor or overhead (respectively for the ESD floor and lifting cable tray). The actual operating environment of users is changeable. To lower the construction difficulty, the modular UPS is required to support two cabling modes.

In some data centers with limited space or modular data centers, the UPS may be installed against the wall or other cabinets. Therefore, the modular UPS shall have the complete front-access design for installation and maintenance. (Some vendors may ensure front access but cannot ensure front installation of all cables. Users can make requests based on site requirements.)

**Cabinet combination mode:** The modular UPS system includes the power cabinet and distribution cabinet (bypass cabinet in some scenarios). Some vendors may sell the power cabinet and distribution cabinet as a whole, and the two cabinets cannot be configured separately (the two cabinets may be connected using the copper bar or the distribution cabinet includes the monitoring and bypass modules). In addition, other vendors may provide unified power cabinets. A unified power cabinet integrates the functions of monitoring, bypass, and power distribution, which can be sold as an independent UPS. Users can choose the UPS based on site requirements. Generally, if the data center has been equipped with a distribution cabinet, you are advised to choose the independently sold UPS power cabinet to save expenses.

What needs attention is that the large-capacity modular UPS of some vendors is not a UPS system but a parallel system of two UPSs. The parallel system is the same as the tower-mounted UPS parallel system, which includes two independent monitoring and bypass systems. Without the system redundancy, the parallel system has risks in some scenarios (such as the inverter overload and asynchronous UPSs during bypass switch).

*Example: The 240 kVA modular UPS system of a vendor actually consists of two 120 kVA UPS systems connected by parallel connection cables (each UPS system contains six 20 kVA modules). In structure, the 240 kVA modular UPS system keeps all hardware and software structures of the single UPS system. The two 120 kVA UPS systems keep their own monitoring systems, bypass control systems, and software control structures, respectively. They are only connected by parallel connection cables. The modular UPS system in this mode cannot function as a 240 kVA system whether in structure or software control, and can only function as a single-rack 120 kVA UPS system.*

**System parallel connection capability:** Similar to the tower-mounted UPS, the number of UPSs to be paralleled of the modular UPS is also an important factor of capacity. When users require capacity expansion but the capacity of the single system modular UPS is insufficient, the vendors shall be required to provide UPSs with the parallel connection capability. To improve the reliability of the parallel system, the parallel UPSs shall be connected using the ring parallel connection cables. In this mode, the impact of single point failures on the system can be prevented and the failures will not be expanded. Whether the UPS has the parallel connection capability is a factor to evaluate a vendor's design capability. You can configure the modular UPS parallel system according to the configurations of the tower-mounted UPS parallel system.

Figure 3 Ring parallel connection cables prevent single point failures of communication

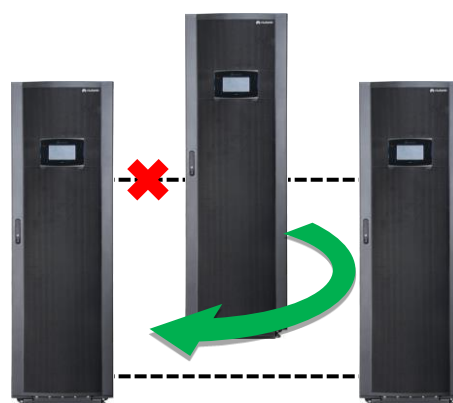

### 3.2 Choosing a Modular UPS According to the Electrical Properties (such as the efficiency, harmonic, current equalization rate, PF, and module hibernation function)

**Efficiency:** As described in the preceding chapter, when choosing a UPS, you need to consider not only the maximum efficiency but also the system efficiency during low-load operation. If the modular UPS has the automatic hibernation function, the system efficiency is improved during low-load operation. The system efficiency during low-load operation is also a factor for evaluating the technical capability of a vendor. Currently, the mainstream UPS vendors provide medium- and large-capacity UPSs with the system efficiency higher than 95%. The higher the system efficiency is, the better the UPS is.

Some UPSs support the energy-saving mode. These UPSs run in the bypass mode when the grid quality is good, and the system efficiency reaches 99%. However, the bypass mode depends on the quality of the local grid. The system must be able to automatically switch to the normal mode when the grid quality does not meet the requirement. If the vendor declares that their products provide this function, the vendor shall provide the switching duration. Generally, the switching duration is within 5 ms, which ensures the load has no interruption. In regions where the grid quality is poor or when the UPS uses the single input load power supply, do not use the bypass mode.

Figure 4 Actual efficiency and maximum efficiency of the UPS system

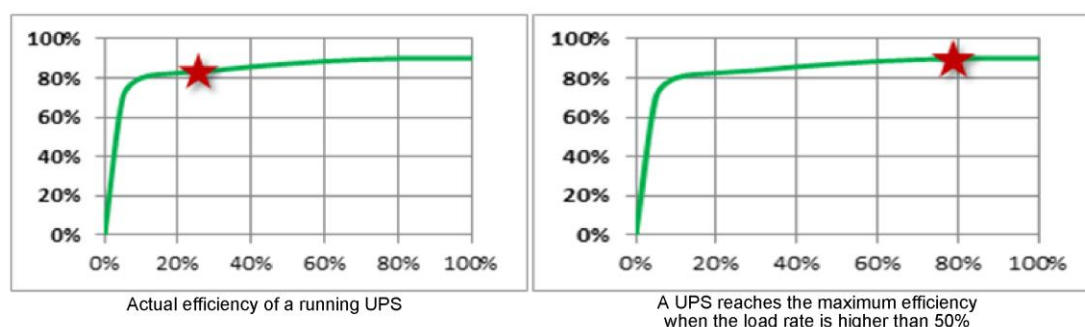

**Harmonic:** As the transformer-less UPS uses the IGBT rectifier and PFC technology, the input current harmonic (THDi) is much lower than that of the traditional transformer-based UPS. Modular UPSs of most vendors can ensure that the input current harmonic is equal to or lower than 3%. However, the input current harmonic of traditional transformer-based UPSs is higher than 10%.

**Three-phase load imbalance:** Products provide by vendors shall be equal to or lower than 3% as required in 5.3 of the *Technical Specification of Modular Uninterruptible Power Systems for Telecommunications* (YD/T 2165-2010).

**Current equalization rate of modules:** As multiple power modules are connected in parallel inside the modular UPS to output power, to ensure that each module can output consistent power, the UPS shall be equal to or lower than 5% as required in 5.3 of the *Technical Specification of Modular Uninterruptible Power Systems for Telecommunications* (YD/T 2165-2010).

**Input/output PF:** Generally, the PF of the transformer-less UPS adopting the PFC technology is higher than 0.99. The higher the PF is, the higher the proportion of the useful electric energy that the grid inputs to the UPS is and the lower the pollution of the UPS to the grid is. The PF indicates the actual power ( $kW = kVA \times$

Output PF) that the UPS can output. The output PF of the UPS is also the output PF of the load. Currently, the output PF of the IT load is higher than 0.9. Therefore, the output PF of the modular UPS shall be higher than 0.9 to meet the requirement of the current IT load. The higher the PF is, the wider the range of the load that the UPS output adapts to is and the stronger the loading capability of the UPS is.

**Hibernation function/energy-saving mode of modules:** As described in the preceding chapter, the hibernation function of power modules is a special function of the modular UPS, which improves the overall efficiency of the system and reduces the loss of the UPS. Therefore, the modular UPS should be configured with the intelligent hibernation function. The system determines whether to enable or disable power modules according to the actual load.

Figure 5 Hibernation function of power modules of the modular UPS

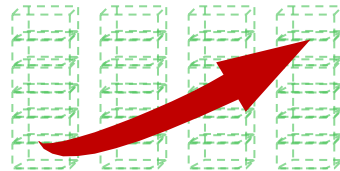

The number of working modules depends on the actual load

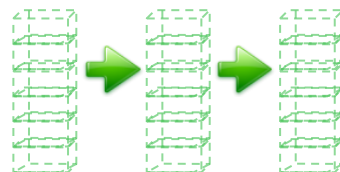

Different modules work alternately in a specified sequence and at a specified interval

In other regions where the grid quality is good, users require the UPS to support the energy-saving mode (in which the power is supplied through bypass and the system can switch to the inverter mode in a quick manner when the mains power supply state is poor). Therefore, the modular UPS shall support the energy-saving mode.

### 3.3 Choosing a Modular UPS According to the System Design (such as the module control mode and bypass control mode)

**Power module control mode:** Power modules in the modular UPS system are managed in a specified control mode to implement unified operation. Currently, the control mode of power modules is classified into the centralized control logic mode and distributed control logic mode. This document simply describes different control modes. Different control modes represent different technical opinions.

#### (1) Centralized control logic mode



The centralized control logic requires an independent centralized detection and control module unit (control module) to detect the frequency and phase of the mains power supply and send synchronizing pulses to each UPS module. When no mains power is supplied, the crystal oscillator generates synchronizing pulses and the phase-locked loop (PLL) of each UPS module is used to ensure synchronization of output voltage between units. The control module also detects the total current, calculates the current equalization reference value for each UPS through dividing the total current by the number of parallel UPS modules, and compares the value with the current of each module to calculate the deviation value and adjust the output current for each module in order to realize current equalization.

**Advantage:** The centralized control logic mode adopts an independent centralized control unit with clear control logic hierarchies. No competitive relationship exists between power modules. The software logic reliability is high.

**Disadvantage:** If the control unit is faulty, the single point failure may be expanded. (Note: The backup control unit can prevent single point failures.)

## (2) Distributed control logic mode

In the distributed control logic mode, the parallel control unit is installed on each module and a UPS power module is selected as the active control module according to a specified rule (generally the module sorting). Other modules function as standby control modules. When a power module in the UPS system is faulty, other modules still run. When the active control module is faulty, another power module takes over the tasks and functions as the active control module to ensure proper running of the system.

**Advantage:** The distributed control logic mode does not need an independent control module. Therefore, no single point failure occurs.

**Disadvantage:** The active control module not only processes its own signals but also coordinates signals between modules. Therefore, the control logic is complex, and the software logic reliability is not high. When the active control module is faulty, one of the remaining modules is automatically functions as the active control module. In this process, system failures may occur due the failure of competition.

Power module control modes vary according to vendors but have no significant difference in quality. To improve the reliability, the communication buses between modules shall adopt the ring structure or support the backup mode to prevent the communication failure due to single bus failure and even system failure.

**Bypass module control mode:** Currently, the large-capacity modular UPS system supports two bypass control technologies:

1. System centralized bypass control mode (a UPS system has only one bypass system).
2. System distributed bypass control mode (each power module in a UPS system has a bypass system).

Components used for bypass control can be classified into pure semiconductor devices and comprehensive devices (semiconductor devices and mechanical

devices). The centralized bypass control system features strong overload capability and high reliability, while the distributed bypass control system has the advantages of high capacity expandability. However, the distributed bypass control system may have certain reliability risks.

**Figure 6** Distributed bypass and centralized bypass

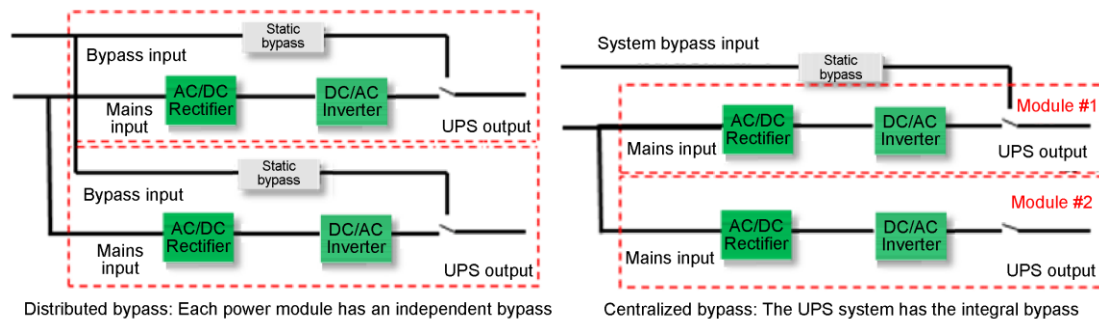

In the distributed bypass mode, components are deployed in distributed mode. Therefore, the distributed bypass mode seems to be similar to the redundancy design in which a bypass is faulty, other bypasses still work. Actually, the distribution is essentially different from redundancy. As bypass components are deployed in distributed mode, the capacity of each component is only  $1/N$  of the total system bypass capacity. In addition, the problem of current imbalance due to the component consistency reduces the capability of the static bypasses in withstanding the impact of transient current and reduces the system reliability. However, the easy capacity expansion of the modular UPS greatly reduces the redundancy capacity of the system in general situations. In theory, the actual load ratio of the system will be higher than 70% of the rated capacity. In the distributed bypass control mode, the total bypass capacity of the system is the sum of branch bypasses of all modules. The bypass capacity of the modular UPS system is actually more close to the rated capacity. Once the inverter is overloaded (the overload may occur during UPS start-up), the UPS is switched to the bypass output mode. If the bypass capacity is insufficient to bear the load, the output power failure may occur or event UPS components may be damaged. When a power module is faulty, the system will lose the branch bypass capacity provided by this power module, and the bypass overload risk will be higher. When the system is being switched to the bypass mode, all power modules must complete switching at the same time. Otherwise, the system failures may occur because some power modules are not switched in real time.

As the distributed bypass control mode has many disadvantages, users are advised to select the system centralized bypass control mode (the total bypass capacity of the system is fixed and does not change if a power module is damaged) and specify the total bypass capacity required by the system during initial planning.

### 3.4 Choosing a Modular UPS According to the Usability Design (such as easy operation, easy maintenance, and supporting hot swap and monitoring screen)

**Hot swap function:** According to the definition in the *Technical Specification of Modular Uninterruptible Power Systems for Telecommunications* (YD/T 2165-2010), the modular UPS consists of the input power distribution part, output power distribution part, power modules, and monitoring modules.

Modules have the following properties:

- A. Independent framework in machinery
- B. Complete and independent functions
- C. Coordination between modules

**Power modules:** Power modules include the rectifiers, inverters, charger (optional), PFC unit, and related control circuits. Power modules are main modules of the UPS system. In normal mode, the UPS system has the hot swap and parallel connection redundancy functions.

**Monitoring module:** The monitoring module monitors the UPS working state in real time, collects and stores the UPS operation parameters, stores fault records, and diagnoses faults. The monitoring module shall have the hot swap function.

According to the preceding information, except power modules, the monitoring module also needs to support hot swap. Then, the system can switch quickly when the monitoring module is faulty, and the hot swap process of the monitoring module shall not affect the normal operation of the system.

Except the monitoring module, to further improve the maintainability of the system, vendors shall be required to provide hot-swapped bypass modules. Especially the modular UPS in the centralized bypass control mode, due to its unique bypass system, bypass modules of the modular UPS in the centralized bypass control mode shall support hot swap. When a bypass module is removed, the system operation is not affected (UPSs of some vendors support bypass module replacement only when being switched to the maintenance bypass).

**No need to operate dual in-line package switches (DIP switches):** Users need to adjust DIP switches (generally, set addresses for power modules) when installing UPSs of some vendors. If users are not familiar with the configuration, it is easy to make mistakes. Therefore, the modular UPS must provide the function of automatically allocating addresses to power modules. Users do not need to set addresses manually.

**Unified monitoring:** Currently, the modular UPS monitoring system supports two control modes:

#### **(1) Centralized unified control mode**

The centralized unified control mode indicates that only a monitoring system exists in the system to monitor and manage all working conditions in a centralized mode.

#### **(2) Single-rack independent control mode**

The single-rack independent control mode indicates that an independent monitoring system is configured for each rack in the system. The working conditions and state of the system are affected by the monitoring system of each independent rack. System parameters can be adjusted manually on each rack

and then racks are connected using parallel connection communication cables to compose a large system. The control logic is complex.

As a whole system, the modular UPS shall have an independent monitoring system just like the tower-mounted UPS. Users can set parameters, view the state, and query alarms on the monitoring screen. It is unnecessary to configure the power modules or internal racks separately. The state of all UPS power modules can be displayed on the monitoring screen. Modular UPSs of some vendors may have multiple operation screens (even each power module has an operation screen). Users need to set parameters on each screen, which is inconvenient. **Therefore, the modular UPS shall adopt the centralized unified control mode to complete parameter settings at one time, implementing centralized monitoring and management. Do not use the single rack and single module mode.**

Except the preceding requirements, the modular UPS shall have general features of the common UPS, such as supporting various communication ports, web access, automatic sending of fault alarms, visual network management system platform, and providing communication protocols for interaction with third-party network management systems.

### **3.5 Choosing a Modular UPS According to the Manufacturing Process (such as the mechanical part, guide rail, conformal coating, and manufacturing process)**

**Requirements on mechanical parts:** As the power density of the modular UPS is high, the mechanical parts in the cabinet must have strong bearing capability. In some special regions, the shock resistance capability is required. At the same time, the vendors are required to provide shockproof reinforcement components and valid supporting documents that prove the mechanical parts pass related shock resistance tests. The points connected by copper bars must be able to bear the maximum current of the UPS, and the temperature must be within the normal range.

Power modules and bypass modules in the modular UPS system are hot swapped. Therefore, the requirement on the manufacturing process of modules is high. For example, the module size must be strictly consistent. Otherwise, the module cannot be correctly inserted. Connectors must be strictly tested to prevent poor contact or deformation after being connected to modules for multiple times. To facilitate maintenance, guide trails need to be configured in power module slots. In addition, mechanical parts shall have smooth edges and be easy to operate and maintain.

**Environmental defense:** Many UPSs are not put into use immediately after delivery but stored in warehouses of agents for a long period. In some regions where the weather is hot and wet such as Guangdong and Hainan, machines that are stored for a long period are generally rusted and mouldy. In some industrial and mining enterprises or data centers where the environment is poor, dust affects UPSs, for example, blocking the air vent or leading to short-circuit of internal components. Therefore, vendors who focus on quality conduct rustproof processing on the shell of the devices and paint internal boards with the conformal coating to improve the anti-salt spray, anticorrosion, and anti-dust capabilities of the UPS. **In southern areas and regions with poor environment,**

users requires more advanced protection technology, for example, painting internal main board with the conformal coating.

**Requirements on key components:** Components frequently used by the UPS are the IGBT, DSP, and circuit breaker. Small vendors in China will use components with poor quality to reduce the cost. Therefore, users must require vendors to use components from international famous brands, such as ABB and Schneider, as key components. Purchasing documents of important raw materials (such as the battery, circuit breaker, and power component) are required to prevent vendors from selling shoddy goods at best quality prices.

### **3.6 Choosing a Modular UPS According to the Post-sales Service (such as the vendor strength, delivery capability, maintenance office, and spare part purchasing)**

A lot of vendors manufacture UPSs, and their qualities are irregularity. How do users choose a UPS brand?

**First, choose a vendor with the in-house R&D strength.** UPSs are sold mainly in agent sales and factory direct sales modes. Low-power UPSs are sold by agents, while high-power UPSs are sold by both vendors and agents. Therefore, UPSs are classified into agent UPSs and original factory UPSs (some agents declare that UPSs in the original equipment manufacturer (OEM) mode are products of their own). Users shall choose a large agent or vendor to prevent maintenance disputes, require the vendor or agent to provide the original supporting documents, and query information about the vendor such as the personnel scale, production scale, and sales data, to ensure that UPSs are self-developed by the vendor, preventing the situation that technical personnel cannot resolve problems in real time.

**Second, choose a vendor who provides post-sales services.** Generally, large vendors set service offices all over the country (some large companies set service offices in major countries all over the world). Therefore, compared with small vendors, the troubleshooting speed and maintenance personnel quality are much better. If purchasing UPSs from an agent, you should require the agent to provide corresponding maintenance services and maintenance qualification authorized by the vendor.

**Third, choose a vendor with whom you can cooperate for a long period.** The competition in the UPS industry is fierce. Acquisition and integration are intensified in the UPS industry. Many vendors with insufficient strength will be merged or washed out. If users choose these vendors, it is difficult to obtain subsequent maintenance services and purchase spare parts. Therefore, users who intend to perform a long-term planning and focus on stable partnerships should choose products (especially the high-power modular UPSs that have high requirements on technologies) from large enterprises. The quality of products from large vendors is more trustworthy. If the purchase amount is large, users can request to visit the vendor and observe the strength and level of the vendor closely, and then decide whether to purchase products from this vendor.

### **3.7 FAQs**

#### **1. Does a Bypass Module Need to Support Hot Swap?**

According to the analysis result of reliability, in the modular UPS system, the bypass module is the key to control the reliability of the system. As the centralized bypass has no redundancy design (although the distributed bypass has high reliability, the overload risk exists), the bypass module needs to support hot swap.

## 2. Does High-density Power Affect the Heat Dissipation of UPSs?

During the design of the modular UPS, strict thermal simulation analysis is generally implemented. During research and development, a large number of experiments are conducted to test the temperature of each part of the machine to ensure thermal uniformity of internal components in the UPS. Fans are configured in a power module to implement forced air cooling to ensure that the heat inside the product can be dissipated in real time. Good quality products have the design such as intelligent rate control of fans and fan redundancy to improve the overall reliability of fans and the UPS. In addition, the working temperature range of the UPS can be viewed. UPSs with good quality can work in high ambient temperatures.

## 4. Summary

Choosing a modular UPS needs to consider multiple factors. Users can reference Table 5 to choose a modular UPS in a quick manner.

**Table 5** Evaluation on indicators of a modular UPS

	Indicator	Evaluation Standard
External feature	Volume and weight	The smaller and lighter, the better.
	System capacity	The maximum number of modules is 20.
	Capacity and weight of a module	The capacity of a module ranges from 20 kVA to 50 kVA, and the weight is within 40 kg.
Electrical property	Efficiency	The efficiency is higher than 95%. The higher, the better.
	Input/output PF	The higher, the better. The input PF is larger than 0.99, and the output PF is larger than 0.9.
	Hibernation and energy saving	A modular UPS has the hibernation and energy saving functions.

	Harmonic current and current equalization rate	The harmonic current and current equalization rate comply with the national and international standards.
<b>System design</b>	Control mode of a power module	Both centralized and distributed control modes can be used. However, single point failure must be avoided.
	Bypass control mode	The centralized bypass is used to prevent power modules from decentralizing the bypasses.
<b>Usability design</b>	Hot swap	Power, monitoring, and bypass modules must support hot swap.
	System monitoring mode	The centralized unified monitoring mode is used to prevent independent rack or module control.
<b>Manufacturing process</b>	Manufacturing process of mechanical parts	Mechanical parts pass the shock resistance test, have guide trails that facilitate module removing and inserting, and have smooth edges.
	Environmental defense	Anti-dust, moisture-proof, and anticorrosion measures are provided.
	Key components	Circuit breakers and IGBT from international famous brands are used.
<b>Post-sales service</b>	Strength and post-sales services of a vendor	The vendor has the in-house R&D capability, has many post-sales service offices that respond quickly, and provides products with good quality.