



CloudEngine 8800&7800&6800&5800 Series Switches

M-LAG Technology White Paper

Issue 03

Date 2016-01-05

Copyright © Huawei Technologies Co., Ltd. 2016. All rights reserved.

No part of this document may be reproduced or transmitted in any form or by any means without prior written consent of Huawei Technologies Co., Ltd.

Trademarks and Permissions



HUAWEI and other Huawei trademarks are trademarks of Huawei Technologies Co., Ltd.

All other trademarks and trade names mentioned in this document are the property of their respective holders.

Notice

The purchased products, services and features are stipulated by the contract made between Huawei and the customer. All or part of the products, services and features described in this document may not be within the purchase scope or the usage scope. Unless otherwise specified in the contract, all statements, information, and recommendations in this document are provided "AS IS" without warranties, guarantees or representations of any kind, either express or implied.

The information in this document is subject to change without notice. Every effort has been made in the preparation of this document to ensure accuracy of the contents, but all statements, information, and recommendations in this document do not constitute a warranty of any kind, express or implied.

Huawei Technologies Co., Ltd.

Address: Huawei Industrial Base
Bantian, Longgang
Shenzhen 518129
People's Republic of China

Website: <http://e.huawei.com>

Contents

1 M-LAG Configuration.....	1
1.1 Introduction to M-LAG.....	2
1.2 Principles.....	2
1.2.1 Basic Concepts.....	3
1.2.2 Implementation.....	4
1.3 Application Scenario.....	18
1.4 Configuration Task Summary.....	20
1.5 Configuration Notes.....	22
1.6 Configuring M-LAG.....	25
1.6.1 Configuring M-LAG Through the Root Bridge.....	25
1.6.2 Configuring M-LAG Through V-STP (Recommended).....	37
1.7 Configuration Examples.....	49
1.7.1 Example for Deploying M-LAG to Connect the Device to an Ethernet Network in Dual-Homing Mode Through the Root Bridge.....	49
1.7.2 Example for Deploying M-LAG to Connect the Device to an Ethernet Network in Dual-Homing Mode Through the Root Bridge Mode and a Heartbeat Line.....	57
1.7.3 Example for Deploying M-LAG on a Dual-Homing TRILL Network Through V-STP.....	65
1.7.4 Example for Dual-Homing a Switch to an IP Network Through V-STP.....	72
1.7.5 Example for Configuring VXLAN All-Active Access (In Single-Node Mode).....	79
1.7.6 Example for Configuring Multi-level M-LAG Interconnection.....	87

1 M-LAG Configuration

About This Chapter

This chapter describes how to configure Multichassis Link Aggregation Group (M-LAG).

[1.1 Introduction to M-LAG](#)

[1.2 Principles](#)

[1.3 Application Scenario](#)

[1.4 Configuration Task Summary](#)

[1.5 Configuration Notes](#)

[1.6 Configuring M-LAG](#)

[1.7 Configuration Examples](#)

1.1 Introduction to M-LAG

Definition

Multichassis Link Aggregation Group (M-LAG) implements link aggregation among multiple devices. In a dual-active system shown in [Figure 1-1](#), one device is connected to two devices through M-LAG to achieve device-level link reliability.

Figure 1-1 M-LAG network

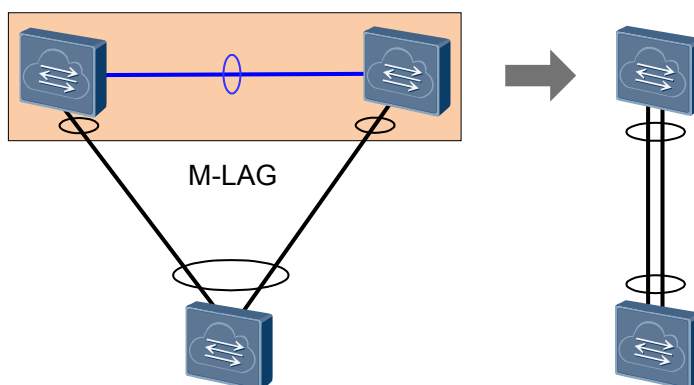

Purpose

As an inter-device link aggregation technology, M-LAG increases link bandwidth, improves link reliability, and implements load balancing. It has the following advantages:

- High reliability
M-LAG protects link reliability for entire devices.
- Simplified network and configuration
M-LAG is a horizontal virtualization technology that virtualizes two dual-homed devices into one device. M-LAG prevents loops on a Layer 2 network and implements redundancy, without performing laborious spanning tree protocol configuration. M-LAG greatly simplifies the network and configuration.
- Independent upgrade
Two devices can be upgraded independently. This prevents service interruption when either device is upgrading.

Reference

Infographic: M-LAG

1.2 Principles

1.2.1 Basic Concepts

As shown in **Figure 1-2**, the user-side device (switch or host) connects to SwitchA and SwitchB through M-LAG to constitute a dual-active system. Then SwitchA and SwitchB forward traffic together to ensure network reliability.

Figure 1-2 M-LAG network

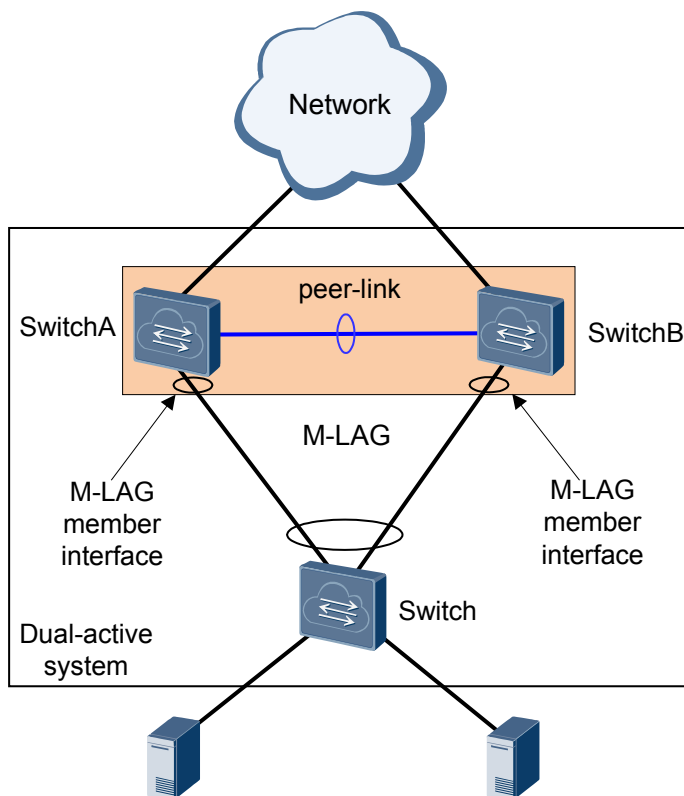

Table 1-1 describes basic concepts of M-LAG.

Table 1-1 Basic concepts of M-LAG

Concept	Description
M-LAG master device	The device is configured with M-LAG and is in master state.
M-LAG backup device	The device is configured with M-LAG and is in slave state. NOTE Normally, both the master and backup devices forward service traffic.
Peer-link	A peer-link is between two directly connected devices and has M-LAG configured. It is used to exchange negotiation packets and transmit part of traffic. To ensure the reliability of the peer-link, you are advised to use multiple links for aggregation.
Peer-link interface	The peer-link interfaces are on two ends of a peer-link.

Concept	Description
M-LAG member interface	M-LAG member interfaces are the Eth-Trunks on M-LAG master and backup devices that are connected to the user-side host or switch. To improve reliability, you are advised to configure link aggregation in LACP mode.

1.2.2 Implementation

The dual-active system that is set up based on M-LAG provides device-level reliability.

Figure 1-3 shows the M-LAG establishment process. The process includes the following stages:

1. The devices at both ends of the M-LAG periodically send M-LAG negotiation packets through the peer-link. When receiving M-LAG negotiation packets from the remote end, the local end determines whether a DFS group ID in the M-LAG negotiation packets is the same as that on the local end. If they are the same, device pairing is successful.
2. Both devices compare the DFS group priority in M-LAG negotiation packets to determine the master and slave status. SwitchB is used as an example. When receiving packets from SwitchA, SwitchB checks and records information about SwitchA, and compares its DFS group priority with that of SwitchA. If SwitchA has a higher DFS group priority than SwitchB, SwitchA is the master device and SwitchB is the backup device. If SwitchA and SwitchB have the same DFS group priority, the device with a smaller MAC address functions as the master device.

The master and slave statuses take effective when a fault occurs, and do not affect traffic forwarding.

3. After master and backup devices are negotiated, the two devices periodically send M-LAG heartbeat packets (heartbeat detection can be also used) through the network-side link. When two devices can receive packets from each other, the dual-active system starts to work.

M-LAG heartbeat packets are used to detect dual master devices when the peer-link fails.

4. The two devices send M-LAG synchronization packets through the peer-link to synchronize information from each other in real time. M-LAG synchronization packets include MAC address entries and ARP entries, so a fault of any device does not affect traffic forwarding.

Figure 1-3 M-LAG setup

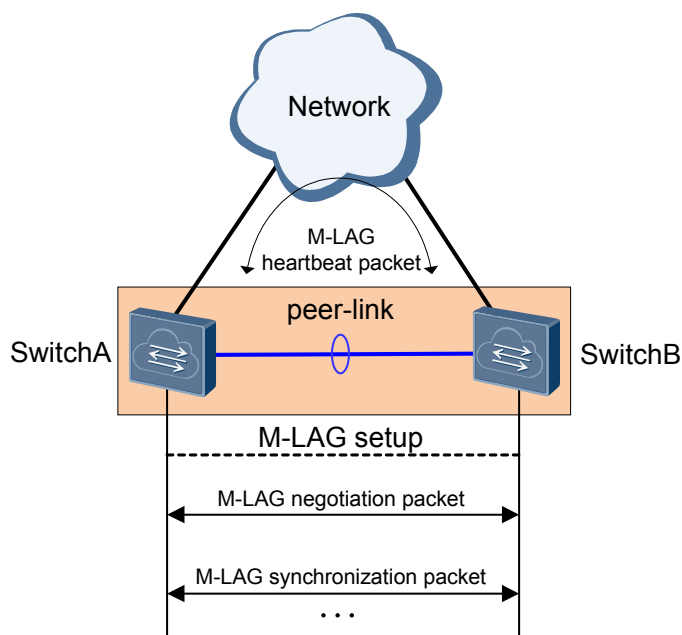

After the M-LAG dual-active system is set up successfully, the M-LAG dual-active system starts to work. The M-LAG master and backup devices load balance traffic. If a link, device, or peer-link fault occurs, M-LAG ensures nonstop service transmission. The following describes traffic forwarding when M-LAG works properly and a fault occurs.

Dual homing a switch to a Ethernet network and an IP network is used as an example.

NOTE

For details on dual homing a switch to a TRILL network, see TRILL Multi-Homing Active-Active Access in *CloudEngine 8800&7800&6800&5800 Series Switches Configuration Guide - DCN and Server Management - TRILL Configuration*.

For details on dual homing a switch to a VXLAN network, see VXLAN Dual-Active Access in *CloudEngine 8800&7800&6800&5800 Series Switches Configuration Guide - DCN and Server Management - VXLAN Configuration*.

Dual Homing a Switch to an Ethernet Network

The network is normal:

Table 1-2 Traffic forwarding in a normal situation

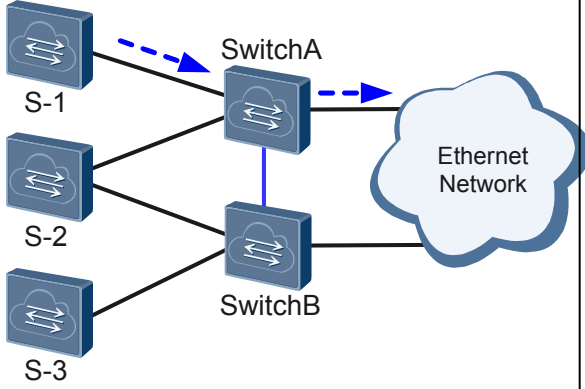
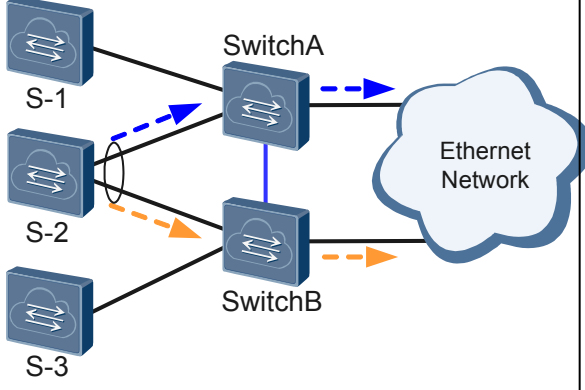
Traffic Type	Traffic Forwarding	Traffic Processing
<p>Unicast traffic from a non-M-LAG member interface (S-1 for example)</p>	<p>Figure 1-4 Unicast traffic from a non-M-LAG member interface</p> 	<p>Device forwards unicast traffic based on the common forwarding process.</p>
<p>Unicast traffic from an M-LAG member interface</p>	<p>Figure 1-5 Unicast traffic from an M-LAG member interface</p> 	<p>SwitchA and SwitchB load balance traffic.</p>

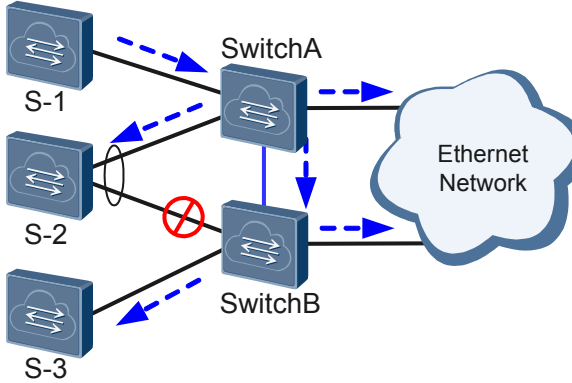
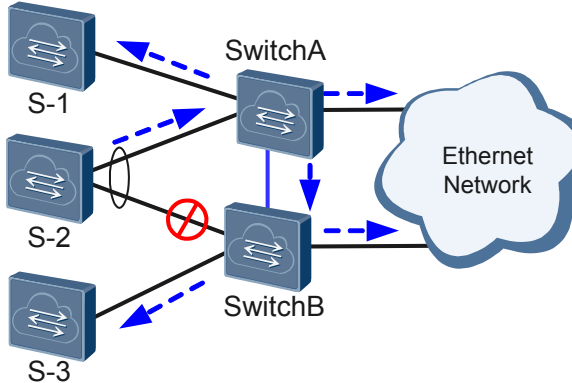
Traffic Type	Traffic Forwarding	Traffic Processing
<p>Multicast or broadcast traffic from a non-M-LAG member interface (S-1 for example)</p>	<p>Figure 1-6 Multicast or broadcast traffic from a non-M-LAG member interface</p> 	<p>After receiving multicast traffic, SwitchA forwards traffic to each next hop. The traffic that reaches SwitchB is not forwarded to S-2 because unidirectional isolation is configured between the peer-link and M-LAG member interface.</p>
<p>Multicast or broadcast traffic from an M-LAG member interface</p>	<p>Figure 1-7 Multicast or broadcast traffic from an M-LAG member interface</p> 	<p>Multicast or broadcast traffic from S-2 is load balanced between SwitchA and SwitchB. The following uses the forwarding process on SwitchA as an example.</p> <p>After receiving multicast traffic, SwitchA forwards traffic to each next hop. The traffic that reaches SwitchB is not forwarded to S-2 because unidirectional isolation is configured between the peer-link and M-LAG member interface.</p>

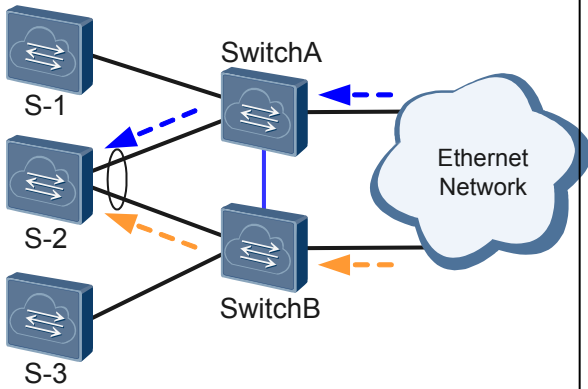
Traffic Type	Traffic Forwarding	Traffic Processing
<p>Unicast traffic from the network side</p>	<p>Figure 1-8 Unicast traffic from the network side</p>  <p>The diagram illustrates the traffic forwarding process. An Ethernet Network (cloud) sends traffic to three switches: S-1, S-2, and S-3. SwitchA and SwitchB are connected to the Ethernet Network. SwitchA is connected to S-1 and S-2. SwitchB is connected to S-2 and S-3. Traffic from the Ethernet Network to S-1 is shown as a solid blue arrow going directly to S-1. Traffic from the Ethernet Network to S-2 and S-3 is shown as dashed blue arrows going to SwitchA and dashed orange arrows going to SwitchB, indicating load balancing.</p>	<p>Unicast traffic sent from the network side to M-LAG member interfaces is forwarded to the dual-active devices by SwitchA and SwitchB in load balancing mode. Load balancing is not performed for unicast traffic sent from the network side to non-M-LAG member interfaces. For example, traffic sent to S-1 is directly sent to SwitchA, which then forwards the traffic to S-1.</p>

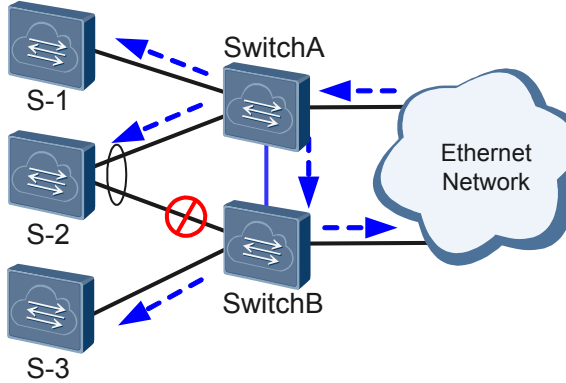
Traffic Type	Traffic Forwarding	Traffic Processing
<p>Multicast or broadcast traffic from the network side</p>	<p>Figure 1-9 Multicast or broadcast traffic from the network side</p> 	<p>Multicast or broadcast traffic from the network side is load balanced between SwitchA and SwitchB. The following uses the forwarding process on SwitchA as an example.</p> <p>SwitchA forwards traffic to each user-side interface. The traffic that reaches SwitchB is not forwarded to S-2 because unidirectional isolation is configured between the peer-link and M-LAG member interface.</p>

A fault occurs:

- Peer-link fails

Figure 1-10 Peer-link fails

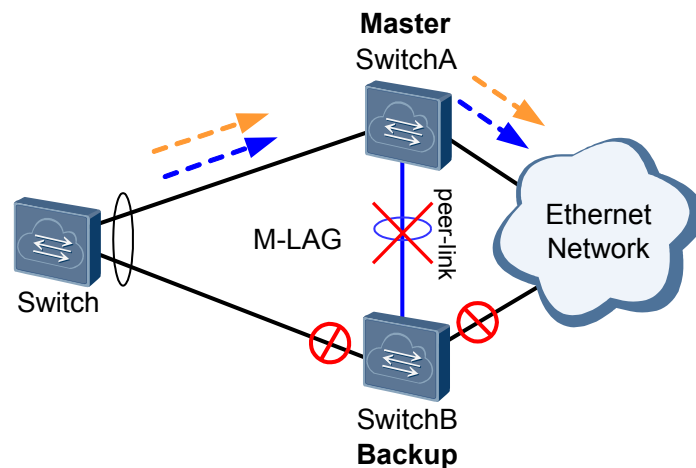

When the peer-link fails but the heartbeat status is normal, all physical interfaces except the management interface, peer-link interface, and stack interface on the backup device enter the Error-Down state. When the peer-link recovers, the physical interfaces in Error-Down state are restored after 2 minutes by default. In an SVF of fixed and modular switches, the physical interfaces in Error-Down state on a leaf switch are restored after 5 minutes by default. When the peer-link fails, the Eth-Trunk on the master device is still Up, and the Eth-Trunk on the backup device becomes Down. Therefore, the dual-homing topology changes into a single-homing topology.

You can run the **m-lag unpaired-port suspend** command to specify the interfaces that need to enter the Error-Down state when the peer-link fails, and the interfaces that are not specified will not enter the Error-Down state.

- M-LAG master device fails

Figure 1-11 M-LAG master device fails

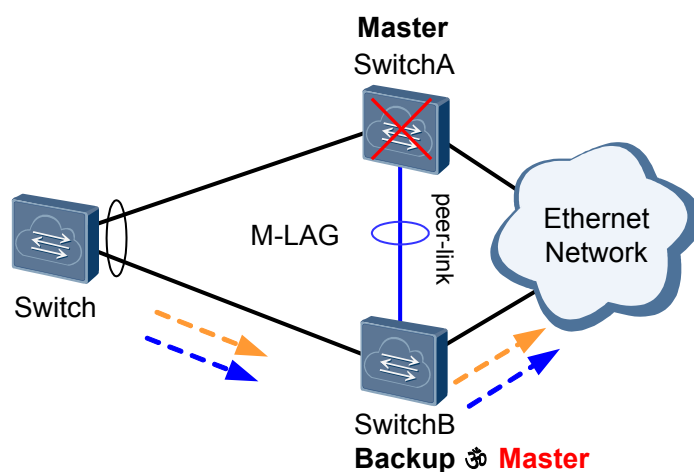

The M-LAG backup device becomes the master device and continues forwarding traffic, and its Eth-Trunk is still in Up state. The Eth-Trunk on the master device becomes Down, and the dual-homing networking changes into a single-homing networking. The status of the M-LAG master and backup device remains unchanged. That is, when the M-LAG master device fails, the M-LAG backup device that becomes the master device remains in master state and the faulty M-LAG master device that recovers is still the backup device.

NOTE

If the M-LAG backup device fails, the master and backup states remain unchanged and the Eth-Trunk of the M-LAG backup device becomes Down. The Eth-Trunk on the master device is still in Up state and continues forwarding traffic. The dual-homing networking changes into a single-homing networking.

- Downlink Eth-Trunk fails

Figure 1-12 Downlink Eth-Trunk fails

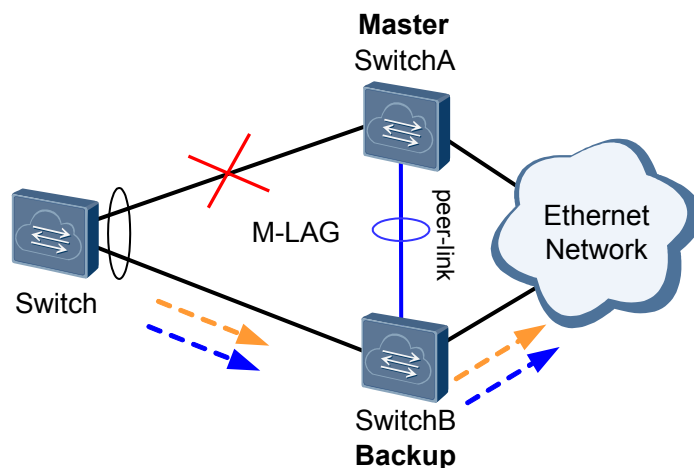

The M-LAG master and backup states remain unchanged, and traffic is switched to the other Eth-Trunk. The faulty Eth-Trunk becomes Down, and the dual-homing networking changes into a single-homing networking.

- Uplink fails

Figure 1-13 Uplink fails

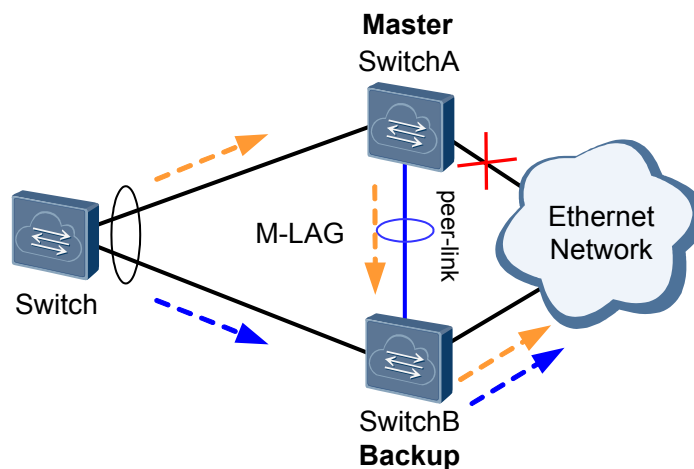

When a switch is dual-homed to an Ethernet network, heartbeat packets are often transmitted through the management network. Heartbeat detection on the M-LAG master device is not affected, the dual-active system is not affected, and the M-LAG master and backup devices can still forward traffic. Because the uplink of the M-LAG master device fails, traffic passing the M-LAG master device is forwarded through the peer-link.

Dual Homing a Switch to an IP Network

The network is normal:

Table 1-3 Traffic forwarding in a normal situation

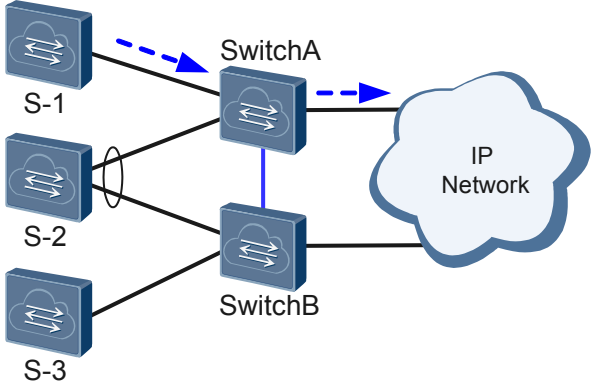
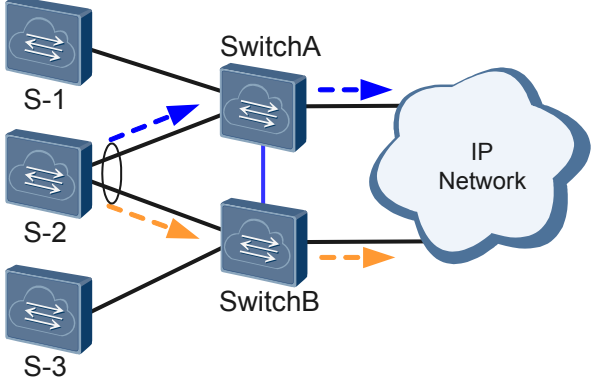
Traffic Type	Traffic Forwarding	Traffic Processing
<p>Unicast traffic from a non-M-LAG member interface (S-1 for example)</p>	<p>Figure 1-14 Unicast traffic from a non-M-LAG member interface</p> 	<p>Device1 forwards unicast traffic based on the common forwarding process.</p>
<p>Unicast traffic from an M-LAG member interface</p>	<p>Figure 1-15 Unicast traffic from an M-LAG member interface</p> 	<p>SwitchA and SwitchB load balance traffic.</p>

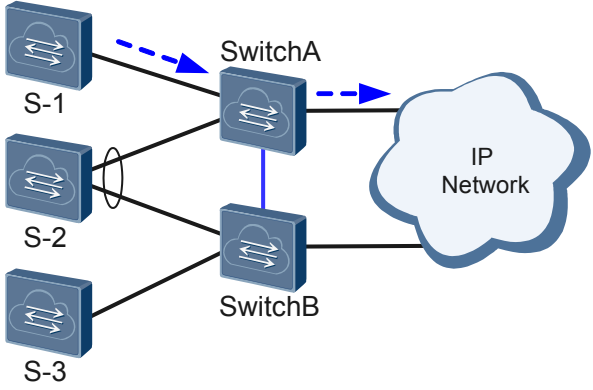
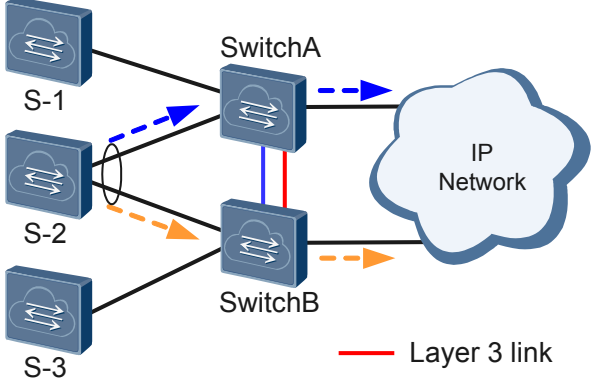
Traffic Type	Traffic Forwarding	Traffic Processing
<p>Multicast traffic from a non-M-LAG member interface (S-1 for example)</p>	<p>Figure 1-16 Multicast traffic from a non-M-LAG member interface</p> 	<p>The forwarding path of multicast traffic depends on the selected routes.</p>
<p>Multicast traffic from an M-LAG member interface</p>	<p>Figure 1-17 Multicast traffic from an M-LAG member interface</p> 	<p>SwitchA and SwitchB load balance traffic.</p> <p>NOTE To ensure normal Layer 3 multicast transmission on the M-LAG, a Layer 3 direct link (line marked in red) needs to be deployed between the M-LAG master and backup devices.</p>

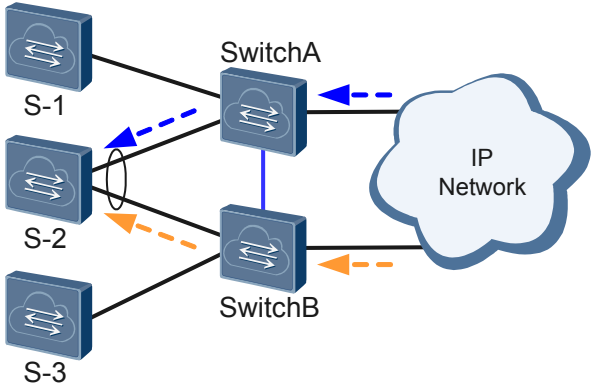
Traffic Type	Traffic Forwarding	Traffic Processing
<p>Unicast traffic from the network side</p>	<p>Figure 1-18 Unicast traffic from the network side</p>  <p>The diagram illustrates the traffic forwarding path for unicast traffic from the network side. It shows three destination switches labeled S-1, S-2, and S-3. Two M-LAG switches, SwitchA and SwitchB, are connected to these destination switches. An IP Network is connected to both SwitchA and SwitchB. Traffic from the IP Network to S-1 is shown as a blue dashed arrow going directly to SwitchA. Traffic from the IP Network to S-2 and S-3 is shown as orange dashed arrows being load-balanced between SwitchA and SwitchB. A blue dashed arrow also shows traffic from SwitchA to S-1.</p>	<p>Unicast traffic sent from the network side to M-LAG member interfaces is forwarded to the dual-active devices by SwitchA and SwitchB in load balancing mode. Load balancing is not performed for unicast traffic sent from the network side to non-M-LAG member interfaces. For example, traffic sent to S-1 is directly sent to SwitchA, which then forwards the traffic to S-1.</p>

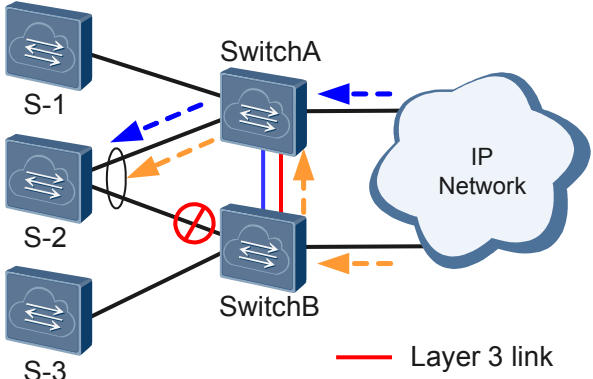
Traffic Type	Traffic Forwarding	Traffic Processing
<p>Multicast traffic from the network side</p>	<p>Figure 1-19 Multicast traffic from the network side</p>  <p>The diagram illustrates a network topology where an IP Network (cloud) is connected to two M-LAG member devices, SwitchA (master) and SwitchB (backup). SwitchA and SwitchB are connected to three downstream switches: S-1, S-2, and S-3. A red line represents a Layer 3 link between SwitchA and SwitchB. Orange dashed arrows show traffic flow from the IP Network through SwitchA to S-1, S-2, and S-3. Blue dashed arrows show traffic flow from the IP Network through SwitchB to S-1 and S-2. A red circle with a slash is placed over the link between SwitchB and S-2, indicating a fault.</p>	<p>Normally, network-side multicast traffic is forwarded to S-2 through the M-LAG master device (SwitchA) only. The M-LAG backup device (SwitchB) cannot forward multicast traffic through M-LAG member interfaces.</p> <p>NOTE</p> <p>To ensure normal Layer 3 multicast transmission on the M-LAG, a Layer 3 direct link (line marked in red) needs to be deployed between the M-LAG master and backup devices. Some multicast traffic can be forwarded through the Layer 3 link.</p>

A fault occurs:

- Peer-link fails

Figure 1-20 Peer-link fails

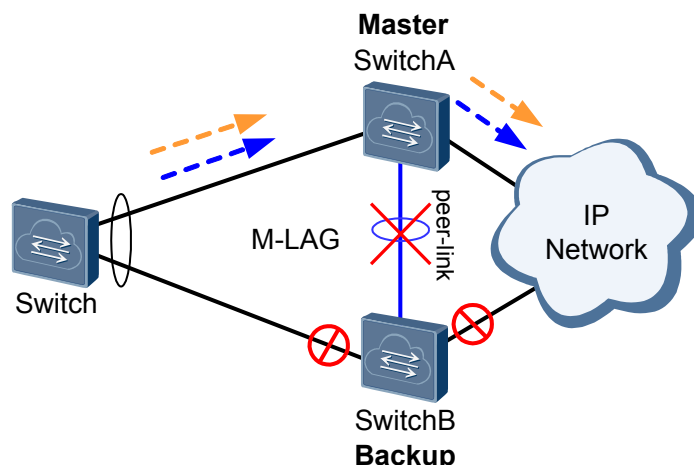

When the peer-link fails but the heartbeat status is normal, all physical interfaces except the management interface, peer-link interface, and stack interface on the backup device enter the Error-Down state. When the peer-link recovers, the physical interfaces in Error-Down state are restored after 2 minutes by default. In an SVF of fixed and modular switches, the physical interfaces in Error-Down state on a leaf switch are restored after 5 minutes by default. When the peer-link fails, the Eth-Trunk on the master device is still Up, and the Eth-Trunk on the backup device becomes Down. Therefore, the dual-homing topology changes into a single-homing topology.

You can run the **m-lag unpaired-port suspend** command to specify the interfaces that need to enter the Error-Down state when the peer-link fails, and the interfaces that are not specified will not enter the Error-Down state.

- M-LAG master device fails

Figure 1-21 M-LAG master device fails

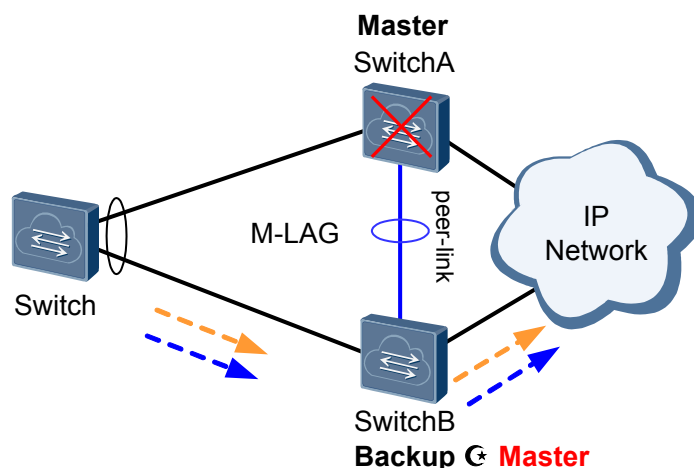

The M-LAG backup device becomes the master device and continues forwarding traffic, and its Eth-Trunk is still in Up state. The Eth-Trunk on the master device becomes Down, and the dual-homing networking changes into a single-homing networking.

 **NOTE**

If the M-LAG backup device fails, the master and backup states remain unchanged and the Eth-Trunk of the M-LAG backup device becomes Down. The Eth-Trunk on the master device is still in Up state and continues forwarding traffic. The dual-homing networking changes into a single-homing networking.

- Downlink Eth-Trunk fails

Figure 1-22 Downlink Eth-Trunk fails

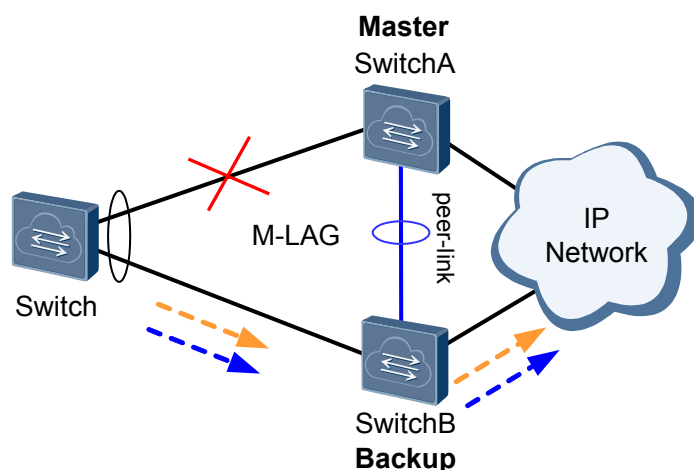

The M-LAG master and backup states remain unchanged, and traffic is switched to the other Eth-Trunk. The faulty Eth-Trunk becomes Down, and the dual-homing networking changes into a single-homing networking.

- Uplink fails

Figure 1-23 Uplink fails

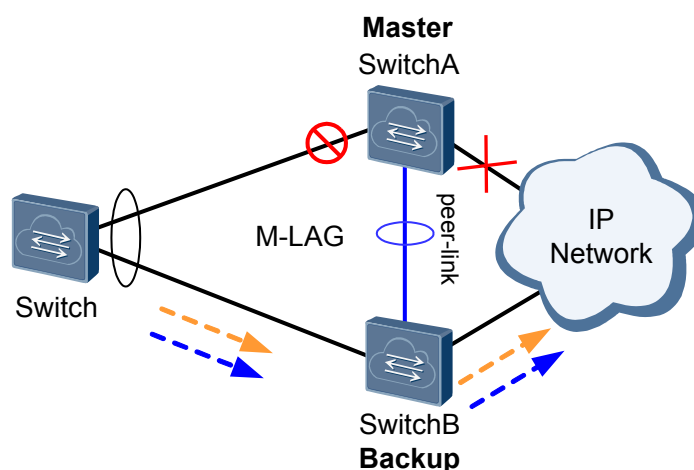

Because the M-LAG backup device does not receive heartbeat packets, the M-LAG backup device becomes the master device. The user-side traffic that reaches SwitchA cannot be forwarded through the peer-link and there is no available uplink outbound interface. Consequently, SwitchA discards all user traffic. To address this issue, associate uplink and downlink interfaces with a Monitor Link group on M-LAG master and backup interfaces. Monitor Link enables the downlink interface to become Down when

the downlink outbound interface becomes Down, preventing user-side traffic from being discarded. For the configuration procedure, see [\(Optional\) Associating Uplink and Downlink Interfaces with a Monitor Link Group](#).

1.3 Application Scenario

M-LAG mainly applies to scenarios where a server or switch is dual-homed to an Ethernet, Transparent Interconnection of Lots of Links (TRILL), Virtual eXtensible Local Area Network (VXLAN), or IP network. It provides load balancing and backup. M-LAG falls into single-level and multi-level LAG.

Single-level M-LAG

- **Connecting a switch in dual-homing mode**

As shown in [Figure 1-24](#), to ensure reliability, a switch is connected to a network to implement link redundancy. MSTP can be deployed to implement redundancy, but the link use efficiency is low and many bandwidth resources are wasted. To implement redundancy and improve the link use efficiency, deploy M-LAG between SwitchA and SwitchB so that the switch can be dual-homed to SwitchA and SwitchB. SwitchA and SwitchB load balance traffic. When one device fails, traffic can be rapidly switched to the other device to ensure nonstop service transmission.

Figure 1-24 Connecting a switch in dual-homing mode

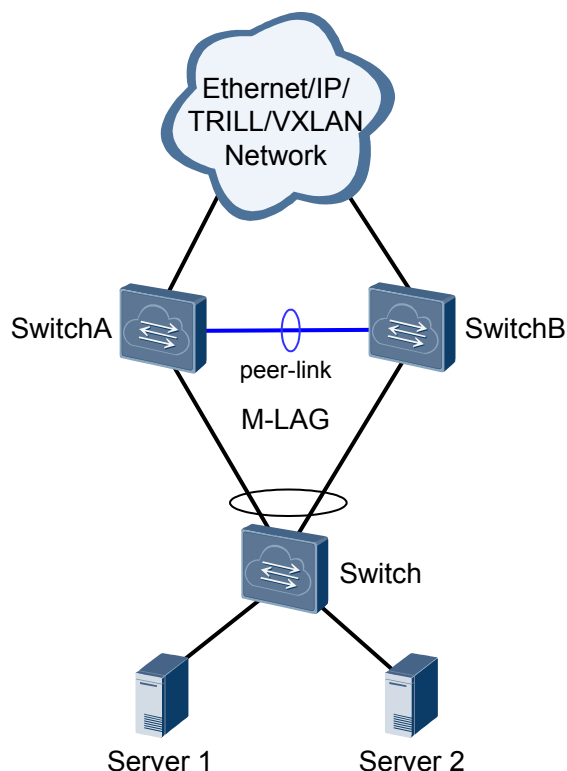

- **Connecting a server in dual-homing mode**

As shown in [Figure 1-25](#), to ensure reliability, a server is often connected to a network through link aggregation. If the device connected to the server fails, services are interrupted. To prevent this problem, a server can connect to a network through M-LAG.

That is, deploy M-LAG between SwitchA and SwitchB and connect the server to SwitchA and SwitchB. SwitchA and SwitchB load balance traffic. When one device fails, traffic can be rapidly switched to the other device to ensure nonstop service transmission.

 **NOTE**

The configuration of dual homing a server is the same as common link aggregation configuration. Ensure that the server and switches use the same link aggregation mode. The LACP mode at both ends is recommended.

Figure 1-25 Connecting a server in dual-homing mode

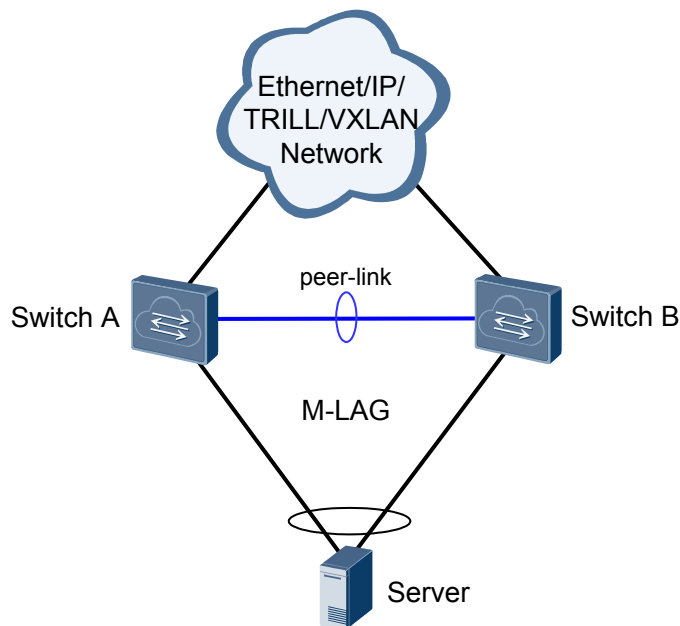

Multi-level M-LAG

As shown in [Figure 1-26](#), after M-LAG is deployed between SwitchA and SwitchB, M-LAG is deployed between SwitchC and SwitchD. The two M-LAGs are connected. This deployment simplifies networking and allows more servers to be connected to the network in dual-homing mode. Before deploying multi-level M-LAG, configure Virtual Spanning Tree Protocol (V-STP).

Figure 1-26 Networking of multi-level M-LAG

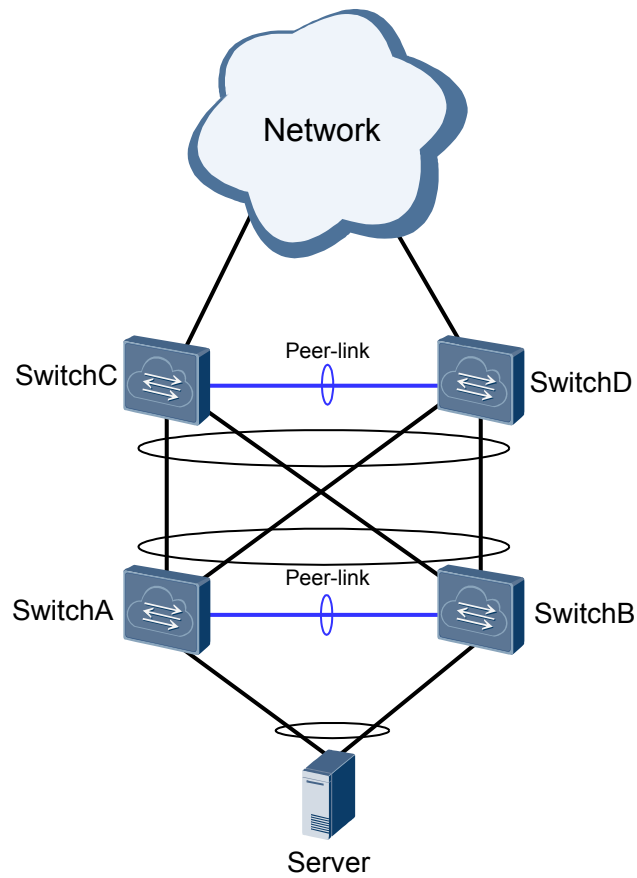

1.4 Configuration Task Summary

You can perform the following M-LAG configuration according to the actual networking.

Table 1-4 M-LAG configuration tasks

Mode	Description	Task	Configuration Notes
Root bridge	When the root bridge mode is used to configure M-LAG, the M-LAG master and backup devices must be used as root bridges and configured with the same bridge ID on the STP network so that the two devices are simulated into one root bridge. The M-LAG master and backup devices are not affected by the network topology change on the Layer 2 network.	<ol style="list-style-type: none"> 1. Configuring the Root Bridge and Bridge ID 2. Configuring a DFS Group 3. Configuring an Interface as a Peer-link Interface 4. Configuring an M-LAG Member Interface 5. (Optional) Configuring the Dual-Active Gateway 6. (Optional) Associating Uplink and Downlink Interfaces with a Monitor Link Group 7. (Optional) Configuring an Interface in Error-Down State 	<ul style="list-style-type: none"> ● Configure the M-LAG master and backup devices as root bridges and configure the same bridge ID for them. ● STP must be disabled on the peer-link interface.
Recommended V-STP	V-STP virtualizes the M-LAG master and backup devices enabled with STP into one device to perform STP calculation.	<ol style="list-style-type: none"> 1. Configuring V-STP 2. Configuring a DFS Group 3. Configuring an Interface as a Peer-link Interface 4. Configuring an M-LAG Member Interface 5. (Optional) Configuring the Dual-Active Gateway 6. (Optional) Associating Uplink and Downlink Interfaces with a Monitor Link Group 7. (Optional) Configuring an Interface in Error-Down State 	You must enable STP on the peer-link interface and configure global V-STP.

 **NOTE**

- When the root bridge mode is used, two devices that constitute an M-LAG must function as root bridges on a Layer 2 network and do not support M-LAG cascading.
- When the V-STP mode is used, two devices that constitute an M-LAG can choose not to function as root bridges on a Layer 2 network. The networking is flexible and the two devices support M-LAG cascading. V-STP is recommended because it can eliminate loops caused by incorrect M-LAG configurations or connections.

1.5 Configuration Notes

Involved Network Element

Other network elements are not required.

License Support

M-LAG is a basic function, and can be used without a license.

Version Support

Table 1-5 Products and minimum version supporting M-LAG

Series	Product	Minimum Version Required
CE8800	CE8860EI	V100R006C00
CE7800	CE7850EI	V100R005C10
	CE7855EI	V200R001C00
CE6800	CE6810EI	V100R005C10
	CE6810LI	V100R005C10
	CE6850EI	V100R005C10
	CE6850HI	V100R005C10
	CE6855HI	V200R001C00
	CE6860EI	V200R001C00
	CE6870EI	V200R001C00
CE5800	CE5810EI	V100R005C10
	CE5850EI	V100R005C10
	CE5850HI	V100R005C10
	CE5855EI	V100R005C10

Feature Dependencies and Limitations

Table 1-6 M-LAG specifications

Item	Specification
Number of DFS groups	1
Number of peer-links	1
Number of global M-LAGs	2048

Configuration Notes of M-LAG

- During M-LAG setup, you must use Huawei-certified optical modules or copper transceiver modules. If high-speed cables or active optical cables (AOCs) are used, you must purchase cables from Huawei. Non-Huawei-certified optical or copper transceiver modules, and cables not purchased from Huawei cannot ensure transmission reliability and may affect service stability. Huawei is not liable for any problem caused by non-Huawei-certified optical or copper transceiver modules, or cables not purchased from Huawei, and will not fix such problems.
- The two devices that constitute an M-LAG must use the same model. If one end is an SVF, the other end must be an SVF. If one end is a CE8800&CE7800&6800&5800 series switch, the other end must be a CE8800&CE7800&6800&5800 series switch. It is recommended that devices at both ends use the same model and version.
- The two devices that constitute an M-LAG can be configured with a CSS or an SVF system. When configuring the two devices as an SVF system, pay attention to the following points:
 - Interfaces on the server must connect to either the parent or leaf switch.
 - The peer-link interface must be configured on the parent switch.
- When the root bridge mode is used to configure M-LAG, the two devices that constitute an M-LAG must use the same bridge ID and the highest root priority so that the devices function as the root nodes.
- In V-STP scenarios, the device does not support the MSTP mode or STP multi-process.
- In V-STP scenarios, configure M-LAG and establish connections according to the following sequence:
 - a. Configure V-STP.
 - b. Configure a DFS group and a peer-link interface.
 - c. Use a cable to connect peer-link interfaces of M-LAG master and backup devices.
 - d. Configure the M-LAG member interface and use cables to connect M-LAG master and backup devices and user-side hosts or switching devices.
- To ensure that traffic is forwarded normally, the configurations of M-LAG interfaces with the same M-LAG ID on the master and backup devices must be consistent.
- When the two devices that constitute an M-LAG function as gateways and servers are single-homed or dual-homed to the two devices, pay attention to the following points:
 - When servers connect to the two devices through VRRP or VRRP6, the two devices must be configured with the same VLAN, and VLANIF interfaces must be created. Do not configure strict ARP learning on the VLANIF interfaces; otherwise, ARP

entries cannot be synchronized. When there are many ARP entries, remove the peer-link interface from the VLAN at the access side. It is recommended that the M-LAG member interface at the access side should use the main interface or VLANIF interface (M-LAG member interface on one device).

- When servers connect to the two devices by configuring IP addresses or MAC addresses of VLANIF interfaces (supported since V100R006C00), the two devices support hot standby of MAC address entries or ARP entries, the entry learning time is reduced and traffic interruption is shortened. When the same IP address is configured for VLANIF interfaces, the alarm about the IP address conflict will be generated. To shield the alarm, run the **undo snmp-agent trap enable feature-name arp trap-name hwethernetarpipconflictevent** command to disable the alarm about the IP address conflict.
- To prevent STP flapping caused by device restart and peer-link faults and ensure switching performance, you are advised to set the delay in reporting the Up event to be at least 30s on the M-LAG interface, peer-link interface, and other service interfaces.
- After M-LAG is configured, to modify the peer-link configuration, shut down the peer-link interface. Otherwise, too many packets are transmitted.
- The following networking is not recommended because the STP status on both ends of the M-LAG may be inconsistent, without affecting functions. For example, when you run the **shutdown** and **undo shutdown** commands or run the **restart** command on m-lag 2 of Switch A, the interface changes from the designated interface to the edge interface. However, m-lag 2 of Switch B is still the designated interface.

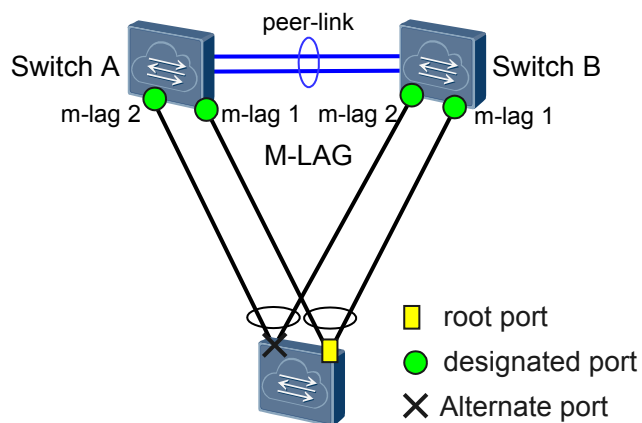

Configuration Notes When M-LAG Is Deployed with Other Services

The support for service features by M-LAG is similar to that by the device, but there are differences, as described in [Table 1-7](#).

Table 1-7 Constraints when M-LAG is used with other features

Feature	Configuration Note
VBST	M-LAG and VBST cannot be configured simultaneously.
GVRP	GVRP and M-LAG cannot be configured on an Eth-Trunk simultaneously..

Feature	Configuration Note
DHCP	<ul style="list-style-type: none"> ● The two devices that constitute an M-LAG cannot be configured with DHCP snooping. ● The DHCP relay function must be configured on the two devices that constitute an M-LAG. ● The DHCP server function must be configured on the two devices that constitute an M-LAG, and addresses in the address pools of the two devices cannot overlap.
IP unicast routing	The two devices that constitute an M-LAG could not setup routing neighbor relationship with the access devices.
IP multicast	<ul style="list-style-type: none"> ● In V100R005C10 and earlier versions, the two devices that constitute an M-LAG cannot be configured with IPv4 Layer 3 multicast. ● The two devices that constitute an M-LAG cannot be configured with bidirectional PIM (IPv4). ● The two devices that constitute an M-LAG cannot be configured with IPv6 multicast. ● On the two devices that constitute an M-LAG, a physical interface that is configured as a Layer 3 interface using the undo portswitch does not support Layer 3 multicast.
FCoE	The M-LAG function is not available if FSB and FCF or FSB and NPV coexist on the device.
IPSG	The two devices that constitute an M-LAG cannot be configured with IPSG.

1.6 Configuring M-LAG

M-LAG implements link aggregation among multiple devices to achieve device-level link reliability.

NOTE

M-LAG must be configured on both devices that constitute a dual-active system.

1.6.1 Configuring M-LAG Through the Root Bridge

When the root bridge mode is used to configure M-LAG, the M-LAG master and backup devices must be used as root bridges and configured with the same bridge ID on the STP network so that the two devices are simulated into one root bridge. The M-LAG master and backup devices are not affected by the network topology change on the Layer 2 network.

Configuring the Root Bridge and Bridge ID

Context

When the root bridge mode is used to configure M-LAG, the M-LAG master and backup devices must be used as root bridges and configured with the same bridge ID on the STP network so that the two devices are simulated into one root bridge. The M-LAG master and backup devices are not affected by the network topology change on the Layer 2 network.

Procedure

Step 1 Run:

```
system-view
```

The system view is displayed.

Step 2 Run:

```
stp [ instance instance-id ] root primary
```

The device is configured as the root bridge.

By default, a switch does not function as the root bridge of any spanning tree. After the configuration is complete, the priority of the device is 0 and cannot be changed.

If **instance** is not specified, the device is the root bridge in instance 0.

Step 3 Run:

```
stp bridge-address mac-address
```

The MAC address of the device that participates in spanning tree calculation is specified.

By default, the device's MAC address is the bridge MAC address of the device that participates in spanning tree calculation.

Step 4 Run:

```
commit
```

The configuration is committed.

---End

Configuring a DFS Group

Context

A Dynamic Fabric Service (DFS) group is used for device pairing. A DFS group needs to be bound to nicknames or IP addresses so that devices at both ends can exchange heartbeat packets. The bound nicknames or IP addresses are used for communication with the remote end. You can bind a DFS group to either a nickname or an IP address in the following situation:

- When a device is dual-homed to a TRILL network, a DFS group needs to be bound to a nickname. Ensure that the nickname has been configured.

On a Transparent Interconnection of Lots of Links (TRILL) dual-active network, you can configure a pseudo nickname for a DFS group. You need to configure the same pseudo nickname on two devices connected to a device on a dual-homing TRILL network. The

remote device considers that one device connects to the TRILL network, and users therefore do not need to consider the network topology.

- When a device is dual-homed to PEs on an Ethernet, VXLAN, or IP network, DFS groups need to be bound to IP addresses. Ensure that IP addresses have been configured for Layer 3 interfaces on two PEs and the two PEs can communicate.

If the device connects to a VPN, you must specify the VPN instance bound to a DFS group. Ensure that the VPN instance has been created.

Procedure

Step 1 Run:

```
system-view
```

The system view is displayed.

Step 2 Run:

```
dfs-group dfs-group-id
```

A DFS group is created and its view is displayed, or the view of an existing DFS group is displayed.

Step 3 Run the following commands as required.

- When a device is dual-homed to a TRILL network, bind a DFS group to a nickname and configure a pseudo nickname.

a. Run:

```
source nickname nickname-value
```

The DFS group is bound to a nickname.

b. Run:

```
pseudo-nickname nickname-value1 [ priority priority ]
```

A pseudo nickname is configured for the DFS group.

- When a device is dual-homed to an Ethernet, VXLAN, or IP network, bind a DFS group to an IP address. Run either of the following commands.

- Run:

```
source ip ip-address [ vpn-instance vpn-instance-name ]
```

The DFS group is bound to an IPv4 address and a VPN instance.

- Run:

```
source ipv6 ipv6-address [ vpn-instance vpn-instance-name ]
```

The DFS group is bound to an IPv6 address and a VPN instance.

Step 4 (Optional) Run:

```
priority priority
```

The priority of the DFS group is set.

The priority of a DFS group is used for master/backup negotiation between two devices. A larger value indicates a higher priority of the device. The device with a higher priority is the master device.

If the priorities of two devices are the same, the device with a smaller MAC address is the master device.

By default, the priority of a DFS group is 100.

Step 5 (Optional) Run:

```
m-lag up-delay value
```

The delay for the M-LAG interface to report the Up event is set.

To ensure the performance of revertive switching, the default delay for the M-LAG interface to report the Up event is 120s in scenarios such as device or Peer-link failure.

Step 6 Run:

```
commit
```

The configuration is committed.

----End

Configuring an Interface as a Peer-link Interface

Context

A peer-link is a direct aggregated link between two devices configured with M-LAG. It is used to exchange protocol packets and transmit some traffic, and ensures normal running of M-LAG.

Prerequisites

The direct link between two devices configured with M-LAG has been configured as an aggregated link.

Procedure

Step 1 Run:

```
system-view
```

The system view is displayed.

Step 2 Run:

```
interface eth-trunk trunk-id
```

The Eth-Trunk interface view is displayed.

Step 3 Run:

```
mode { lacp-static | lacp-dynamic }
```

The Eth-Trunk is configured to work in LACP mode.

By default, an Eth-Trunk works in manual load balancing mode. To ensure M-LAG reliability, you are advised to configure the Eth-Trunk to work in LACP mode.

Step 4 Run:

```
undo stp enable
```

STP is disabled on the interface.

By default, STP is enabled on an interface.

 **NOTE**

STP needs to be disabled because two devices need to be simulated into one STP root bridge and the directly connected interface cannot be blocked.

Step 5 Run:

```
peer-link peer-link-id
```

The interface is configured as a peer-link interface.

By default, no interface is configured as a peer-link interface.

- An interface configured as a peer-link interface joins all VLANs by default.
- An interface configured as a peer-link interface cannot be configured with any service.
- If the ERPS control VLAN, TRILL carrier VLAN, or FCoE VLAN needs to be configured, perform [Step 6](#) to remove the peer-link interface from the control VLAN, carrier VLAN, or FCoE VLAN. Otherwise, the control VLAN, carrier VLAN, or FCoE VLAN cannot be configured.
- If the network-side VLANIF interface is configured, perform [Step 6](#) to remove the peer-link interface from the VLAN. Otherwise, heartbeat detection may take ineffective.

Step 6 (Optional) Run:

```
port vlan exclude { { vlan-id1 [ to vlan-id2 ] } &<1-10> }
```

The VLANs not allowed by the peer-link interface are specified.

By default, no allowed VLAN is specified on a peer-link interface.

Step 7 Run:

```
commit
```

The configuration is committed.

----End

Configuring an M-LAG Member Interface

Prerequisites

The links between a user-side device and two devices configured with M-LAG have been configured as aggregated links. To improve reliability, you are advised to configure link aggregation in LACP mode.

Procedure

- When the Eth-Trunk works in manual load balancing mode, perform the following operations.

a. Run:

```
system-view
```

The system view is displayed.

b. Run:

```
interface eth-trunk trunk-id
```

The Eth-Trunk interface view is displayed.

c. Run:

```
dfs-group dfs-group-id m-lag m-lag-id
```

The Eth-Trunk is bound to a DFS group, that is, the Eth-Trunk is configured as an M-LAG member interface.

 **NOTE**

The two devices configured with M-LAG must use the same M-LAG ID.

- d. Run:

```
commit
```

The configuration is committed.

- When the Eth-Trunk works in LACP mode, perform the following operations.

- a. Run:

```
system-view
```

The system view is displayed.

- b. Run:

```
interface eth-trunk trunk-id
```

The Eth-Trunk interface view is displayed.

- c. Run:

```
mode { lacp-static | lacp-dynamic }
```

The Eth-Trunk is configured to work in LACP mode.

- d. Run:

```
dfs-group dfs-group-id m-lag m-lag-id
```

The Eth-Trunk is bound to a DFS group, that is, the Eth-Trunk is configured as an M-LAG member interface.

 **NOTE**

The two devices configured with M-LAG must use the same M-LAG ID.

- e. Set the LACP M-LAG system priority and ID.

- In the system view:

- 1) Run the **quit** command to exit from the Eth-Trunk interface view.
- 2) Run the **lacp m-lag priority** *priority* command to set the LACP M-LAG system priority.

The default LACP M-LAG system priority is 32768.

- The LACP M-LAG system priority is valid for the M-LAG composed of an Eth-Trunk in LACP mode, whereas the LACP system priority configured by the **lacp priority** command is valid for an Eth-Trunk in LACP mode.
- Eth-Trunks on both devices configured with M-LAG must use the same LACP M-LAG system priority.

- 3) Run the **lacp m-lag system-id** *mac-address* command to set the LACP M-LAG system ID.

By default, the LACP M-LAG system ID in the system view is the MAC address of the Ethernet interface on the MPU.

- The LACP M-LAG system ID is valid for the M-LAG composed of an Eth-Trunk in LACP mode, whereas the LACP system ID is valid for an Eth-Trunk in LACP mode. The default LACP M-LAG system ID is the MAC address of an Ethernet interface on the MPU and cannot be changed.
- Eth-Trunks on both devices configured with M-LAG must use the same LACP M-LAG system ID.

- In the Eth-Trunk interface view:
 - 1) Run the **lACP m-lag priority** *priority* command to set the LACP M-LAG system priority.

There is no default LACP M-LAG system priority in the Eth-Trunk interface view.

 - Eth-Trunks on both devices configured with M-LAG must use the same LACP M-LAG system priority.
 - The LACP M-LAG system priority configured in the system view takes effect for all Eth-Trunks. The LACP M-LAG system priority configured in the Eth-Trunk interface view takes effect for only the specified Eth-Trunk. If the **lACP m-lag priority** command is configured both in both the system view and Eth-Trunk interface view, the LACP M-LAG system priority configured in the Eth-Trunk view takes effect.
 - When multiple M-LAGs are configured on the device, different Eth-Trunks can use different LACP M-LAG system priorities. In this case, you need to set the LACP M-LAG system priority in the Eth-Trunk interface view.
 - 2) Run the **lACP m-lag system-id** *mac-address* command to set the LACP M-LAG system ID.

There is no default LACP M-LAG system ID in the Eth-Trunk interface view.

 - Eth-Trunks on both devices configured with M-LAG must use the same LACP M-LAG system ID.
 - The LACP M-LAG system ID configured in the system view takes effect for all Eth-Trunks. The LACP M-LAG system ID configured in the Eth-Trunk interface view takes effect for only the specified Eth-Trunk. If the **lACP m-lag system-id** command is configured both in both the system view and Eth-Trunk interface view, the LACP M-LAG system ID configured in the Eth-Trunk view takes effect.
 - When multiple M-LAGs are configured on the device, different Eth-Trunks can use different LACP M-LAG system IDs. In this case, you need to set the LACP M-LAG system ID in the Eth-Trunk interface view.

f. Run:

```
commit
```

The configuration is committed.

----End

(Optional) Configuring the Dual-Active Gateway

Prerequisites

The M-LAG member interface has been added to the corresponding VLAN.

Context

On a dual-homing IP network, both the M-LAG master and backup devices need to function as Layer 3 gateways. In this case, VLANIF interfaces corresponding to M-LAG member

interfaces must have the same IP address and MAC address. You can use the following methods:

- Create a VRRP group on VLANIF interfaces and configure the same virtual IP address and virtual MAC address for VLANIF interfaces corresponding to M-LAG member interfaces of M-LAG master and backup devices. M-LAG and VRRP are configured to implement dual-active gateway.
- Configure the same IP address and run the **mac-address** command to configure the same virtual MAC address for VLANIF interfaces corresponding to M-LAG member interfaces of M-LAG master and backup devices.

Procedure

- Configure VRRP to implement dual-active gateway.

a. Run:

```
system-view
```

The system view is displayed.

b. Run:

```
interface vlanif vlan-id
```

The VLANIF interface view is displayed.

c. Run:

```
ip address ip-address { mask | mask-length } [ sub ]
```

An IP address is configured for the VLANIF interface.

By default, no IP address is configured for an interface.

You must configure IP addresses on the same network segment for VLANIF interfaces corresponding to M-LAG member interfaces of M-LAG master and backup devices.

d. Run:

```
vrrp vrid virtual-router-id virtual-ip virtual-address
```

A VRRP group is created and a virtual IP address is assigned to the VRRP group.

By default, no VRRP group is created.

The M-LAG master and backup devices must be configured with the same VRID and virtual IP address of the VRRP group, and the virtual IP address of the VRRP group and IP address of the VLANIF interface must be on the same network segment.

e. (Optional) Run:

```
protocol up-delay-time time-value
```

The delay before the Layer 3 protocol status of an interface can go Up is set.

By default, the delay before the Layer 3 protocol status of a VLANIF interface can go Up is 1s. When there are many ARP entries, the delay is increased.

When the faulty device or peer-link recovers, many ARP entries need to be synchronized in a batch. You can configure the delay so that the protocol status of the interface go Up after ARP entries are synchronized. This prevents protocol packets from being discarded, reduces the packet loss during link recovery, and improves convergence performance.

f. Run:

```
commit
```

The configuration is committed.

- Configure an IP address and a MAC address for a VLANIF interface to implement dual-active gateway.

a. Run:

```
system-view
```

The system view is displayed.

b. Run:

```
interface vlanif vlan-id
```

The VLANIF interface view is displayed.

c. Run:

```
ip address ip-address { mask | mask-length } [ sub ]
```

An IP address is assigned to the VLANIF interface.

By default, no IP address is configured for an interface.

VLANIF interfaces corresponding to M-LAG member interfaces of M-LAG master and backup devices must be configured with the same IP address.

d. Run:

```
mac-address mac-address
```

A virtual MAC address is configured for the VLANIF interface.

By default, the MAC address of a VLANIF interface must be the same as the system MAC address.

VLANIF interfaces corresponding to M-LAG member interfaces of M-LAG master and backup devices must be configured with the same virtual MAC address.

e. (Optional) Run:

```
protocol up-delay-time time-value
```

The delay before the Layer 3 protocol status of an interface can go Up is set.

By default, the delay before the Layer 3 protocol status of a VLANIF interface can go Up is 1s. When there are many ARP entries, the delay is increased.

When the faulty device or peer-link recovers, many ARP entries need to be synchronized in a batch. You can configure the delay so that the protocol status of the interface go Up after ARP entries are synchronized. This prevents protocol packets from being discarded, reduces the packet loss during link recovery, and improves convergence performance.

f. Run:

```
commit
```

The configuration is committed.

----End

(Optional) Associating Uplink and Downlink Interfaces with a Monitor Link Group

Context

On dual-homing TRILL, VXLAN, and IP networks, an uplink fault may cause a failure to forward user-side traffic. Consequently, user-side traffic is discarded. To prevent this problem, associate uplink and downlink interfaces with the Monitor Link group.

As shown in **Figure 1-27**, when the uplink of SwitchA fails, user-side traffic that is forwarded by SwitchA will be discarded. To prevent this problem, associate uplink and downlink interfaces with the Monitor Link group on SwitchA. Then the uplink interface of SwitchA also enters the Down state and user-side traffic is not forwarded by SwitchA. That is, traffic is forwarded normally.

Figure 1-27 Uplink fails

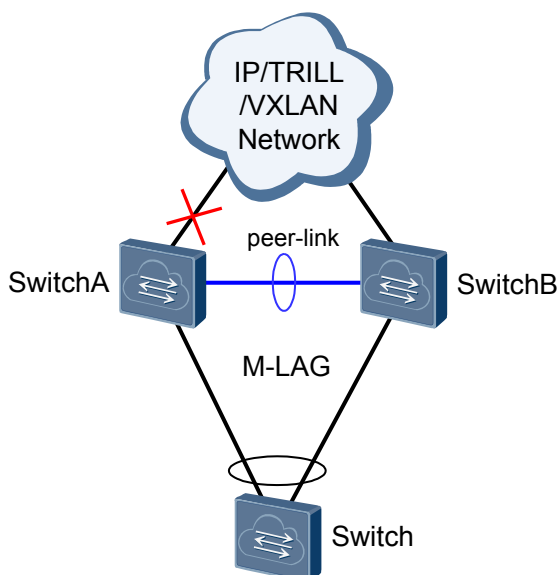

Procedure

Step 1 Run:

```
system-view
```

The system view is displayed.

Step 2 Run:

```
monitor-link group group-id
```

The Monitor Link group view is displayed.

The device supports a maximum of 24 Monitor Link groups.

Step 3 Run:

```
port interface-type interface-number { downlink [ downlink-id ] | uplink }
```

An interface is configured as an uplink or downlink interface of the Monitor Link group.

After a Monitor Link group is configured, the uplink interfaces are monitored in real time. When all uplink interfaces fail, all the downlink interfaces in the Monitor Link group are forcibly set to Error-Down state.

The device records the status of an interface as Error-Down when it detects that a fault occurs. The interface in Error-Down state cannot receive or send packets and the interface indicator is off.

Step 4 (Optional) Run:

```
timer recover-time recover-time
```

The wait to restore (WTR) time is set.

By default, revertive switching of a Monitor Link group is enabled and the WTR time is 3 seconds.

Step 5 Run:

```
commit
```

The configuration is committed.

---End

Checking the Configuration

- Run the **display monitor-link group** { all | *group-id* } command to check information about the Monitor Link group.

Follow-up Procedure

- To change the downlink interface status from Error-Down to Up, rectify the fault on the uplink interface. After the uplink interface becomes Up and the automatic switching time is reached, the downlink interfaces become Up.
- In some situations, for example, an optical module needs to be replaced, you may want to change the uplink status temporarily without affecting the downlink status. To save the trouble, run the **monitor-link disable** command. After this command is configured, Monitor Link does not change the downlink interface status based on the uplink status.

(Optional) Configuring an Interface in Error-Down State

Context

On a dual-homing TRILL network where M-LAG is deployed, when the peer-link fails but the heartbeat status is normal, the M-LAG interface on the backup device enters the Error-Down state. On a dual-homing Ethernet, VXLAN, or IP network where M-LAG is deployed, when the peer-link fails but the heartbeat status is normal, interfaces except the management interface, peer-link interface, and stack interface on the backup device all enter the Error-Down state. When the peer-link recovers, the M-LAG interface in Error-Down state becomes Up after 2 minutes by default, and the physical interfaces in Error-Down state are restored to be Up. In an SVF of fixed and modular switches, the physical interfaces in Error-Down state on a leaf switch are restored after 5 minutes by default.

The **m-lag unpaired-port suspend** command is configured on an interface of the backup device in the following situation:

When the peer-link fails but the heartbeat status is normal, only the interface where the **m-lag unpaired-port suspend** command is configured enters the Error-Down state in addition to the M-LAG interface in Error-Down state.

Procedure

Step 1 Run:

```
system-view
```

The system view is displayed.

Step 2 Run:

```
interface interface-type interface-number
```

The interface view is displayed.

Step 3 Run:

```
m-lag unpaired-port suspend
```

The interface is configured to enter the Error-Down state when the peer-link fails.

This command cannot be configured on the M-LAG interface. It is recommended that this command be configured on both the M-LAG master and backup devices.

Step 4 Run:

```
commit
```

The configuration is committed.

---End

Checking the Configuration

Procedure

- Run the **display dfs-group** *dfs-group-id* [**node** *node-id* **m-lag** [**brief**] | **peer-link**] command to check M-LAG information.

---End

Follow-up Procedure

After M-LAG is configured, if the peer-link fails but the heartbeat status is normal, some interfaces on the backup device will enter the Error-Down state. The device records the status of an interface as Error-Down when it detects that a fault occurs. The interface in Error-Down state cannot receive or send packets and the interface indicator is off. You can run the **display error-down recovery** command to check information about all interfaces in Error-Down state on the device.

- When M-LAG is used for dual-homing to a TRILL network and the peer-link fails but the heartbeat is normal, the M-LAG interface on the backup device will enter the error-down state. When the peer-link recovers, the physical interfaces change from error-down to Up after 2 minutes by default (the physical interface on a leaf switch in an SVF of modular and fixed switches changes from error-down to Up after 5 minutes by default).
- When M-LAG is used for dual-homing to an Ethernet, VXLAN network, or IP network and the peer-link fails but the heartbeat is normal, all physical interfaces except the management interface, peer-link interface, and stack interface on the backup device will

enter the error-down state. When the peer-link recovers, the M-LAG interface change from error-down to Up after 2 minutes by default (the physical interface on a leaf switch in an SVF of modular and fixed switches changes from error-down to Up after 5 minutes by default). Other physical interfaces go Up immediately by default.

When the interface enters the Error-Down state, locate the cause. You are not advised to manually restore the interface or run the **error-down auto-recovery cause m-lag interval interval-value** command in the system view to enable the interface to go Up automatically. Otherwise, packet loss or forwarding failure may occur. Exercise caution when you perform the preceding operation.

1.6.2 Configuring M-LAG Through V-STP (Recommended)

V-STP virtualizes the M-LAG master and backup devices enabled with STP into one device to perform STP calculation.

Configuring V-STP

Context

Virtual Spanning Tree Protocol (V-STP) is a Layer 2 topology management feature and virtualizes two STP-enabled devices into one device to perform STP calculation.

STP can detect the M-LAG master or backup status. After V-STP is enabled on the M-LAG master and backup devices and M-LAG master/backup negotiation is successful, two devices are virtualized into one device for port role calculation and fast convergence. STP needs to synchronize the bridge information and instance priority of the M-LAG master and backup devices. After M-LAG master/backup negotiation is successful, the backup device uses the bridge MAC address and instance priority that is synchronized from the master device for STP calculation and packet transmission. This ensures STP parameter calculation on the virtualized device.

V-STP can be only applicable to M-LAG networking. It can be used in multi-level M-LAG interconnection scenarios and scenarios where devices in the M-LAG function as non-root-bridges.

When configuring V-STP, ensure that the STP/RSTP timer settings on the two devices that constitute an M-LAG be the same. Otherwise, network flapping may occur.

Procedure

Step 1 Run:

```
system-view
```

The system view is displayed.

Step 2 Run:

```
stp mode { stp | rstp }
```

The switch is configured to work in STP or RSTP mode.

By default, the switch works in MSTP mode.

V-STP does not support the MSTP mode or multi-process.

Step 3 (Optional) Run:

```
stp priority priority
```

The STP priority of the switch is set.

By default, the STP priority of a switch is 32768.

To prevent STP network flapping caused by switch restart, VS restart, or DFS active/standby switchover and ensure switching performance, you are advised to set a low STP priority for the switch of which the DFS is in slave state.

Step 4 (Optional) Run:

```
stp bridge-address mac-address
```

The bridge MAC address used in spanning tree participation is configured.

By default, the switch's MAC address is the bridge MAC address of the switch that participates in spanning tree calculation.

To prevent STP network flapping caused by switch restart, VS restart, or DFS active/standby switchover and ensure switching performance, you are advised to set a larger bridge MAC address for the switch of which the DFS is in slave state when the M-LAG master and backup devices have the same priority.

Step 5 Run:

```
stp v-stp enable
```

V-STP is enabled on an M-LAG device.

By default, V-STP is disabled on an M-LAG device.

Step 6 Run:

```
commit
```

The configuration is committed.

----End

Configuring a DFS Group

Context

A Dynamic Fabric Service (DFS) group is used for device pairing. A DFS group needs to be bound to nicknames or IP addresses so that devices at both ends can exchange heartbeat packets. The bound nicknames or IP addresses are used for communication with the remote end. You can bind a DFS group to either a nickname or an IP address in the following situation:

- When a device is dual-homed to a TRILL network, a DFS group needs to be bound to a nickname. Ensure that the nickname has been configured.

On a Transparent Interconnection of Lots of Links (TRILL) dual-active network, you can configure a pseudo nickname for a DFS group. You need to configure the same pseudo nickname on two devices connected to a device on a dual-homing TRILL network. The remote device considers that one device connects to the TRILL network, and users therefore do not need to consider the network topology.

- When a device is dual-homed to PEs on an Ethernet, VXLAN, or IP network, DFS groups need to be bound to IP addresses. Ensure that IP addresses have been configured for Layer 3 interfaces on two PEs and the two PEs can communicate.

If the device connects to a VPN, you must specify the VPN instance bound to a DFS group. Ensure that the VPN instance has been created.

Procedure

Step 1 Run:

```
system-view
```

The system view is displayed.

Step 2 Run:

```
dfs-group dfs-group-id
```

A DFS group is created and its view is displayed, or the view of an existing DFS group is displayed.

Step 3 Run the following commands as required.

- When a device is dual-homed to a TRILL network, bind a DFS group to a nickname and configure a pseudo nickname.

a. Run:

```
source nickname nickname-value
```

The DFS group is bound to a nickname.

b. Run:

```
pseudo-nickname nickname-value1 [ priority priority ]
```

A pseudo nickname is configured for the DFS group.

- When a device is dual-homed to an Ethernet, VXLAN, or IP network, bind a DFS group to an IP address. Run either of the following commands.

- Run:

```
source ip ip-address [ vpn-instance vpn-instance-name ]
```

The DFS group is bound to an IPv4 address and a VPN instance.

- Run:

```
source ipv6 ipv6-address [ vpn-instance vpn-instance-name ]
```

The DFS group is bound to an IPv6 address and a VPN instance.

Step 4 (Optional) Run:

```
priority priority
```

The priority of the DFS group is set.

The priority of a DFS group is used for master/backup negotiation between two devices. A larger value indicates a higher priority of the device. The device with a higher priority is the master device.

If the priorities of two devices are the same, the device with a smaller MAC address is the master device.

By default, the priority of a DFS group is 100.

Step 5 (Optional) Run:

```
m-lag up-delay value
```

The delay for the M-LAG interface to report the Up event is set.

To ensure the performance of revertive switching, the default delay for the M-LAG interface to report the Up event is 120s in scenarios such as device or Peer-link failure.

Step 6 Run:

```
commit
```

The configuration is committed.

----End

Configuring an Interface as a Peer-link Interface

Context

A peer-link is a direct aggregated link between two devices configured with M-LAG. It is used to exchange protocol packets and transmit some traffic, and ensures normal running of M-LAG.

Prerequisites

The direct link between two devices configured with M-LAG has been configured as an aggregated link.

Procedure

Step 1 Run:

```
system-view
```

The system view is displayed.

Step 2 Run:

```
interface eth-trunk trunk-id
```

The Eth-Trunk interface view is displayed.

Step 3 Run:

```
mode { lacp-static | lacp-dynamic }
```

The Eth-Trunk is configured to work in LACP mode.

By default, an Eth-Trunk works in manual load balancing mode. To ensure M-LAG reliability, you are advised to configure the Eth-Trunk to work in LACP mode.

Step 4 Run:

```
stp enable
```

STP is enabled on the interface.

By default, STP is enabled on an interface.

Step 5 Run:

```
peer-link peer-link-id
```

The interface is configured as a peer-link interface.

By default, no interface is configured as a peer-link interface.

- An interface configured as a peer-link interface joins all VLANs by default.

- An interface configured as a peer-link interface cannot be configured with any service.
- If the ERPS control VLAN, TRILL carrier VLAN, or FCoE VLAN needs to be configured, perform **Step 6** to remove the peer-link interface from the control VLAN, carrier VLAN, or FCoE VLAN. Otherwise, the control VLAN, carrier VLAN, or FCoE VLAN cannot be configured.
- If the network-side VLANIF interface is configured, perform **Step 6** to remove the peer-link interface from the VLAN. Otherwise, heartbeat detection may take ineffective.

Step 6 (Optional) Run:

```
port vlan exclude { { vlan-id1 [ to vlan-id2 ] } &<1-10> }
```

The VLANs not allowed by the peer-link interface are specified.

By default, no allowed VLAN is specified on a peer-link interface.

Step 7 Run:

```
commit
```

The configuration is committed.

----End

Configuring an M-LAG Member Interface

Prerequisites

The links between a user-side device and two devices configured with M-LAG have been configured as aggregated links. To improve reliability, you are advised to configure link aggregation in LACP mode.

Procedure

- When the Eth-Trunk works in manual load balancing mode, perform the following operations.

a. Run:

```
system-view
```

The system view is displayed.

b. Run:

```
interface eth-trunk trunk-id
```

The Eth-Trunk interface view is displayed.

c. Run:

```
dfs-group dfs-group-id m-lag m-lag-id
```

The Eth-Trunk is bound to a DFS group, that is, the Eth-Trunk is configured as an M-LAG member interface.

 **NOTE**

The two devices configured with M-LAG must use the same M-LAG ID.

d. Run:

```
commit
```

The configuration is committed.

- When the Eth-Trunk works in LACP mode, perform the following operations.

- a. Run:

```
system-view
```

The system view is displayed.

- b. Run:

```
interface eth-trunk trunk-id
```

The Eth-Trunk interface view is displayed.

- c. Run:

```
mode { lacp-static | lacp-dynamic }
```

The Eth-Trunk is configured to work in LACP mode.

- d. Run:

```
dfs-group dfs-group-id m-lag m-lag-id
```

The Eth-Trunk is bound to a DFS group, that is, the Eth-Trunk is configured as an M-LAG member interface.

 **NOTE**

The two devices configured with M-LAG must use the same M-LAG ID.

- e. Set the LACP M-LAG system priority and ID.

- In the system view:

- 1) Run the **quit** command to exit from the Eth-Trunk interface view.
- 2) Run the **lacp m-lag priority priority** command to set the LACP M-LAG system priority.

The default LACP M-LAG system priority is 32768.

- The LACP M-LAG system priority is valid for the M-LAG composed of an Eth-Trunk in LACP mode, whereas the LACP system priority configured by the **lacp priority** command is valid for an Eth-Trunk in LACP mode.
- Eth-Trunks on both devices configured with M-LAG must use the same LACP M-LAG system priority.

- 3) Run the **lacp m-lag system-id mac-address** command to set the LACP M-LAG system ID.

By default, the LACP M-LAG system ID in the system view is the MAC address of the Ethernet interface on the MPU.

- The LACP M-LAG system ID is valid for the M-LAG composed of an Eth-Trunk in LACP mode, whereas the LACP system ID is valid for an Eth-Trunk in LACP mode. The default LACP M-LAG system ID is the MAC address of an Ethernet interface on the MPU and cannot be changed.
- Eth-Trunks on both devices configured with M-LAG must use the same LACP M-LAG system ID.

- In the Eth-Trunk interface view:

- 1) Run the **lacp m-lag priority priority** command to set the LACP M-LAG system priority.

There is no default LACP M-LAG system priority in the Eth-Trunk interface view.

- Eth-Trunks on both devices configured with M-LAG must use the same LACP M-LAG system priority.
 - The LACP M-LAG system priority configured in the system view takes effect for all Eth-Trunks. The LACP M-LAG system priority configured in the Eth-Trunk interface view takes effect for only the specified Eth-Trunk. If the **lACP m-lag priority** command is configured both in both the system view and Eth-Trunk interface view, the LACP M-LAG system priority configured in the Eth-Trunk view takes effect.
 - When multiple M-LAGs are configured on the device, different Eth-Trunks can use different LACP M-LAG system priorities. In this case, you need to set the LACP M-LAG system priority in the Eth-Trunk interface view.
- 2) Run the **lACP m-lag system-id mac-address** command to set the LACP M-LAG system ID.

There is no default LACP M-LAG system ID in the Eth-Trunk interface view.

- Eth-Trunks on both devices configured with M-LAG must use the same LACP M-LAG system ID.
- The LACP M-LAG system ID configured in the system view takes effect for all Eth-Trunks. The LACP M-LAG system ID configured in the Eth-Trunk interface view takes effect for only the specified Eth-Trunk. If the **lACP m-lag system-id** command is configured both in both the system view and Eth-Trunk interface view, the LACP M-LAG system ID configured in the Eth-Trunk view takes effect.
- When multiple M-LAGs are configured on the device, different Eth-Trunks can use different LACP M-LAG system IDs. In this case, you need to set the LACP M-LAG system ID in the Eth-Trunk interface view.

f. Run:

```
commit
```

The configuration is committed.

----End

(Optional) Configuring the Dual-Active Gateway

Prerequisites

The M-LAG member interface has been added to the corresponding VLAN.

Context

On a dual-homing IP network, both the M-LAG master and backup devices need to function as Layer 3 gateways. In this case, VLANIF interfaces corresponding to M-LAG member interfaces must have the same IP address and MAC address. You can use the following methods:

- Create a VRRP group on VLANIF interfaces and configure the same virtual IP address and virtual MAC address for VLANIF interfaces corresponding to M-LAG member

interfaces of M-LAG master and backup devices. M-LAG and VRRP are configured to implement dual-active gateway.

- Configure the same IP address and run the **mac-address** command to configure the same virtual MAC address for VLANIF interfaces corresponding to M-LAG member interfaces of M-LAG master and backup devices.

Procedure

- Configure VRRP to implement dual-active gateway.

- a. Run:

```
system-view
```

The system view is displayed.

- b. Run:

```
interface vlanif vlan-id
```

The VLANIF interface view is displayed.

- c. Run:

```
ip address ip-address { mask | mask-length } [ sub ]
```

An IP address is configured for the VLANIF interface.

By default, no IP address is configured for an interface.

You must configure IP addresses on the same network segment for VLANIF interfaces corresponding to M-LAG member interfaces of M-LAG master and backup devices.

- d. Run:

```
vrrp vrid virtual-router-id virtual-ip virtual-address
```

A VRRP group is created and a virtual IP address is assigned to the VRRP group.

By default, no VRRP group is created.

The M-LAG master and backup devices must be configured with the same VRID and virtual IP address of the VRRP group, and the virtual IP address of the VRRP group and IP address of the VLANIF interface must be on the same network segment.

- e. (Optional) Run:

```
protocol up-delay-time time-value
```

The delay before the Layer 3 protocol status of an interface can go Up is set.

By default, the delay before the Layer 3 protocol status of a VLANIF interface can go Up is 1s. When there are many ARP entries, the delay is increased.

When the faulty device or peer-link recovers, many ARP entries need to be synchronized in a batch. You can configure the delay so that the protocol status of the interface go Up after ARP entries are synchronized. This prevents protocol packets from being discarded, reduces the packet loss during link recovery, and improves convergence performance.

- f. Run:

```
commit
```

The configuration is committed.

- Configure an IP address and a MAC address for a VLANIF interface to implement dual-active gateway.
 - a. Run:

```
system-view
```

The system view is displayed.
 - b. Run:

```
interface vlanif vlan-id
```

The VLANIF interface view is displayed.
 - c. Run:

```
ip address ip-address { mask | mask-length } [ sub ]
```

An IP address is assigned to the VLANIF interface.
By default, no IP address is configured for an interface.
VLANIF interfaces corresponding to M-LAG member interfaces of M-LAG master and backup devices must be configured with the same IP address.
 - d. Run:

```
mac-address mac-address
```

A virtual MAC address is configured for the VLANIF interface.
By default, the MAC address of a VLANIF interface must be the same as the system MAC address.
VLANIF interfaces corresponding to M-LAG member interfaces of M-LAG master and backup devices must be configured with the same virtual MAC address.
 - e. (Optional) Run:

```
protocol up-delay-time time-value
```

The delay before the Layer 3 protocol status of an interface can go Up is set.
By default, the delay before the Layer 3 protocol status of a VLANIF interface can go Up is 1s. When there are many ARP entries, the delay is increased.
When the faulty device or peer-link recovers, many ARP entries need to be synchronized in a batch. You can configure the delay so that the protocol status of the interface go Up after ARP entries are synchronized. This prevents protocol packets from being discarded, reduces the packet loss during link recovery, and improves convergence performance.
 - f. Run:

```
commit
```

The configuration is committed.

----End

(Optional) Associating Uplink and Downlink Interfaces with a Monitor Link Group

Context

On dual-homing TRILL, VXLAN, and IP networks, an uplink fault may cause a failure to forward user-side traffic. Consequently, user-side traffic is discarded. To prevent this problem, associate uplink and downlink interfaces with the Monitor Link group.

As shown in **Figure 1-28**, when the uplink of SwitchA fails, user-side traffic that is forwarded by SwitchA will be discarded. To prevent this problem, associate uplink and downlink interfaces with the Monitor Link group on SwitchA. Then the uplink interface of SwitchA also enters the Down state and user-side traffic is not forwarded by SwitchA. That is, traffic is forwarded normally.

Figure 1-28 Uplink fails

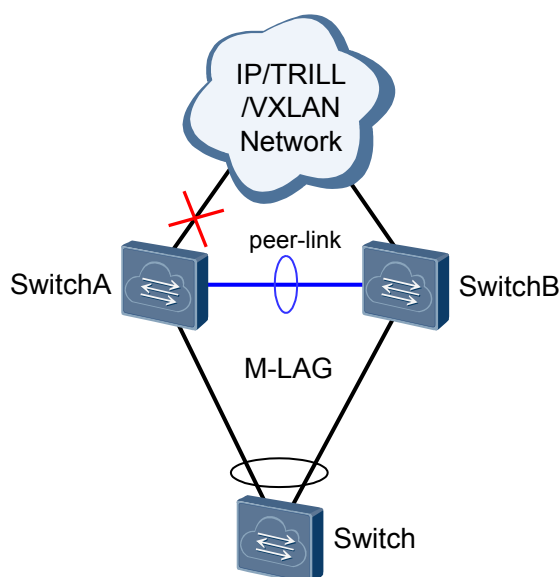

Procedure

Step 1 Run:

```
system-view
```

The system view is displayed.

Step 2 Run:

```
monitor-link group group-id
```

The Monitor Link group view is displayed.

The device supports a maximum of 24 Monitor Link groups.

Step 3 Run:

```
port interface-type interface-number { downlink [ downlink-id ] | uplink }
```

An interface is configured as an uplink or downlink interface of the Monitor Link group.

After a Monitor Link group is configured, the uplink interfaces are monitored in real time. When all uplink interfaces fail, all the downlink interfaces in the Monitor Link group are forcibly set to Error-Down state.

The device records the status of an interface as Error-Down when it detects that a fault occurs. The interface in Error-Down state cannot receive or send packets and the interface indicator is off.

Step 4 (Optional) Run:

```
timer recover-time recover-time
```

The wait to restore (WTR) time is set.

By default, revertive switching of a Monitor Link group is enabled and the WTR time is 3 seconds.

Step 5 Run:

```
commit
```

The configuration is committed.

---End

Checking the Configuration

- Run the **display monitor-link group** { all | *group-id* } command to check information about the Monitor Link group.

Follow-up Procedure

- To change the downlink interface status from Error-Down to Up, rectify the fault on the uplink interface. After the uplink interface becomes Up and the automatic switching time is reached, the downlink interfaces become Up.
- In some situations, for example, an optical module needs to be replaced, you may want to change the uplink status temporarily without affecting the downlink status. To save the trouble, run the **monitor-link disable** command. After this command is configured, Monitor Link does not change the downlink interface status based on the uplink status.

(Optional) Configuring an Interface in Error-Down State

Context

On a dual-homing TRILL network where M-LAG is deployed, when the peer-link fails but the heartbeat status is normal, the M-LAG interface on the backup device enters the Error-Down state. On a dual-homing Ethernet, VXLAN, or IP network where M-LAG is deployed, when the peer-link fails but the heartbeat status is normal, interfaces except the management interface, peer-link interface, and stack interface on the backup device all enter the Error-Down state. When the peer-link recovers, the M-LAG interface in Error-Down state becomes Up after 2 minutes by default, and the physical interfaces in Error-Down state are restored to be Up. In an SVF of fixed and modular switches, the physical interfaces in Error-Down state on a leaf switch are restored after 5 minutes by default.

The **m-lag unpaired-port suspend** command is configured on an interface of the backup device in the following situation:

When the peer-link fails but the heartbeat status is normal, only the interface where the **m-lag unpaired-port suspend** command is configured enters the Error-Down state in addition to the M-LAG interface in Error-Down state.

Procedure

Step 1 Run:

```
system-view
```

The system view is displayed.

Step 2 Run:

```
interface interface-type interface-number
```

The interface view is displayed.

Step 3 Run:

```
m-lag unpaired-port suspend
```

The interface is configured to enter the Error-Down state when the peer-link fails.

This command cannot be configured on the M-LAG interface. It is recommended that this command be configured on both the M-LAG master and backup devices.

Step 4 Run:

```
commit
```

The configuration is committed.

----End

Checking the Configuration

Procedure

- Run the **display dfs-group dfs-group-id [node node-id m-lag [brief] | peer-link]** command to check M-LAG information.
- Run the **display stp v-stp** command to check the V-STP status and statistics.

----End

Follow-up Procedure

After M-LAG is configured, if the peer-link fails but the heartbeat status is normal, some interfaces on the backup device will enter the Error-Down state. The device records the status of an interface as Error-Down when it detects that a fault occurs. The interface in Error-Down state cannot receive or send packets and the interface indicator is off. You can run the **display error-down recovery** command to check information about all interfaces in Error-Down state on the device.

- When M-LAG is used for dual-homing to a TRILL network and the peer-link fails but the heartbeat is normal, the M-LAG interface on the backup device will enter the error-down state. When the peer-link recovers, the physical interfaces change from error-down to Up after 2 minutes by default (the physical interface on a leaf switch in an SVF of modular and fixed switches changes from error-down to Up after 5 minutes by default).
- When M-LAG is used for dual-homing to an Ethernet, VXLAN network, or IP network and the peer-link fails but the heartbeat is normal, all physical interfaces except the

management interface, peer-link interface, and stack interface on the backup device will enter the error-down state. When the peer-link recovers, the M-LAG interface change from error-down to Up after 2 minutes by default (the physical interface on a leaf switch in an SVF of modular and fixed switches changes from error-down to Up after 5 minutes by default). Other physical interfaces go Up immediately by default.

When the interface enters the Error-Down state, locate the cause. You are not advised to manually restore the interface or run the **error-down auto-recovery cause m-lag interval interval-value** command in the system view to enable the interface to go Up automatically. Otherwise, packet loss or forwarding failure may occur. Exercise caution when you perform the preceding operation.

1.7 Configuration Examples

1.7.1 Example for Deploying M-LAG to Connect the Device to an Ethernet Network in Dual-Homing Mode Through the Root Bridge

Networking Requirements

As shown in [Figure 1-29](#), a server is dual-homed to an Ethernet network through M-LAG. The customer requires high service reliability. Link aggregation between the server and devices only achieves link-level reliability, and a fault on a device may cause service interruption. M-LAG can be configured. When devices work properly, links load balance traffic and a fault of any device does not affect services. High service reliability is therefore ensured. On an Ethernet network, the blocked interface cannot transmit heartbeat packets of M-LAG master and backup devices; therefore, a DFS group is configured and bound to the IP address of the management interface to ensure that heartbeat packets of M-LAG master and backup devices can be transmitted normally.

Figure 1-29 Networking for dual homing the M-LAG to a common Ethernet network

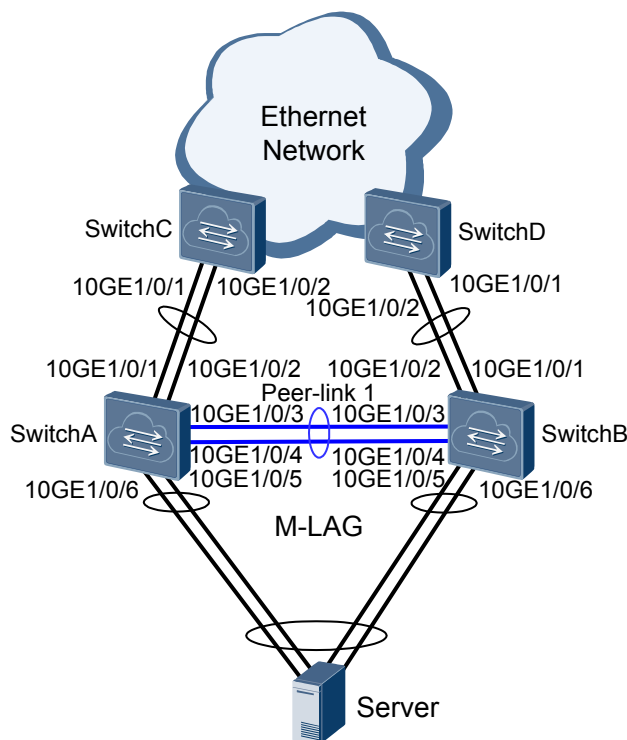

Configuration Roadmap

1. Configure SwitchA and SwitchB as the root bridge and configure the same bridge ID to ensure that M-LAG master and backup devices are used as root bridges.
2. Configure IP addresses for management interfaces on SwitchA and SwitchB to ensure Layer 3 connectivity and transmission of heartbeat packets of M-LAG master and backup devices.
3. Configure M-LAG on SwitchA and SwitchB so that the server is dual-homed to SwitchA and SwitchB.
4. Create VLANIF interfaces on SwitchC and SwitchD and configure IP addresses for the VLANIF interfaces, and create VRRP groups on the VLANIF interfaces and configure VRRP groups as gateways of M-LAG master and backup devices.

Procedure

Step 1 Configure SwitchA and SwitchB as root bridges and configure the same bridge ID for them.

NOTE

If the two devices that constitute an M-LAG connect to downstream switching devices, you must configure root protection.

Configure SwitchA.

```
<HUAWEI> system-view
[~HUAWEI] sysname SwitchA
[*HUAWEI] commit
[~SwitchA] stp root primary
[*SwitchA] stp bridge-address 39-39-39
[*SwitchA] interface eth-trunk 1
[*SwitchA-Eth-Trunk1] trunkport 10ge 1/0/5
```

```
[*SwitchA-Eth-Trunk1] trunkport 10ge 1/0/6
[*SwitchA-Eth-Trunk1] stp edged-port enable
[*SwitchA-Eth-Trunk1] commit
[~SwitchA-Eth-Trunk1] quit
```

Configure SwitchB.

```
<HUAWEI> system-view
[~HUAWEI] sysname SwitchB
[*HUAWEI] commit
[~SwitchB] stp root primary
[*SwitchB] stp bridge-address 39-39-39
[*SwitchB] interface eth-trunk 1
[*SwitchB-Eth-Trunk1] trunkport 10ge 1/0/5
[*SwitchB-Eth-Trunk1] trunkport 10ge 1/0/6
[*SwitchB-Eth-Trunk1] stp edged-port enable
[*SwitchB-Eth-Trunk1] commit
[~SwitchB-Eth-Trunk1] quit
```

Step 2 Configure IP addresses for management interfaces on SwitchA and SwitchB.

Configure SwitchA.

```
[~SwitchA] interface meth 0/0/0
[*SwitchA-Meth0/0/0] ip address 10.1.1.1 24
[*SwitchA-Meth0/0/0] quit
[*SwitchA] commit
```

Configure SwitchB.

```
[~SwitchB] interface meth 0/0/0
[*SwitchB-Meth0/0/0] ip address 10.1.1.2 24
[*SwitchB-Meth0/0/0] quit
[*SwitchB] commit
```

Step 3 Create DFS groups and bind IP addresses of management interfaces to DFS groups on SwitchA and SwitchB.

Configure IP addresses for management interfaces on SwitchA and SwitchB to ensure Layer 3 connectivity.

Configure SwitchA.

```
[~SwitchA] dfs-group 1
[*SwitchA-dfs-group-1] source ip 10.1.1.1
[*SwitchA-dfs-group-1] priority 150
[*SwitchA-dfs-group-1] quit
[*SwitchA] commit
```

Configure SwitchB.

```
[~SwitchB] dfs-group 1
[*SwitchB-dfs-group-1] source ip 10.1.1.2
[*SwitchB-dfs-group-1] priority 120
[*SwitchB-dfs-group-1] quit
[*SwitchB] commit
```

Step 4 Configure the link between SwitchA and SwitchB as a peer-link.

Configure SwitchA.

```
[~SwitchA] interface eth-trunk 0
[*SwitchA-Eth-Trunk0] trunkport 10ge 1/0/3
[*SwitchA-Eth-Trunk0] trunkport 10ge 1/0/4
[*SwitchA-Eth-Trunk0] undo stp enable
[*SwitchA-Eth-Trunk0] mode lacp-static
[*SwitchA-Eth-Trunk0] peer-link 1
[*SwitchA-Eth-Trunk0] quit
[*SwitchA] commit
```

Configure SwitchB.

```
[~SwitchB] interface eth-trunk 0
[*SwitchB-Eth-Trunk0] trunkport 10ge 1/0/3
[*SwitchB-Eth-Trunk0] trunkport 10ge 1/0/4
[*SwitchB-Eth-Trunk0] undo stp enable
[*SwitchB-Eth-Trunk0] mode lacp-static
[*SwitchB-Eth-Trunk0] peer-link 1
[*SwitchB-Eth-Trunk0] quit
[*SwitchB] commit
```

Step 5 Add Eth-Trunks that connect SwitchA and SwitchB to servers to VLAN 11 and bind the Eth-Trunks to DFS groups.

The uplink interface of the server connected to the switch needs to be bound to an aggregation link, and the link aggregation modes on the server and switch must be consistent.

Configure SwitchA.

```
[~SwitchA] vlan batch 11
[*SwitchA] interface eth-trunk 1
[*SwitchA-Eth-Trunk1] mode lacp-dynamic
[*SwitchA-Eth-Trunk1] port link-type access
[*SwitchA-Eth-Trunk1] port default vlan 11
[*SwitchA-Eth-Trunk1] dfs-group 1 m-lag 1
[*SwitchA-Eth-Trunk1] quit
[*SwitchA] lacp m-lag priority 10
[*SwitchA] lacp m-lag system-id 00e0-fc00-0000
[*SwitchA] commit
```

Configure SwitchB.

```
[~SwitchB] vlan batch 11
[*SwitchB] interface eth-trunk 1
[*SwitchB-Eth-Trunk1] mode lacp-dynamic
[*SwitchB-Eth-Trunk1] port link-type access
[*SwitchB-Eth-Trunk1] port default vlan 11
[*SwitchB-Eth-Trunk1] dfs-group 1 m-lag 1
[*SwitchB-Eth-Trunk1] quit
[*SwitchB] lacp m-lag priority 10
[*SwitchB] lacp m-lag system-id 00e0-fc00-0000
[*SwitchB] commit
```

Step 6 Configure the links between SwitchA and SwitchC and between SwitchB and SwitchD as aggregated links, and configure interface types and allowed VLANs.

Configure SwitchA.

```
[~SwitchA] interface eth-trunk 2
[*SwitchA-Eth-Trunk2] mode lacp-static
[*SwitchA-Eth-Trunk2] port link-type trunk
[*SwitchA-Eth-Trunk2] port trunk allow-pass vlan 11
[*SwitchA-Eth-Trunk2] trunkport 10ge 1/0/1
[*SwitchA-Eth-Trunk2] trunkport 10ge 1/0/2
[*SwitchA-Eth-Trunk2] quit
[*SwitchA] commit
```

Configure SwitchB.

```
[~SwitchB] interface eth-trunk 2
[*SwitchB-Eth-Trunk2] mode lacp-static
[*SwitchB-Eth-Trunk2] port link-type trunk
[*SwitchB-Eth-Trunk2] port trunk allow-pass vlan 11
[*SwitchB-Eth-Trunk2] trunkport 10ge 1/0/1
[*SwitchB-Eth-Trunk2] trunkport 10ge 1/0/2
[*SwitchB-Eth-Trunk2] quit
[*SwitchB] commit
```

Configure SwitchC.

```
<HUAWEI> system-view
[~HUAWEI] sysname SwitchC
[*HUAWEI] commit
[~SwitchC] vlan batch 11
[*SwitchC] interface eth-trunk 2
[*SwitchC-Eth-Trunk2] mode lacp-static
[*SwitchC-Eth-Trunk2] port link-type trunk
[*SwitchC-Eth-Trunk2] port trunk allow-pass vlan 11
[*SwitchC-Eth-Trunk2] trunkport 10ge 1/0/1
[*SwitchC-Eth-Trunk2] trunkport 10ge 1/0/2
[*SwitchC-Eth-Trunk2] quit
[*SwitchC] commit
```

Configure SwitchD.

```
<HUAWEI> system-view
[~HUAWEI] sysname SwitchD
[*HUAWEI] commit
[~SwitchD] vlan batch 11
[*SwitchD] interface eth-trunk 2
[*SwitchD-Eth-Trunk2] mode lacp-static
[*SwitchD-Eth-Trunk2] port link-type trunk
[*SwitchD-Eth-Trunk2] port trunk allow-pass vlan 11
[*SwitchD-Eth-Trunk2] trunkport 10ge 1/0/1
[*SwitchD-Eth-Trunk2] trunkport 10ge 1/0/2
[*SwitchD-Eth-Trunk2] quit
[*SwitchD] commit
```

Step 7 Create VLANIF interfaces on SwitchC and SwitchD and configure IP addresses for the VLANIF interfaces, and create VRRP groups on the VLANIF interfaces.

Configure VRRP group 1 on SwitchC and set the priority of SwitchC to 120.

```
[~SwitchC] interface vlanif 11
[*SwitchC-Vlanif11] ip address 10.2.1.1 24
[*SwitchC-Vlanif11] vrrp vrid 1 virtual-ip 10.2.1.111
[*SwitchC-Vlanif11] vrrp vrid 1 priority 120
[*SwitchC-Vlanif11] quit
[*SwitchC] commit
```

Configure VRRP group 1 on SwitchD. SwitchD uses default priority 100.

```
[~SwitchD] interface vlanif 11
[*SwitchD-Vlanif11] ip address 10.2.1.2 24
[*SwitchD-Vlanif11] vrrp vrid 1 virtual-ip 10.2.1.111
[*SwitchD-Vlanif11] quit
[*SwitchD] commit
```

Step 8 Verify the configuration.

- Run the **display dfs-group** command to check M-LAG information.

Check information about the M-LAG with DFS group 1.

```
[~SwitchA] display dfs-group 1 m-lag
*                : Local node
Heart beat state : OK
Node 1 *
  Dfs-Group ID   : 1
  Priority        : 150
  Address         : ip address 10.1.1.1
  State          : Master
  Causation      : -
  System ID      : 0025-9e95-7c31
  SysName        : SwitchA
  Version        : V100R006C00
  Device Type    : CE6850EI
Node 2
  Dfs-Group ID   : 1
  Priority        : 120
  Address         : ip address 10.1.1.2
```



```
State      : Backup
Causation  : -
System ID  : 0025-9e95-7c11
SysName    : SwitchB
Version    : V100R006C00
Device Type : CE6850EI
```

Check M-LAG information on SwitchA.

```
[~SwitchA] display dfs-group 1 node 1 m-lag brief
* - Local node

M-Lag ID   Interface   Port State   Status
-----
1          Eth-Trunk 1   Up           active(*)-active
```

Check M-LAG information on SwitchB.

```
[~SwitchA] display dfs-group 1 node 2 m-lag brief
* - Local node

M-Lag ID   Interface   Port State   Status
-----
1          Eth-Trunk 1   Up           active-active(*)
```

In the preceding information, the value of **Heart beat state** is **OK**, indicating that the heartbeat is normal. SwitchA is used as Node 1, its priority is 150, and its status is **Master**. SwitchB is used as Node 2, its priority is 120, and its status is **Backup**. The value of **Causation** is -, and the values of **Port State** of Node 1 and Node 2 are both **Up**, and the M-LAG status of Node 1 and Node 2 is both **active**, indicating that the M-LAG configuration is correct.

- Run the **display vrrp** command on SwitchC and SwitchD. You can see that SwitchC is in Master state and SwitchD is in Backup state.

```
[~SwitchC] display vrrp verbose
Vlanif11 | Virtual Router 1
State      : Master
Virtual IP : 10.2.1.111
Master IP  : 10.2.1.1
PriorityRun : 120
PriorityConfig : 120
MasterPriority : 120
Preempt    : YES   Delay Time : 0s   Remain : --
TimerRun   :
1s
TimerConfig : 1s
Auth Type  :
NONE
Virtual MAC :
0000-5e00-0101
Check TTL  :
YES
Config Type : Normal
Create Time : 2015-01-30
11:39:18
Last Change Time : 2015-02-04 11:38:58
[~SwitchD] display vrrp verbose
Vlanif11 | Virtual Router 1
State      : Backup
Virtual IP : 10.2.1.111
Master IP  : 10.2.1.1
PriorityRun : 100
PriorityConfig : 100
MasterPriority : 120
Preempt    : YES   Delay Time : 0s   Remain : --
TimerRun   : 1s
TimerConfig : 1s
Auth Type  : NONE
Virtual MAC : 0000-5e00-0101
Check TTL  : YES
Config Type : Normal
```

```
Create Time      : 2015-01-30 11:39:18  
Last Change Time : 2015-02-04 11:38:58
```

----End

Configuration Files

- SwitchA configuration file

```
#  
sysname SwitchA  
#  
dfs-group 1  
  priority 150  
  source ip 10.1.1.1  
#  
vlan batch 11  
#  
stp bridge-address 0039-0039-0039  
stp instance 0 root primary  
#  
lacp m-lag system-id 00e0-  
fc00-0000  
  
lacp m-lag priority  
10  
#  
interface MEth0/0/0  
  ip address 10.1.1.1 255.255.255.0  
#  
interface Eth-Trunk0  
  stp disable  
  mode lacp-static  
  peer-link 1  
#  
interface Eth-Trunk1  
  port default vlan 11  
  stp edged-port enable  
  mode lacp-dynamic  
  dfs-group 1 m-lag 1  
#  
interface Eth-Trunk2  
  port link-type trunk  
  port trunk allow-pass vlan 11  
  mode lacp-static  
#  
interface 10GE1/0/1  
  eth-trunk 2  
#  
interface 10GE1/0/2  
  eth-trunk 2  
#  
interface 10GE1/0/3  
  eth-trunk 0  
#  
interface 10GE1/0/4  
  eth-trunk 0  
#  
interface 10GE1/0/5  
  eth-trunk 1  
#  
interface 10GE1/0/6  
  eth-trunk 1  
#  
return
```

- SwitchB configuration file

```
#  
sysname SwitchB
```

```
#
dfs-group 1
  priority 120
  source ip 10.1.1.2
#
vlan batch 11
#
stp bridge-address 0039-0039-0039
stp instance 0 root primary
#

lacp m-lag system-id 00e0-
fc00-0000

lacp m-lag priority
10
#
interface MEth0/0/0
  ip address 10.1.1.2 255.255.255.0
#
interface Eth-Trunk0
  stp disable
  mode lacp-static
  peer-link 1
#
interface Eth-Trunk1
  port default vlan 11
  stp edged-port enable
  mode lacp-dynamic
  dfs-group 1 m-lag 1
#
interface Eth-Trunk2
  port link-type trunk
  port trunk allow-pass vlan 11
  mode lacp-static
#
interface 10GE1/0/1
  eth-trunk 2
#
interface 10GE1/0/2
  eth-trunk 2
#
interface 10GE1/0/3
  eth-trunk 0
#
interface 10GE1/0/4
  eth-trunk 0
#
interface 10GE1/0/5
  eth-trunk 1
#
interface 10GE1/0/6
  eth-trunk 1
#
return
```

- SwitchC configuration file

```
#
sysname SwitchC
#
vlan batch 11
#
interface Vlanif11
  ip address 10.2.1.1 255.255.255.0
  vrrp vrid 1 virtual-ip 10.2.1.111
  vrrp vrid 1 priority 120
#
interface Eth-Trunk2
  port link-type trunk
  port trunk allow-pass vlan 11
```

```
mode lacp-static
#
interface 10GE1/0/1
eth-trunk 2
#
interface 10GE1/0/2
eth-trunk 2
#
return
```

- SwitchD configuration file

```
#
sysname SwitchD
#
vlan batch 11
#
interface Vlanif11
ip address 10.2.1.2 255.255.255.0
vrrp vrid 1 virtual-ip 10.2.1.111
#
interface Eth-Trunk2
port link-type trunk
port trunk allow-pass vlan 11
mode lacp-static
#
interface 10GE1/0/1
eth-trunk 2
#
interface 10GE1/0/2
eth-trunk 2
#
return
```

1.7.2 Example for Deploying M-LAG to Connect the Device to an Ethernet Network in Dual-Homing Mode Through the Root Bridge Mode and a Heartbeat Line

Networking Requirements

As shown in [Figure 1-30](#), a server is dual-homed to an Ethernet network through M-LAG. The customer requires high service reliability. Link aggregation between the server and devices only achieves link-level reliability, and a fault on a device may cause service interruption. M-LAG can be configured. When devices work properly, links load balance traffic and a fault of any device does not affect services. High service reliability is therefore ensured. On an Ethernet network, the blocked interface cannot transmit heartbeat packets of M-LAG master and backup devices. A heartbeat line between M-LAG master and backup devices is added to ensure that heartbeat packets can be transmitted normally.

Figure 1-30 Networking for dual homing the M-LAG to a common Ethernet network

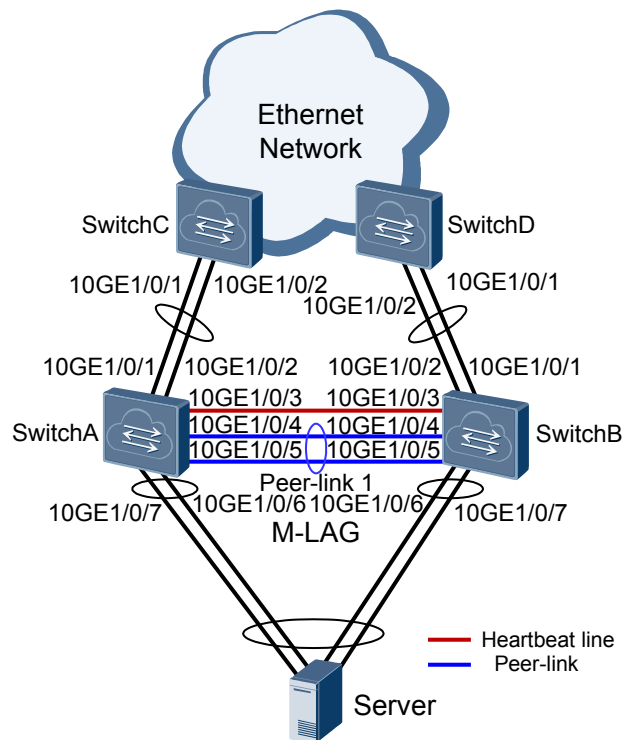

Configuration Roadmap

1. Configure SwitchA and SwitchB as the root bridge and configure the same bridge ID to ensure that M-LAG master and backup devices are used as root bridges.
2. Configure IP addresses for main interfaces on SwitchA and SwitchB to ensure Layer 3 connectivity and transmission of heartbeat packets of M-LAG master and backup devices.
3. Configure M-LAG on SwitchA and SwitchB so that the server is dual-homed to SwitchA and SwitchB.
4. Create VLANIF interfaces on SwitchC and SwitchD and configure IP addresses for the VLANIF interfaces, and create VRRP groups on the VLANIF interfaces and configure VRRP groups as gateways of M-LAG master and backup devices.

Procedure

- Step 1** Configure SwitchA and SwitchB as root bridges and configure the same bridge ID for them.

NOTE

If the two devices that constitute an M-LAG connect to downstream switching devices, you must configure root protection.

Configure SwitchA.

```
<HUAWEI> system-view
[~HUAWEI] sysname SwitchA
[*HUAWEI] commit
[~SwitchA] stp root primary
[*SwitchA] stp bridge-address 39-39-39
[*SwitchA] interface eth-trunk 1
[*SwitchA-Eth-Trunk1] trunkport 10ge 1/0/6
```

```
[*SwitchA-Eth-Trunk1] trunkport 10ge 1/0/7
[*SwitchA-Eth-Trunk1] stp edged-port enable
[*SwitchA-Eth-Trunk1] commit
[~SwitchA-Eth-Trunk1] quit
```

Configure SwitchB.

```
<HUAWEI> system-view
[~HUAWEI] sysname SwitchB
[*HUAWEI] commit
[~SwitchB] stp root primary
[*SwitchB] stp bridge-address 39-39-39
[*SwitchB] interface eth-trunk 1
[*SwitchB-Eth-Trunk1] trunkport 10ge 1/0/6
[*SwitchB-Eth-Trunk1] trunkport 10ge 1/0/7
[*SwitchB-Eth-Trunk1] stp edged-port enable
[*SwitchB-Eth-Trunk1] commit
[~SwitchB-Eth-Trunk1] quit
```

Step 2 Configure IP addresses for Layer 3 main interfaces on SwitchA and SwitchB.

Configure SwitchA.

```
[~SwitchA] interface 10ge 1/0/3
[~SwitchA-10GE1/0/3] undo portswitch
[*SwitchA-10GE1/0/3] ip address 10.1.1.1 24
[*SwitchA-10GE1/0/3] quit
[*SwitchA] commit
```

Configure SwitchB.

```
[~SwitchB] interface 10ge 1/0/3
[~SwitchB-10GE1/0/3] undo portswitch
[*SwitchB-10GE1/0/3] ip address 10.1.1.2 24
[*SwitchB-10GE1/0/3] quit
[*SwitchB] commit
```

Step 3 Create DFS groups and bind IP addresses of Layer 3 main interfaces to DFS groups on SwitchA and SwitchB.

NOTE

It is recommended that DFS groups be bound to Layer 3 main interfaces. If DFS groups are bound to VLANIF interfaces, ensure that VLANs at the access side are not allowed.

Configure SwitchA.

```
[~SwitchA] dfs-group 1
[*SwitchA-dfs-group-1] source ip 10.1.1.1
[*SwitchA-dfs-group-1] priority 150
[*SwitchA-dfs-group-1] quit
[*SwitchA] commit
```

Configure SwitchB.

```
[~SwitchB] dfs-group 1
[*SwitchB-dfs-group-1] source ip 10.1.1.2
[*SwitchB-dfs-group-1] priority 120
[*SwitchB-dfs-group-1] quit
[*SwitchB] commit
```

Step 4 Configure the link between SwitchA and SwitchB as a peer-link.

Configure SwitchA.

```
[~SwitchA] interface eth-trunk 0
[*SwitchA-Eth-Trunk0] trunkport 10ge 1/0/4
[*SwitchA-Eth-Trunk0] trunkport 10ge 1/0/5
[*SwitchA-Eth-Trunk0] undo stp enable
[*SwitchA-Eth-Trunk0] mode lacp-static
```

```
[*SwitchA-Eth-Trunk0] peer-link 1
[*SwitchA-Eth-Trunk0] quit
[*SwitchA] commit
```

Configure SwitchB.

```
[~SwitchB] interface eth-trunk 0
[*SwitchB-Eth-Trunk0] trunkport 10ge 1/0/4
[*SwitchB-Eth-Trunk0] trunkport 10ge 1/0/5
[*SwitchB-Eth-Trunk0] undo stp enable
[*SwitchB-Eth-Trunk0] mode lacp-static
[*SwitchB-Eth-Trunk0] peer-link 1
[*SwitchB-Eth-Trunk0] quit
[*SwitchB] commit
```

- Step 5** Add Eth-Trunks that connect SwitchA and SwitchB to servers to VLAN 11 and bind the Eth-Trunks to DFS groups.

The uplink interface of the server connected to the switch needs to be bound to an aggregation link, and the link aggregation modes on the server and switch must be consistent.

Configure SwitchA.

```
[~SwitchA] vlan batch 11
[*SwitchA] interface eth-trunk 1
[*SwitchA-Eth-Trunk1] mode lacp-dynamic
[*SwitchA-Eth-Trunk1] port link-type access
[*SwitchA-Eth-Trunk1] port default vlan 11
[*SwitchA-Eth-Trunk1] dfs-group 1 m-lag 1
[*SwitchA-Eth-Trunk1] quit
[*SwitchA] lacp m-lag priority 10
[*SwitchA] lacp m-lag system-id 00e0-fc00-0000
[*SwitchA] commit
```

Configure SwitchB.

```
[~SwitchB] vlan batch 11
[*SwitchB] interface eth-trunk 1
[*SwitchB-Eth-Trunk1] mode lacp-dynamic
[*SwitchB-Eth-Trunk1] port link-type access
[*SwitchB-Eth-Trunk1] port default vlan 11
[*SwitchB-Eth-Trunk1] dfs-group 1 m-lag 1
[*SwitchB-Eth-Trunk1] quit
[*SwitchB] lacp m-lag priority 10
[*SwitchB] lacp m-lag system-id 00e0-fc00-0000
[*SwitchB] commit
```

- Step 6** Configure the links between SwitchA and SwitchC and between SwitchB and SwitchD as aggregated links, and configure interface types and allowed VLANs.

Configure SwitchA.

```
[~SwitchA] interface eth-trunk 2
[*SwitchA-Eth-Trunk2] mode lacp-static
[*SwitchA-Eth-Trunk2] port link-type trunk
[*SwitchA-Eth-Trunk2] port trunk allow-pass vlan 11
[*SwitchA-Eth-Trunk2] trunkport 10ge 1/0/1
[*SwitchA-Eth-Trunk2] trunkport 10ge 1/0/2
[*SwitchA-Eth-Trunk2] quit
[*SwitchA] commit
```

Configure SwitchB.

```
[~SwitchB] interface eth-trunk 2
[*SwitchB-Eth-Trunk2] mode lacp-static
[*SwitchB-Eth-Trunk2] port link-type trunk
[*SwitchB-Eth-Trunk2] port trunk allow-pass vlan 11
[*SwitchB-Eth-Trunk2] trunkport 10ge 1/0/1
[*SwitchB-Eth-Trunk2] trunkport 10ge 1/0/2
```

```
[*SwitchB-Eth-Trunk2] quit
[*SwitchB] commit
```

Configure SwitchC.

```
<HUAWEI> system-view
[~HUAWEI] sysname SwitchC
[*HUAWEI] commit
[~SwitchC] vlan batch 11
[*SwitchC] interface eth-trunk 2
[*SwitchC-Eth-Trunk2] mode lacp-static
[*SwitchC-Eth-Trunk2] port link-type trunk
[*SwitchC-Eth-Trunk2] port trunk allow-pass vlan 11
[*SwitchC-Eth-Trunk2] trunkport 10ge 1/0/1
[*SwitchC-Eth-Trunk2] trunkport 10ge 1/0/2
[*SwitchC-Eth-Trunk2] quit
[*SwitchC] commit
```

Configure SwitchD.

```
<HUAWEI> system-view
[~HUAWEI] sysname SwitchD
[*HUAWEI] commit
[~SwitchD] vlan batch 11
[*SwitchD] interface eth-trunk 2
[*SwitchD-Eth-Trunk2] mode lacp-static
[*SwitchD-Eth-Trunk2] port link-type trunk
[*SwitchD-Eth-Trunk2] port trunk allow-pass vlan 11
[*SwitchD-Eth-Trunk2] trunkport 10ge 1/0/1
[*SwitchD-Eth-Trunk2] trunkport 10ge 1/0/2
[*SwitchD-Eth-Trunk2] quit
[*SwitchD] commit
```

Step 7 Create VLANIF interfaces on SwitchC and SwitchD and configure IP addresses for the VLANIF interfaces, and create VRRP groups on the VLANIF interfaces.

Configure VRRP group 1 on SwitchC and set the priority of SwitchC to 120.

```
[~SwitchC] interface vlanif 11
[*SwitchC-Vlanif11] ip address 10.2.1.1 24
[*SwitchC-Vlanif11] vrrp vrid 1 virtual-ip 10.2.1.111
[*SwitchC-Vlanif11] vrrp vrid 1 priority 120
[*SwitchC-Vlanif11] quit
[*SwitchC] commit
```

Configure VRRP group 1 on SwitchD. SwitchD uses default priority 100.

```
[~SwitchD] interface vlanif 11
[*SwitchD-Vlanif11] ip address 10.2.1.2 24
[*SwitchD-Vlanif11] vrrp vrid 1 virtual-ip 10.2.1.111
[*SwitchD-Vlanif11] quit
[*SwitchD] commit
```

Step 8 Verify the configuration.

- Run the **display dfs-group** command to check M-LAG information.

Check information about the M-LAG with DFS group 1.

```
[~SwitchA] display dfs-group 1 m-lag
*          : Local node
Heart beat state : OK
Node 1 *
Dfs-Group ID   : 1
Priority       : 150
Address        : ip address 10.1.1.1
State         : Master
Causation      : -
System ID     : 0025-9e95-7c31
SysName       : SwitchA
Version       : V100R006C00
```



```

Device Type      : CE6850EI
Node 2
Dfs-Group ID    : 1
Priority         : 120
Address         : ip address 10.1.1.2
State           : Backup
Causation       : -
System ID       : 0025-9e95-7c11
SysName         : SwitchB
Version         : V100R006C00
Device Type     : CE6850EI
    
```

Check M-LAG information on SwitchA.

```

[~SwitchA] display dfs-group 1 node 1 m-lag brief
* - Local node

M-Lag ID      Interface      Port State      Status
-----
1             Eth-Trunk 1      Up             active(*)-active
    
```

Check M-LAG information on SwitchB.

```

[~SwitchA] display dfs-group 1 node 2 m-lag brief
* - Local node

M-Lag ID      Interface      Port State      Status
-----
1             Eth-Trunk 1      Up             active-active(*)
    
```

In the preceding information, the value of **Heart beat state** is **OK**, indicating that the heartbeat is normal. SwitchA is used as Node 1, its priority is 150, and its status is **Master**. SwitchB is used as Node 2, its priority is 120, and its status is **Backup**. The value of **Causation** is -, and the values of **Port State** of Node 1 and Node 2 are both **Up**, and the M-LAG status of Node 1 and Node 2 is both **active**, indicating that the M-LAG configuration is correct.

- Run the **display vrrp** command on SwitchC and SwitchD. You can see that SwitchC is in Master state and SwitchD is in Backup state.

```

[~SwitchC] display vrrp verbose
Vlanif11 | Virtual Router 1
State      : Master
Virtual IP : 10.2.1.111
Master IP  : 10.2.1.1
PriorityRun : 120
PriorityConfig : 120
MasterPriority : 120
Preempt    : YES   Delay Time : 0s   Remain : --
TimerRun   :
1s
TimerConfig : 1s
Auth Type  :
NONE
Virtual MAC :
0000-5e00-0101
Check TTL  :
YES
Config Type : Normal
Create Time : 2015-01-30
11:39:18
Last Change Time : 2015-02-04 11:38:58
[~SwitchD] display vrrp verbose
Vlanif11 | Virtual Router 1
State      : Backup
Virtual IP : 10.2.1.111
Master IP  : 10.2.1.1
PriorityRun : 100
PriorityConfig : 100
MasterPriority : 120
Preempt    : YES   Delay Time : 0s   Remain : --
TimerRun   : 1s
TimerConfig : 1s
    
```

```
Auth Type      : NONE
Virtual MAC    : 0000-5e00-0101
Check TTL      : YES
Config Type    : Normal
Create Time    : 2015-01-30 11:39:18
Last Change Time : 2015-02-04 11:38:58
```

----End

Configuration Files

- SwitchA configuration file

```
#
sysname SwitchA
#
dfs-group 1
  priority 150
  source ip 10.1.1.1
#
vlan batch 11
#
stp bridge-address 0039-0039-0039
stp instance 0 root primary
#
lacp m-lag system-id 00e0-fc00-0000
lacp m-lag priority 10
#
interface Eth-Trunk0
  stp disable
  mode lacp-static
  peer-link 1
#
interface Eth-Trunk1
  port default vlan 11
  stp edged-port enable
  mode lacp-dynamic
  dfs-group 1 m-lag 1
#
interface Eth-Trunk2
  port link-type trunk
  port trunk allow-pass vlan 11
  mode lacp-static
#
interface 10GE1/0/1
  eth-trunk 2
#
interface 10GE1/0/2
  eth-trunk 2
#
interface 10GE1/0/3
  undo portswitch
  ip address 10.1.1.1 255.255.255.0
#
interface 10GE1/0/4
  eth-trunk 0
#
interface 10GE1/0/5
  eth-trunk 0
#
interface 10GE1/0/6
  eth-trunk 1
#
interface 10GE1/0/7
  eth-trunk 1
#
return
```

- SwitchB configuration file

```
#
sysname SwitchB
#
dfs-group 1
  priority 120
  source ip 10.1.1.2
#
vlan batch 11
#
stp bridge-address 0039-0039-0039
stp instance 0 root primary
#
lacp m-lag system-id 00e0-fc00-0000
lacp m-lag priority 10
#
interface Eth-Trunk0
  stp disable
  mode lacp-static
  peer-link 1
#
interface Eth-Trunk1
  port default vlan 11
  stp edged-port enable
  mode lacp-dynamic
  dfs-group 1 m-lag 1
#
interface Eth-Trunk2
  port link-type trunk
  port trunk allow-pass vlan 11
  mode lacp-static
#
interface 10GE1/0/1
  eth-trunk 2
#
interface 10GE1/0/2
  eth-trunk 2
#
interface 10GE1/0/3
  undo portswitch
  ip address 10.1.1.2 255.255.255.0
#
interface 10GE1/0/4
  eth-trunk 0
#
interface 10GE1/0/5
  eth-trunk 0
#
interface 10GE1/0/6
  eth-trunk 1
#
interface 10GE1/0/7
  eth-trunk 1
#
return
```

● SwitchC configuration file

```
#
sysname SwitchC
#
vlan batch 11
#
interface Vlanif11
  ip address 10.2.1.1 255.255.255.0
  vrrp vrid 1 virtual-ip 10.2.1.111
  vrrp vrid 1 priority 120
#
interface Eth-Trunk2
  port link-type trunk
  port trunk allow-pass vlan 11
  mode lacp-static
```

```
#
interface 10GE1/0/1
 eth-trunk 2
#
interface 10GE1/0/2
 eth-trunk 2
#
return
```

- SwitchD configuration file

```
#
sysname SwitchD
#
vlan batch 11
#
interface Vlanif11
 ip address 10.2.1.2 255.255.255.0
 vrrp vrid 1 virtual-ip 10.2.1.111
#
interface Eth-Trunk2
 port link-type trunk
 port trunk allow-pass vlan 11
 mode lacp-static
#
interface 10GE1/0/1
 eth-trunk 2
#
interface 10GE1/0/2
 eth-trunk 2
#
return
```

1.7.3 Example for Deploying M-LAG on a Dual-Homing TRILL Network Through V-STP

Networking Requirements

As shown in [Figure 1-31](#), the switch connects to a TRILL network. The requirements are as follows:

- When one access link fails, traffic can be fast switched to the other link to ensure reliability.
- The load balancing mode can be used to forward traffic to make full use of bandwidth and ensure that two links are in active state.

Figure 1-31 Dual homing to a TRILL network through M-LAG

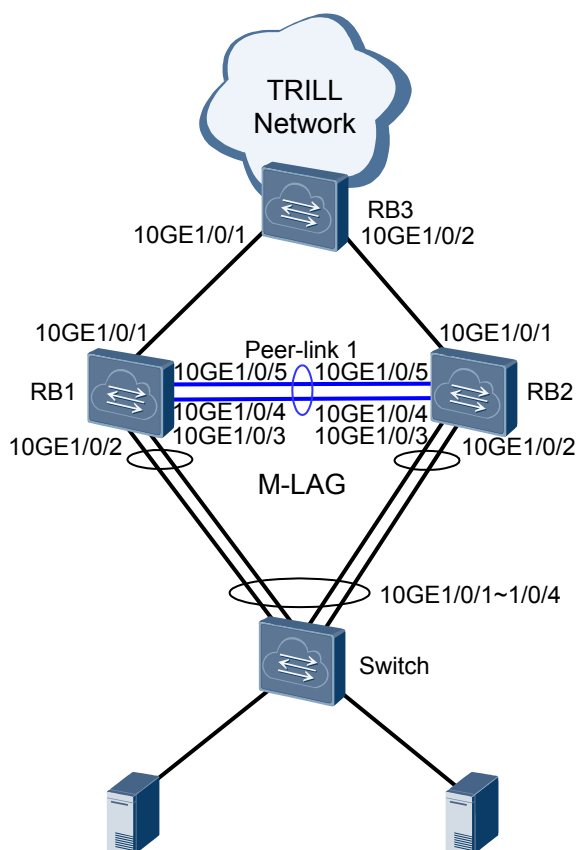

You can configure M-LAG and connect the device to the TRILL network through two RBs. M-LAG is configured between the device and RBs to enhance device-level and link-level reliability. RB1 and RB2 use the same pseudo nickname to form a logical device. On RBs, the DFS group is associated with M-LAG and TRILL. M-LAG and TRILL ensure that service packets are correctly forwarded.

Configuration Roadmap

The configuration roadmap is as follows:

1. Configure basic TRILL functions on RBs to implement interworking of the TRILL network.
2. Configure M-LAG on RB1 and RB2 so that the device is dual-homed to RB1 and RB2.
3. On RB1 and RB2, associate uplink and downlink interfaces with the Monitor Link group to prevent a user-side traffic forwarding failure and traffic loss due to the uplink fault.

Procedure

Step 1 Configure basic TRILL functions on RBs.

Configure RB1.

```
<HUAWAI> system-view
[~HUAWAI] sysname RB1
[*HUAWAI] commit
[~RB1] vlan batch 100
```

```
[*RB1] trill
[*RB1-trill] network-entity 00.0000.0000.1111.00
[*RB1-trill] nickname 100
[*RB1-trill] carrier-vlan 2
[*RB1-trill] ce-vlan 100
[*RB1-trill] quit
[*RB1] interface 10ge 1/0/1
[*RB1-10GE1/0/1] port link-type trunk
[*RB1-10GE1/0/1] trill enable
[*RB1-10GE1/0/1] quit
[*RB1] commit
```

Configure RB2.

```
<HUAWEI> system-view
[~HUAWEI] sysname RB2
[*HUAWEI] commit
[~RB2] vlan batch 100
[*RB2] trill
[*RB2-trill] network-entity 00.0000.0000.2222.00
[*RB2-trill] nickname 200
[*RB2-trill] carrier-vlan 2
[*RB2-trill] ce-vlan 100
[*RB2-trill] quit
[*RB2] interface 10ge 1/0/1
[*RB2-10GE1/0/1] port link-type trunk
[*RB2-10GE1/0/1] trill enable
[*RB2-10GE1/0/1] quit
[*RB2] commit
```

Configure RB3.

```
<HUAWEI> system-view
[~HUAWEI] sysname RB3
[*HUAWEI] commit
[~RB3] trill
[*RB3-trill] network-entity 00.0000.0000.3333.00
[*RB3-trill] nickname 400
[*RB3-trill] carrier-vlan 2
[*RB3-trill] quit
[*RB3] interface 10ge 1/0/1
[*RB3-10GE1/0/1] port link-type trunk
[*RB3-10GE1/0/1] trill enable
[*RB3-10GE1/0/1] quit
[*RB3] interface 10ge 1/0/2
[*RB3-10GE1/0/2] port link-type trunk
[*RB3-10GE1/0/2] trill enable
[*RB3-10GE1/0/2] quit
[*RB3] commit
```

After the configuration is complete, run the **display trill peer** command to check TRILL peer information.

```
[~RB1] display trill peer

Peer information for TRILL
-----
Total Peer(s): 1

System ID/Trill Name  Interface      Circuit ID      State  HoldTime Type  PRI
-----
0000.0000.3333       10GE1/0/1     0000.0000.3333.02 Report      7s L1    64
```

Step 2 On the switch, bind the uplink interface to an Eth-Trunk.

Configure the switch.

```
<HUAWEI> system-view
[~HUAWEI] sysname Switch
```

```
[*HUAWEI] commit
[~Switch] vlan batch 100
[*Switch] interface eth-trunk 20
[*Switch-Eth-Trunk20] mode lacp-static
[*Switch-Eth-Trunk20] port link-type trunk
[*Switch-Eth-Trunk20] port trunk allow-pass vlan 100
[*Switch-Eth-Trunk20] trunkport 10ge 1/0/1 to 1/0/4
[*Switch-Eth-Trunk20] quit
[*Switch] commit
```

Step 3 Configure the V-STP, DFS group, peer-link, and M-LAG interface on RB1 and RB2.

Configure RB1.

```
[~RB1] stp mode rstp
[*RB1] stp v-stp enable
[*RB1] dfs-group 1
[*RB1-dfs-group-1] source nickname 100
[*RB1-dfs-group-1] pseudo-nickname 500
[*RB1-dfs-group-1] priority 150
[*RB1-dfs-group-1] quit
[*RB1] interface eth-trunk 1
[*RB1-Eth-Trunk1] trunkport 10ge 1/0/4
[*RB1-Eth-Trunk1] trunkport 10ge 1/0/5
[*RB1-Eth-Trunk1] mode lacp-static
[*RB1-Eth-Trunk1] peer-link 1
[*RB1-Eth-Trunk1] port vlan exclude 2
[*RB1-Eth-Trunk1] quit
[*RB1] interface eth-trunk 10
[*RB1-Eth-Trunk10] mode lacp-static
[*RB1-Eth-Trunk10] port link-type trunk
[*RB1-Eth-Trunk10] port trunk allow-pass vlan 100
[*RB1-Eth-Trunk10] trunkport 10ge 1/0/2
[*RB1-Eth-Trunk10] trunkport 10ge 1/0/3
[*RB1-Eth-Trunk10] dfs-group 1 m-lag 1
[*RB1-Eth-Trunk10] quit
[*RB1] commit
```

Configure RB2.

```
[~RB2] stp mode rstp
[*RB2] stp v-stp enable
[*RB2] dfs-group 1
[*RB2-dfs-group-1] source nickname 200
[*RB2-dfs-group-1] pseudo-nickname 500
[*RB2-dfs-group-1] priority 120
[*RB2-dfs-group-1] quit
[*RB2] interface eth-trunk 1
[*RB2-Eth-Trunk1] trunkport 10ge 1/0/4
[*RB2-Eth-Trunk1] trunkport 10ge 1/0/5
[*RB2-Eth-Trunk1] mode lacp-static
[*RB2-Eth-Trunk1] peer-link 1
[*RB2-Eth-Trunk1] port vlan exclude 2
[*RB2-Eth-Trunk1] quit
[*RB2] interface eth-trunk 10
[*RB2-Eth-Trunk10] mode lacp-static
[*RB2-Eth-Trunk10] port link-type trunk
[*RB2-Eth-Trunk10] port trunk allow-pass vlan 100
[*RB2-Eth-Trunk10] trunkport 10ge 1/0/2
[*RB2-Eth-Trunk10] trunkport 10ge 1/0/3
[*RB2-Eth-Trunk10] dfs-group 1 m-lag 1
[*RB2-Eth-Trunk10] quit
[*RB2] commit
```

Step 4 Configure the LACP M-LAG system priority and system ID on RB1 and RB2.

Configure RB1.

```
[~RB1] lacp m-lag priority 10
[*RB1] lacp m-lag system-id 00e0-fc00-0000
[*RB1] commit
```

```
# Configure RB2.
[~RB2] lacp m-lag priority 10
[*RB2] lacp m-lag system-id 00e0-fc00-0000
[*RB2] commit
```

Step 5 On RB1 and RB2, associate uplink and downlink interfaces with the Monitor Link group.

```
# Configure RB1.
[~RB1] monitor-link group 1
[*RB1-mtlk-group1] port 10ge 1/0/1 uplink
[*RB1-mtlk-group1] port eth-trunk 10 downlink 1
[*RB1-mtlk-group1] quit
[*RB1] commit
```

```
# Configure RB2.
[~RB2] monitor-link group 1
[*RB2-mtlk-group1] port 10ge 1/0/1 uplink
[*RB2-mtlk-group1] port eth-trunk 10 downlink 1
[*RB2-mtlk-group1] quit
[*RB2] commit
```

Step 6 Verify the configuration.

Run the **display dfs-group** command to check M-LAG information.

Check information about the M-LAG with DFS group 1.

```
[~RB1] display dfs-group 1 m-lag
*
: Local node
Heart beat state : OK
Node 1 *
  Dfs-Group ID   : 1
  Priority       : 150
  Address        : nickname 100
  State         : Master
  Causation      : -
  System ID     : 0025-9e95-7c31
  SysName       : RB1
  Version       : V100R006C00
  Device Type   : CE6850EI
Node 2
  Dfs-Group ID   : 1
  Priority       : 120
  Address        : nickname 200
  State         : Backup
  Causation      : -
  System ID     : 0025-9e95-7c11
  SysName       : RB2
  Version       : V100R006C00
  Device Type   : CE6850EI
```

Check M-LAG information on RB1.

```
[~RB1] display dfs-group 1 node 1 m-lag brief
* - Local node

M-Lag ID      Interface      Port State      Status
-----
1             Eth-Trunk 10   Up              active(*)-active
```

Check M-LAG information on RB2.

```
[~RB1] display dfs-group 1 node 2 m-lag brief
* - Local node

M-Lag ID      Interface      Port State      Status
-----
1             Eth-Trunk 10   Up              active-active(*)
```

In the preceding information, the value of **Heart beat state** is **OK**, indicating that the heartbeat is normal. RB1 is used as Node 1, its priority is 150, and its status is **Master**. RB2 is

used as Node 2, its priority is 120, and its status is **Backup**. The value of **Causation** is -, the values of **Port State** of Node 1 and Node 2 are both **Up**, and the M-LAG status of both Node 1 and Node 2 is **active**, indicating that the M-LAG configuration is correct.

----End

Configuration Files

- RB1 configuration file

```
#
sysname RB1
#
dfs-group 1
  priority 150
  source nickname 100
  pseudo-nickname 500
#
vlan batch 100
#
stp mode rstp
stp v-stp enable
#
lACP m-lag system-id 00e0-fc00-0000
lACP m-lag priority 10
#
trill
  network-entity 00.0000.0000.1111.00
  nickname 100
  carrier-vlan 2
  ce-vlan 100
#
interface Eth-Trunk1
  mode lACP-static
  peer-link 1
  port vlan exclude 2
#
interface Eth-Trunk10
  port link-type trunk
  port trunk allow-pass vlan 100
  mode lACP-static
  dfs-group 1 m-lag 1
#
interface 10GE1/0/1
  port link-type trunk
  undo port trunk allow-pass vlan 1
  trill enable
#
interface 10GE1/0/2
  eth-trunk 10
#
interface 10GE1/0/3
  eth-trunk 10
#
interface 10GE1/0/4
  eth-trunk 1
#
interface 10GE1/0/5
  eth-trunk 1
#
monitor-link group 1
  port 10GE1/0/1 uplink
  port Eth-Trunk10 downlink 1
#
return
```

- RB2 configuration file

```
#
sysname RB2
```

```
#
dfs-group 1
  priority 120
  source nickname 200
  pseudo-nickname 500
#
vlan batch 100
#
stp mode rstp
stp v-stp enable
#
lACP m-lag system-id 00e0-fc00-0000
lACP m-lag priority 10
#
trill
  network-entity 00.0000.0000.2222.00
  nickname 200
  carrier-vlan 2
  ce-vlan 100
#
interface Eth-Trunk1
  mode lacp-static
  peer-link 1
  port vlan exclude 2
#
interface Eth-Trunk10
  port link-type trunk
  port trunk allow-pass vlan 100
  mode lacp-static
  dfs-group 1 m-lag 1
#
interface 10GE1/0/1
  port link-type trunk
  undo port trunk allow-pass vlan 1
  trill enable
#
interface 10GE1/0/2
  eth-trunk 10
#
interface 10GE1/0/3
  eth-trunk 10
#
interface 10GE1/0/4
  eth-trunk 1
#
interface 10GE1/0/5
  eth-trunk 1
#
monitor-link group 1
  port 10GE1/0/1 uplink
  port Eth-Trunk10 downlink 1
#
return
```

- RB3 configuration file

```
#
sysname RB3
#
trill
  network-entity 00.0000.0000.3333.00
  nickname 400
  carrier-vlan 2
#
interface 10GE1/0/1
  port link-type trunk
  undo port trunk allow-pass vlan 1
  trill enable
#
interface 10GE1/0/2
  port link-type trunk
```

```
undo port trunk allow-pass vlan 1
trill enable
#
return
```

- Switch configuration file

```
#
sysname Switch
#
vlan batch 100
#
interface Eth-Trunk20
port link-type trunk
port trunk allow-pass vlan 100
mode lacp-static
#
interface 10GE1/0/1
eth-trunk 20
#
interface 10GE1/0/2
eth-trunk 20
#
interface 10GE1/0/3
eth-trunk 20
#
interface 10GE1/0/4
eth-trunk 20
#
return
```

1.7.4 Example for Dual-Homing a Switch to an IP Network Through V-STP

Networking Requirements

As shown in [Figure 1-32](#), the switch is dual-homed to the IP network through M-LAG. The requirements are as follows:

- When one access link fails, traffic can be fast switched to the other link to ensure reliability.
- The load balancing mode can be used to forward traffic to make full use of bandwidth and ensure that two links are in active state.

Figure 1-32 Dual homing to an IP network through M-LAG

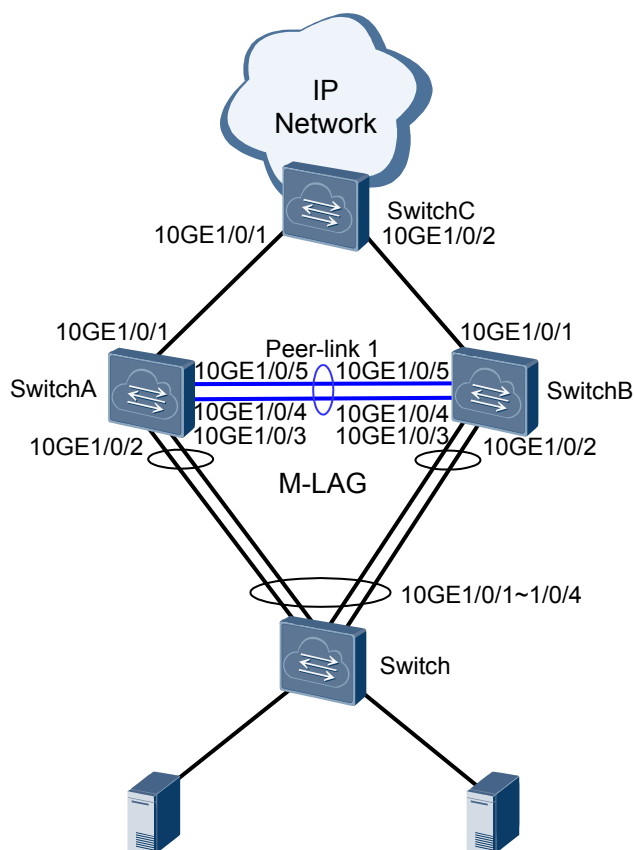

Configuration Roadmap

The configuration roadmap is as follows:

1. On the switch, bind the uplink interface to an Eth-Trunk.
2. Configure the V-STP, DFS group, peer-link, and M-LAG interface on SwitchA and SwitchB.
3. Configure the LACP M-LAG system priority and system ID on SwitchA and SwitchB.
4. On SwitchA and SwitchB, configure an IP address and a MAC address for a VLANIF interface to implement dual-active gateway of access devices.
5. Configure OSPF on SwitchA, SwitchB, and SwitchC to ensure Layer 3 connectivity.

NOTE

In a V-STP scenario, to prevent a port from being blocked due to the spanning tree calculation result, configure the main interface to implement Layer 3 connectivity or disable the spanning tree protocol on the IP network.

6. On SwitchA and SwitchB, associate uplink and downlink interfaces with the Monitor Link group to prevent a user-side traffic forwarding failure and traffic loss due to the uplink fault.

Procedure

Step 1 On the switch, bind the uplink interface to an Eth-Trunk.

Configure the switch.

```
<HUAWEI> system-view
[~HUAWEI] sysname Switch
[*HUAWEI] commit
[~Switch] vlan batch 11
[*Switch] interface eth-trunk 20
[*Switch-Eth-Trunk20] mode lacp-static
[*Switch-Eth-Trunk20] port link-type trunk
[*Switch-Eth-Trunk20] port trunk allow-pass vlan 11
[*Switch-Eth-Trunk20] trunkport 10ge 1/0/1 to 1/0/4
[*Switch-Eth-Trunk20] quit
[*Switch] commit
```

Step 2 Configure the V-STP, DFS group, peer-link, and M-LAG interface on SwitchA and SwitchB.

Configure SwitchA.

```
<HUAWEI> system-view
[~HUAWEI] sysname SwitchA
[*HUAWEI] commit
[~SwitchA] stp mode rstp
[*SwitchA] stp v-stp enable
[*SwitchA] interface loopback 0
[*SwitchA-LoopBack0] ip address 10.1.1.1 32
[*SwitchA-LoopBack0] quit
[*SwitchA] dfs-group 1
[*SwitchA-dfs-group-1] source ip 10.1.1.1
[*SwitchA-dfs-group-1] priority 150
[*SwitchA-dfs-group-1] quit
[*SwitchA] interface eth-trunk 1
[*SwitchA-Eth-Trunk1] trunkport 10ge 1/0/4
[*SwitchA-Eth-Trunk1] trunkport 10ge 1/0/5
[*SwitchA-Eth-Trunk1] mode lacp-static
[*SwitchA-Eth-Trunk1] peer-link 1
[*SwitchA-Eth-Trunk1] quit
[*SwitchA] vlan batch 11
[*SwitchA] interface eth-trunk 10
[*SwitchA-Eth-Trunk10] mode lacp-static
[*SwitchA-Eth-Trunk10] port link-type trunk
[*SwitchA-Eth-Trunk10] port trunk allow-pass vlan 11
[*SwitchA-Eth-Trunk10] trunkport 10ge 1/0/2
[*SwitchA-Eth-Trunk10] trunkport 10ge 1/0/3
[*SwitchA-Eth-Trunk10] dfs-group 1 m-lag 1
[*SwitchA-Eth-Trunk10] quit
[*SwitchA] commit
```

Configure SwitchB.

```
<HUAWEI> system-view
[~HUAWEI] sysname SwitchB
[*HUAWEI] commit
[~SwitchB] stp mode rstp
[*SwitchB] stp v-stp enable
[*SwitchB] interface loopback 0
[*SwitchB-LoopBack0] ip address 10.1.1.2 32
[*SwitchB-LoopBack0] quit
[*SwitchB] dfs-group 1
[*SwitchB-dfs-group-1] source ip 10.1.1.2
[*SwitchB-dfs-group-1] priority 120
[*SwitchB-dfs-group-1] quit
[*SwitchB] interface eth-trunk 1
[*SwitchB-Eth-Trunk1] trunkport 10ge 1/0/4
[*SwitchB-Eth-Trunk1] trunkport 10ge 1/0/5
[*SwitchB-Eth-Trunk1] mode lacp-static
[*SwitchB-Eth-Trunk1] peer-link 1
[*SwitchB-Eth-Trunk1] quit
[*SwitchB] vlan batch 11
[*SwitchB] interface eth-trunk 10
[*SwitchB-Eth-Trunk10] mode lacp-static
[*SwitchB-Eth-Trunk10] port link-type trunk
[*SwitchB-Eth-Trunk10] port trunk allow-pass vlan 11
```

```
[*SwitchB-Eth-Trunk10] trunkport 10ge 1/0/2
[*SwitchB-Eth-Trunk10] trunkport 10ge 1/0/3
[*SwitchB-Eth-Trunk10] dfs-group 1 m-lag 1
[*SwitchB-Eth-Trunk10] quit
[*SwitchB] commit
```

Step 3 Configure the LACP M-LAG system priority and system ID on SwitchA and SwitchB.

Configure SwitchA.

```
[~SwitchA] lacp m-lag priority 10
[*SwitchA] lacp m-lag system-id 00e0-fc00-0000
[*SwitchA] commit
```

Configure SwitchB.

```
[~SwitchB] lacp m-lag priority 10
[*SwitchB] lacp m-lag system-id 00e0-fc00-0000
[*SwitchB] commit
```

Step 4 On SwitchA and SwitchB, configure an IP address and a MAC address for a VLANIF interface to implement dual-active gateway of access devices.

VLANIF interfaces corresponding to M-LAG member interfaces of M-LAG master and backup devices must be configured with the same IP address and MAC address so that M-LAG devices use the same virtual IP address and virtual MAC address.

Configure SwitchA.

```
[~SwitchA] interface vlanif 11
[*SwitchA-Vlanif11] ip address 10.2.1.1 24
[*SwitchA-Vlanif11] mac-address 0000-5e00-0101
[*SwitchA-Vlanif11] quit
[*SwitchA] commit
```

Configure SwitchB.

```
[~SwitchB] interface vlanif 11
[*SwitchB-Vlanif11] ip address 10.2.1.1 24
[*SwitchB-Vlanif11] mac-address 0000-5e00-0101
[*SwitchB-Vlanif11] quit
[*SwitchB] commit
```

Step 5 Configure OSPF on SwitchA, SwitchB, and SwitchC to ensure Layer 3 connectivity.

Configure SwitchA.

```
[~SwitchA] interface 10ge 1/0/1
[~SwitchA-10GE1/0/1] undo portswitch
[*SwitchA-10GE1/0/1] ip address 10.3.1.1 24
[*SwitchA-10GE1/0/1] quit
[*SwitchA] ospf 1
[*SwitchA-ospf-1] area 0
[*SwitchA-ospf-1-area-0.0.0.0] network 10.1.1.1 0.0.0.0
[*SwitchA-ospf-1-area-0.0.0.0] network 10.2.1.0 0.0.0.255
[*SwitchA-ospf-1-area-0.0.0.0] network 10.3.1.0 0.0.0.255
[*SwitchA-ospf-1-area-0.0.0.0] quit
[*SwitchA-ospf-1] quit
[*SwitchA] commit
```

Configure SwitchB.

```
[~SwitchB] interface 10ge 1/0/1
[~SwitchB-10GE1/0/1] undo portswitch
[*SwitchB-10GE1/0/1] ip address 10.4.1.1 24
[*SwitchB-10GE1/0/1] quit
[*SwitchB] ospf 1
[*SwitchB-ospf-1] area 0
[*SwitchB-ospf-1-area-0.0.0.0] network 10.1.1.2 0.0.0.0
[*SwitchB-ospf-1-area-0.0.0.0] network 10.2.1.0 0.0.0.255
[*SwitchB-ospf-1-area-0.0.0.0] network 10.4.1.0 0.0.0.255
[*SwitchB-ospf-1-area-0.0.0.0] quit
[*SwitchB-ospf-1] quit
[*SwitchB] commit
```

Configure SwitchC.

```
<HUAWEI> system-view
[~HUAWEI] sysname SwitchC
[*HUAWEI] commit
[~SwitchC] interface 10ge 1/0/1
[~SwitchC-10GE1/0/1] undo portswitch
[*SwitchC-10GE1/0/1] ip address 10.3.1.2 24
[*SwitchC-10GE1/0/1] quit
[*SwitchC] interface 10ge 1/0/2
[*SwitchC-10GE1/0/2] undo portswitch
[*SwitchC-10GE1/0/2] ip address 10.4.1.2 24
[*SwitchC-10GE1/0/2] quit
[*SwitchC] ospf 1
[*SwitchC-ospf-1] area 0
[*SwitchC-ospf-1-area-0.0.0.0] network 10.3.1.0 0.0.0.255
[*SwitchC-ospf-1-area-0.0.0.0] network 10.4.1.0 0.0.0.255
[*SwitchC-ospf-1-area-0.0.0.0] quit
[*SwitchC-ospf-1] quit
```

Step 6 On SwitchA and SwitchB, associate uplink and downlink interfaces with the Monitor Link group.

Configure SwitchA.

```
[~SwitchA] monitor-link group 1
[*SwitchA-mtlk-group1] port 10ge 1/0/1 uplink
[*SwitchA-mtlk-group1] port eth-trunk 10 downlink 1
[*SwitchA-mtlk-group1] quit
[*SwitchA] commit
```

Configure SwitchB.

```
[~SwitchB] monitor-link group 1
[*SwitchB-mtlk-group1] port 10ge 1/0/1 uplink
[*SwitchB-mtlk-group1] port eth-trunk 10 downlink 1
[*SwitchB-mtlk-group1] quit
[*SwitchB] commit
```

Step 7 Verify the configuration.

Run the **display dfs-group** command to check M-LAG information.

Check information about the M-LAG with DFS group 1.

```
[~SwitchA] display dfs-group 1 m-lag
*           : Local node
Heart beat state : OK
Node 1 *
  Dfs-Group ID   : 1
  Priority        : 150
  Address         : ip address 10.1.1.1
  State          : Master
  Causation      : -
  System ID      : 0025-9e95-7c31
  SysName        : SwitchA
  Version        : V100R006C00
  Device Type    : CE6850EI
Node 2
  Dfs-Group ID   : 1
  Priority        : 120
  Address         : ip address 10.1.1.2
  State          : Backup
  Causation      : -
  System ID      : 0025-9e95-7c11
  SysName        : SwitchB
  Version        : V100R006C00
  Device Type    : CE6850EI
```

Check M-LAG information on SwitchA.

```
[~SwitchA] display dfs-group 1 node 1 m-lag brief
* - Local node

M-Lag ID      Interface      Port State      Status
   1          Eth-Trunk 10    Up              active(*)-active
```

Check M-LAG information on SwitchB.

```
[~SwitchA] display dfs-group 1 node 2 m-lag brief
* - Local node

M-Lag ID      Interface      Port State      Status
   1          Eth-Trunk 10    Up              active-active(*)
```

In the preceding information, the value of **Heart beat state** is **OK**, indicating that the heartbeat is normal. SwitchA is used as Node 1, its priority is 150, and its status is **Master**. SwitchB is used as Node 2, its priority is 120, and its status is **Backup**. The value of **Causation** is -, the values of **Port State** of Node 1 and Node 2 are both **Up**, and the M-LAG status of both Node 1 and Node 2 is **active**, indicating that the M-LAG configuration is correct.

----End

Configuration Files

- SwitchA configuration file

```
#
sysname SwitchA
#
dfs-group 1
  priority 150
  source ip 10.1.1.1
#
vlan batch 11
#
stp mode rstp
stp v-stp enable
#
lacp m-lag system-id 00e0-fc00-0000
lacp m-lag priority 10
#
interface Vlanif11
  ip address 10.2.1.1
  255.255.255.0

  mac-address 0000-5e00-0101
#
interface Eth-Trunk1
  mode lacp-static
  peer-link 1
#
interface Eth-Trunk10
  port link-type trunk
  port trunk allow-pass vlan 11
  mode lacp-static
  dfs-group 1 m-lag 1
#
interface 10GE1/0/1
  undo portswitch
  ip address 10.3.1.1 255.255.255.0
#
interface 10GE1/0/2
  eth-trunk 10
#
interface 10GE1/0/3
  eth-trunk 10
#
```



```
interface 10GE1/0/4
 eth-trunk 1
#
interface 10GE1/0/5
 eth-trunk 1
#
interface LoopBack0
 ip address 10.1.1.1 255.255.255.255
#
monitor-link group 1
 port 10GE1/0/1 uplink
 port Eth-Trunk10 downlink 1
#
ospf 1
 area 0.0.0.0
  network 10.1.1.1 0.0.0.0
  network 10.2.1.0 0.0.0.255
  network 10.3.1.0 0.0.0.255
#
return
```

● SwitchB configuration file

```
#
sysname SwitchB
#
dfs-group 1
 priority 120
 source ip 10.1.1.2
#
vlan batch 11
#
stp mode rstp
stp v-stp enable
#
lACP m-lag system-id 00e0-fc00-0000
lACP m-lag priority 10
#
interface Vlanif11
 ip address 10.2.1.1
 255.255.255.0
#
 mac-address 0000-5e00-0101
#
interface Eth-Trunk1
 mode lACP-static
 peer-link 1
#
interface Eth-Trunk10
 port link-type trunk
 port trunk allow-pass vlan 11
 mode lACP-static
 dfs-group 1 m-lag 1
#
interface 10GE1/0/1
 undo portswitch
 ip address 10.4.1.1 255.255.255.0
#
interface 10GE1/0/2
 eth-trunk 10
#
interface 10GE1/0/3
 eth-trunk 10
#
interface 10GE1/0/4
 eth-trunk 1
#
interface 10GE1/0/5
 eth-trunk 1
#
interface LoopBack0
```

```

ip address 10.1.1.2 255.255.255.255
#
monitor-link group 1
port 10GE1/0/1 uplink
port Eth-Trunk10 downlink 1
#
ospf 1
area 0.0.0.0
network 10.1.1.2 0.0.0.0
network 10.2.1.0 0.0.0.255
network 10.4.1.0 0.0.0.255
#
return

```

- SwitchC configuration file

```

#
sysname SwitchC
#
interface 10GE1/0/1
undo portswitch
ip address 10.3.1.2 255.255.255.0
#
interface 10GE1/0/2
undo portswitch
ip address 10.4.1.2 255.255.255.0
#
ospf 1
area 0.0.0.0
network 10.3.1.0 0.0.0.255
network 10.4.1.0 0.0.0.255
#
return

```

- Switch configuration file

```

#
sysname Switch
#
vlan batch 11
#
interface Eth-Trunk20
port link-type trunk
port trunk allow-pass vlan 11
mode lacp-static
#
interface 10GE1/0/1
eth-trunk 20
#
interface 10GE1/0/2
eth-trunk 20
#
interface 10GE1/0/3
eth-trunk 20
#
interface 10GE1/0/4
eth-trunk 20
#
return

```

1.7.5 Example for Configuring VXLAN All-Active Access (In Single-Node Mode)

Networking Requirements

The network shown in [Figure 1-33](#) has the following requirements when servers access the VXLAN network:

- To ensure high reliability, the server is dual-homed to two leaf devices. When one access link fails, traffic can be rapidly switched to the other link.
- To improve bandwidth utilization, two links are in active state simultaneously to load balance traffic.

Figure 1-33 VXLAN dual-active access networking

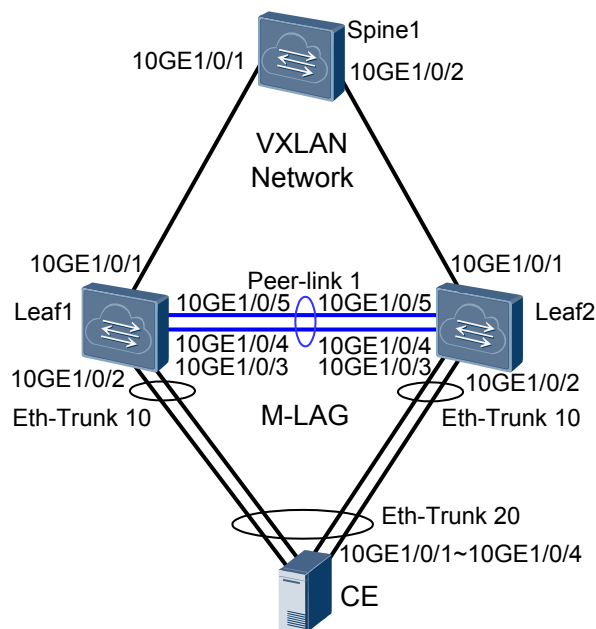

Configuration Roadmap

The configuration roadmap is as follows:

1. Configure a routing protocol on Leaf1, Leaf2, and Spine1 to ensure Layer 3 network connectivity.
2. Configure basic VXLAN functions on Leaf1, Leaf2, and Spine1 to ensure VXLAN network connectivity.
3. Create Eth-Trunks.
4. Configure Leaf1 and Leaf2 as root bridges and configure the same bridge ID for them.
5. Configure M-LAG.
 - Associate a DFS group with VXLAN on Leaf1 and Leaf2.
 - Configure a link between Leaf1 and Leaf2 as the peer link.
 - Bind the user-side Eth-Trunk to the DFS group on Leaf1 and Leaf2.

NOTE

If the link through which Leaf1 is uplink connected to the VXLAN network fails, Leaf1 discards all received user traffic because no uplink outbound interface is available. You can configure a monitor-link to associate the uplink and downlink interfaces of Leaf1. When the uplink outbound interface of Leaf1 becomes Down, the downlink interface also becomes Down. Then user traffic will not be forwarded or discarded by Leaf1. For details about the monitor-link configuration, see *Configuring the Uplink and Downlink Interfaces in a Monitor Link Group*.

Data Plan

To complete the configuration, you need the following data:

- Interface IP addresses for device interconnection
- Routing protocol: OSPF
- VLAN ID to which VMs belong: VLAN 10
- BD ID: BD 10
- VNI ID: VNI 5010

Procedure

Step 1 Configure a routing protocol.

Configure Leaf1. The configurations on Spine1 and Leaf2 are similar to that on Leaf1, and are not mentioned here. When OSPF is used, the devices advertise the 32-bit loopback IP addresses.

```
<HUAWEI> system-view
[~HUAWEI] sysname Leaf1
[*HUAWEI] commit
[~Leaf1] interface loopback 1
[*Leaf1-LoopBack1] ip address 10.2.2.2 32
[*Leaf1-LoopBack1] quit
[*Leaf1] interface loopback 2
[*Leaf1-LoopBack2] ip address 10.3.3.3 32
[*Leaf1-LoopBack2] quit
[*Leaf1] interface 10ge 1/0/1
[*Leaf1-10GE1/0/1] undo portswitch
[*Leaf1-10GE1/0/1] ip address 192.168.1.1 24
[*Leaf1-10GE1/0/1] quit
[*Leaf1] ospf
[*Leaf1-ospf-1] area 0
[*Leaf1-ospf-1-area-0.0.0.0] network 10.2.2.2 0.0.0.0
[*Leaf1-ospf-1-area-0.0.0.0] network 10.3.3.3 0.0.0.0
[*Leaf1-ospf-1-area-0.0.0.0] network 192.168.1.0 0.0.0.255
[*Leaf1-ospf-1-area-0.0.0.0] quit
[*Leaf1-ospf-1] quit
[*Leaf1] commit
```

After OSPF is configured, the devices can learn the loopback IP address of each other and successfully ping each other. The following shows the ping result from Leaf1 to Spine1.

```
[~Leaf1] ping 10.1.1.1
PING 10.1.1.1: 56 data bytes, press CTRL_C to break
Reply from 10.1.1.1: bytes=56 Sequence=1 ttl=254 time=5 ms
Reply from 10.1.1.1: bytes=56 Sequence=2 ttl=254 time=2 ms
Reply from 10.1.1.1: bytes=56 Sequence=3 ttl=254 time=2 ms
Reply from 10.1.1.1: bytes=56 Sequence=4 ttl=254 time=3 ms
Reply from 10.1.1.1: bytes=56 Sequence=5 ttl=254 time=3 ms

--- 10.1.1.1 ping statistics ---
 5 packet(s) transmitted
 5 packet(s) received
 0.00% packet loss
 round-trip min/avg/max = 2/3/5 ms
```

Step 2 Configure VXLAN tunnels between Leaf1, Leaf2, and Spine1.

Configure Leaf1. The configuration on Leaf2 is similar to that on Leaf1, and is not mentioned here.

```
[~Leaf1] bridge-domain 10
[*Leaf1-bd10] vxlan vni 5010
[*Leaf1-bd10] quit
[*Leaf1] interface nve1
[*Leaf1-Nve1] source 10.2.2.2
[*Leaf1-Nve1] vni 5010 head-end peer-list 10.1.1.1
```

```
[*Leaf1-Nve1] quit
[*Leaf1] commit
```

Configure Spine1.

```
[~Spine1] bridge-domain 10
[*Spine1-bd10] vxlan vni 5010
[*Spine1-bd10] quit
[*Spine1] interface nve1
[*Spine1-Nve1] source 10.1.1.1
[*Spine1-Nve1] vni 5010 head-end peer-list 10.2.2.2
[*Spine1-Nve1] quit
[*Spine1] commit
```

After the configuration is complete, run the **display vxlan vni** command on Spine1. The command output shows that the VNI status is **up**. Run the **display vxlan tunnel** command, and you can see VXLAN tunnel information.

```
[~Spine1] display vxlan vni
Number of vxlan vni : 1
VNI          BD-ID          State
-----
5010         10             up
[~Spine1] display vxlan tunnel
Number of vxlan tunnel : 1
Tunnel ID   Source          Destination     State  Type
-----
4026531841  10.1.1.1       10.2.2.2       up     static
```

Step 3 Create an Eth-Trunk and add physical Ethernet interfaces to the Eth-Trunk.

An uplink interface of a server connected to a switch needs to be bound to an aggregated link and the link aggregation mode of the server needs to be consistent with that of the switch.

Create an Eth-Trunk in LACP mode on Leaf1 and add physical Ethernet interfaces to the Eth-Trunk. The configuration on Leaf2 is similar to that on Leaf1, and is not mentioned here.

```
[~Leaf1] interface eth-trunk 1
[*Leaf1-Eth-Trunk1] mode lacp-static
[*Leaf1-Eth-Trunk1] trunkport 10ge 1/0/4 to 1/0/5
[*Leaf1-Eth-Trunk1] quit
[*Leaf1] interface eth-trunk 10
[*Leaf1-Eth-Trunk10] mode lacp-dynamic
[*Leaf1-Eth-Trunk10] trunkport 10ge 1/0/2 to 1/0/3
[*Leaf1-Eth-Trunk10] quit
[*Leaf1] commit
```

Step 4 Configure Leaf1 and Leaf2 as root bridges and configure the same bridge ID for them.

NOTE

If the two devices that constitute an M-LAG connect to downstream switching devices, you must configure root protection.

Configure Leaf1.

```
[~Leaf1] stp root primary
[*Leaf1] stp bridge-address 39-39-39
[*Leaf1] interface eth-trunk 10
[*Leaf1-Eth-Trunk10] stp edged-port enable
[*Leaf1-Eth-Trunk10] commit
[~Leaf1-Eth-Trunk10] quit
```

Configure Leaf2.

```
[~Leaf2] stp root primary
[*Leaf2] stp bridge-address 39-39-39
[*Leaf2] interface eth-trunk 10
[*Leaf2-Eth-Trunk10] stp edged-port enable
```

```
[*Leaf2-Eth-Trunk10] commit
[~Leaf2-Eth-Trunk10] quit
```

Step 5 Configure a DFS group on Leaf1 and Leaf2 respectively.

Configure Leaf1. The configuration on Leaf2 is similar to that on Leaf1, and is not mentioned here.

```
[~Leaf1] dfs-group 1
[*Leaf1-dfs-group-1] source ip 10.3.3.3
[*Leaf1-dfs-group-1] quit
[*Leaf1] commit
```

Step 6 Configure a link between Leaf1 and Leaf2 as the peer link.

Configure Leaf1. The configuration on Leaf2 is similar to that on Leaf1, and is not mentioned here.

```
[~Leaf1] interface eth-trunk 1
[~Leaf1-Eth-Trunk1] undo stp enable
[*Leaf1-Eth-Trunk1] peer-link 1
[*Leaf1-Eth-Trunk1] quit
[*Leaf1] commit
```

Step 7 Bind the user-side Eth-Trunk to the DFS group on Leaf1 and Leaf2.

Configure Leaf1. The configuration on Leaf2 is similar to that on Leaf1, and is not mentioned here.

```
[~Leaf1] interface eth-trunk 10
[~Leaf1-Eth-Trunk10] dfs-group 1 m-lag 1
[*Leaf1-Eth-Trunk10] quit
[*Leaf1] lacp m-lag priority 10
[*Leaf1] lacp m-lag system-id 00e0-fc00-0000
[*Leaf1] commit
```

Step 8 Configure service access points on Leaf1 and Leaf2.

Configure Leaf1. The configuration on Leaf2 is similar to that on Leaf1, and is not mentioned here.

```
[~Leaf1] vlan 10
[*Leaf1-vlan10] quit
[*Leaf1] bridge-domain 10
[*Leaf1-bd10] 12 binding vlan 10
[*Leaf1-bd10] quit
[*Leaf1] interface eth-trunk 10
[*Leaf1-Eth-Trunk10] port link-type trunk
[*Leaf1-Eth-Trunk10] undo port trunk allow-pass vlan 1
[*Leaf1-Eth-Trunk10] port trunk allow-pass vlan 10
[*Leaf1-Eth-Trunk10] quit
[*Leaf1] commit
```

Step 9 Verify the configuration.

Run the **display dfs-group 1 m-lag** command to check M-LAG information.

```
[~Leaf1] display dfs-group 1 m-lag
*
: Local node
Heart beat state : OK
Node 1 *
  Dfs-Group ID   : 1
  Priority       : 100
  Address        : ip address 10.3.3.3
  State         : Master
  Causation      : -
  System ID     : 0025-9e95-7c11
  SysName       : Leaf1
```

```

Version       : V100R006C00
Device Type   : CE7850EI
Node 2
Dfs-Group ID : 1
Priority      : 100
Address       : ip address 10.4.4.4
State        : Backup
Causation    : -
System ID    : 0025-9e95-7c31
SysName      : Leaf2
Version      : V100R006C00
Device Type   : CE7850EI
    
```

Check M-LAG information on Leaf1.

```

[~Leaf1] display dfs-group 1 node 1 m-lag brief
* - Local node

M-Lag ID      Interface      Port State      Status
-----
1             Eth-Trunk 10      Up              active(*)-active
    
```

Check M-LAG information on Leaf2.

```

[~Leaf2] display dfs-group 1 node 2 m-lag brief
* - Local node

M-Lag ID      Interface      Port State      Status
-----
1             Eth-Trunk 10      Up              active-active(*)
    
```

Run the **display bridge-domain 10 verbose** command on Leaf1 and Leaf2 to view BD information. The display on Leaf1 is taken as an example.

```

[~Leaf1] display bridge-domain 10 verbose
Bridge-domain ID      : 10
Description           :
State                 : Up
MAC Learning          : Enable
Statistics            : Disable
Broadcast             : Forward
Unknown-unicast       : Forward
Unknown-multicast     : Forward
Split-horizon         : Disable

-----
Interface              State
Eth-Trunk1.5010       up
10GE1/0/3.1           up
    
```

----End

Configuration Files

- Configuration file of Leaf1

```

#
sysname Leaf1
#
dfs-group 1
 source ip 10.3.3.3
#
vlan batch 10
#
stp bridge-address 0039-0039-0039
stp instance 0 root primary
#
lACP m-lag system-id 00e0-fc00-0000
lACP m-lag priority 10
#
bridge-domain 10
    
```

```
12 binding vlan 10
vxlan vni 5010
#
interface Eth-Trunk1
 stp disable
 mode lacp-static
 peer-link 1
#
interface Eth-Trunk10
 stp edged-port enable
 mode lacp-dynamic
 dfs-group 1 m-lag 1
#
interface Eth-Trunk10
 port link-type trunk
 undo port trunk allow-pass vlan 1
 port trunk allow-pass vlan 10
#
interface 10GE1/0/1
 undo portswitch
 ip address 192.168.1.1 255.255.255.0
#
interface 10GE1/0/2
 eth-trunk 10
#
interface 10GE1/0/3
 eth-trunk 10
#
interface 10GE1/0/4
 eth-trunk 1
#
interface 10GE1/0/5
 eth-trunk 1
#
interface LoopBack1
 ip address 10.2.2.2 255.255.255.255
#
interface LoopBack2
 ip address 10.3.3.3 255.255.255.255
#
interface Nve1
 source 10.2.2.2
 vni 5010 head-end peer-list 10.1.1.1
#
ospf 1
 area 0.0.0.0
 network 10.2.2.2 0.0.0.0
 network 10.3.3.3 0.0.0.0
 network 192.168.1.0 0.0.0.255
#
return
```

- Configuration file of Leaf2

```
#
sysname Leaf2
#
dfs-group 1
 source ip 10.4.4.4
#
vlan batch 10
#
stp bridge-address 0039-0039-0039
stp instance 0 root primary
#
lacp m-lag system-id 00e0-fc00-0000
lacp m-lag priority 10
#
bridge-domain 10
 12 binding vlan 10
 vxlan vni 5010
```



```
#
interface Eth-Trunk1
 stp disable
 mode lacp-static
 peer-link 1
#
interface Eth-Trunk10
 stp edged-port enable
 mode lacp-dynamic
 dfs-group 1 m-lag 1
#
interface Eth-Trunk10
 port link-type trunk
 undo port trunk allow-pass vlan 1
 port trunk allow-pass vlan 10
#
interface 10GE1/0/1
 undo portswitch
 ip address 192.168.2.1 255.255.255.0
#
interface 10GE1/0/2
 eth-trunk 10
#
interface 10GE1/0/3
 eth-trunk 10
#
interface 10GE1/0/4
 eth-trunk 1
#
interface 10GE1/0/5
 eth-trunk 1
#
interface LoopBack1
 ip address 10.2.2.2 255.255.255.255
#
interface LoopBack2
 ip address 10.4.4.4 255.255.255.255
#
interface Nve1
 source 10.2.2.2
 vni 5010 head-end peer-list 10.1.1.1
#
ospf 1
 area 0.0.0.0
 network 10.2.2.2 0.0.0.0
 network 10.4.4.4 0.0.0.0
 network 192.168.2.0 0.0.0.255
#
return
```

- Configuration file of Spine1

```
#
sysname Spine1
#
bridge-domain 10
 vxlan vni 5010
#
interface 10GE1/0/1
 undo portswitch
 ip address 192.168.1.2 255.255.255.0
#
interface 10GE1/0/2
 undo portswitch
 ip address 192.168.2.2 255.255.255.0
#
interface LoopBack1
 ip address 10.1.1.1 255.255.255.255
#
interface Nve1
 source 10.1.1.1
```

```
vni 5010 head-end peer-list 10.2.2.2
#
ospf 1
 area 0.0.0.0
  network 10.1.1.1 0.0.0.0
  network 192.168.1.0 0.0.0.255
  network 192.168.2.0 0.0.0.255
#
return
```

1.7.6 Example for Configuring Multi-level M-LAG Interconnection

Networking Requirements

The customer wants to build a stable large Layer 2 network so that a large number of servers can be deployed. The requirements are as follows:

- The dual-homing mode is used to ensure reliability.
- The load balancing mode is used to improve the link use efficiency.

As shown in [Figure 1-34](#), multi-level M-LAG interconnection ensures reliability, improves the link use efficiency, and expands the network scale in dual-homing mode, meeting customer requirements. Aggregation devices function as active-active gateways, and core and aggregation devices are connected in a crossover manner to ensure device-level reliability.

In this example, SwitchA, SwitchB, SwitchC, and SwitchD are CE8800&7800&6800&5800 series switches, and SwitchE, SwitchF, SwitchG, and SwitchH are CE12800 series switches. The CE12804 (modular switch) and CE6850EI (fixed switch) are used as examples.

Figure 1-34 Networking for configuring multi-level M-LAG interconnection

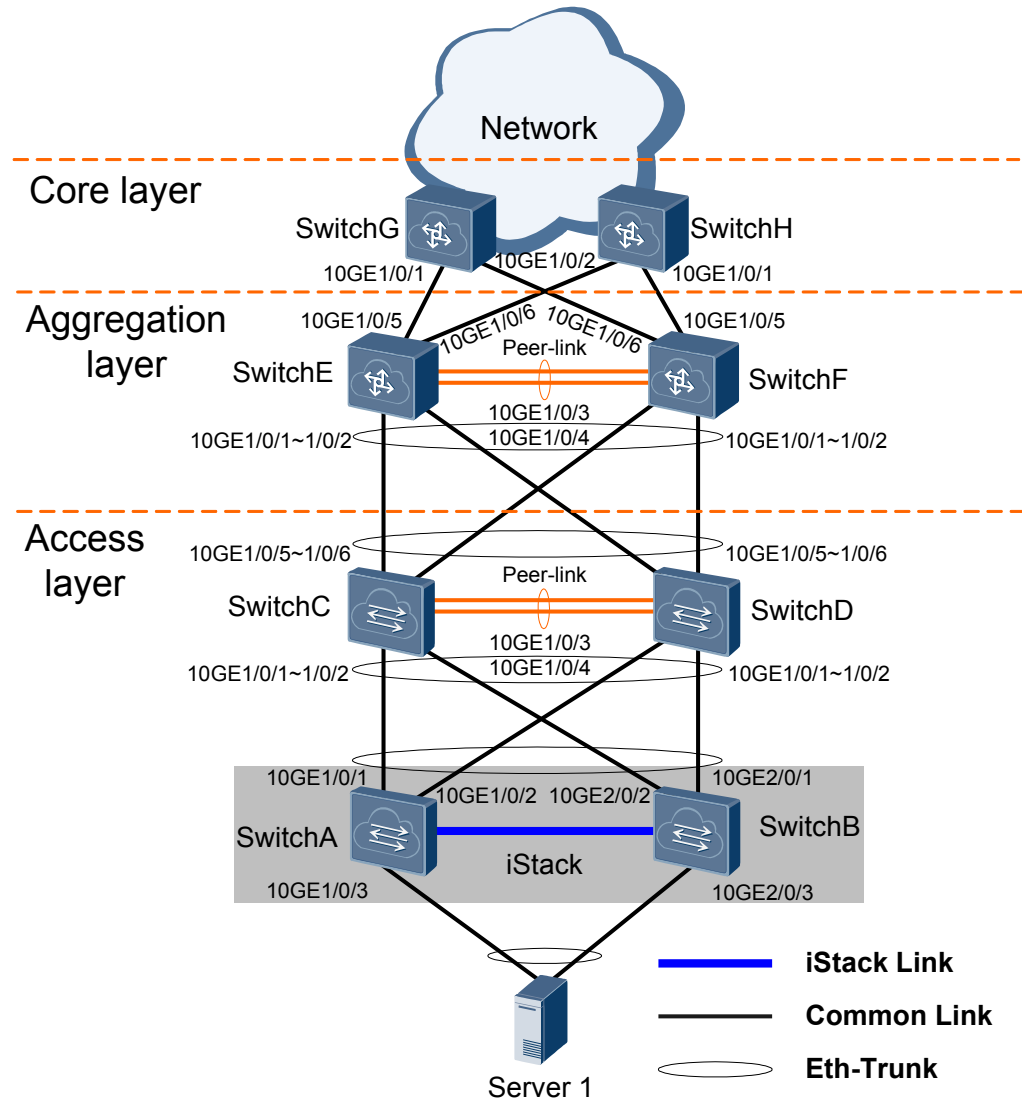

Data Plan

Device Name	Interface	IP Address	Virtual IP Address
SwitchC	Management interface	10.1.1.1/24	-
SwitchD	Management interface	10.1.1.2/24	-
SwitchE	Management interface	10.2.1.1/24	-
	VLANIF11	10.3.1.1/24	10.3.1.111
	10GE1/0/5	10.4.1.1/24	-
	10GE1/0/6	10.5.1.1/24	-

Device Name	Interface	IP Address	Virtual IP Address
SwitchF	Management interface	10.2.1.2/24	-
	VLANIF11	10.3.1.2/24	10.3.1.111
	10GE1/0/5	10.6.1.1/24	-
	10GE1/0/6	10.7.1.1/24	-
SwitchG	10GE1/0/1	10.4.1.2/24	-
	10GE1/0/2	10.7.1.2/24	-
SwitchH	10GE1/0/1	10.6.1.2/24	-
	10GE1/0/2	10.5.1.2/24	-

Configuration Roadmap

The configuration roadmap is as follows:

1. Configure SwitchA and SwitchB to form a stack to ensure high reliability of server access.
2. Add the link connecting Server 1 and the stack to the inter-chassis Eth-Trunk to improve the link bandwidth and reliability.
3. Configure the V-STP, DFS group, peer-link, and M-LAG on SwitchC, SwitchD, SwitchE, and SwitchF.
4. Configure the LACP M-LAG system priority and system ID on SwitchC, SwitchD, SwitchE, and SwitchF.
5. Create VLANIF interfaces on SwitchG and SwitchH and configure IP addresses for the VLANIF interfaces, and create VRRP groups on the VLANIF interfaces to implement gateway backup.
6. Enable OSPF on SwitchE, SwitchF, SwitchG, and SwitchH to implement Layer 3 connectivity.

NOTE

Perform the configuration in sequence strictly; configure the devices that constitute the M-LAG one by one; and ensure that the LACP mode is used.

Procedure

Step 1 Configure SwitchA and SwitchB to form a stack. For details, see Stack Configuration in Configuration Guide - Virtualization Configuration.

Step 2 Create an Eth-Trunk in the stack, add the Eth-Trunk to VLAN 11, and configure the Eth-Trunk to preferentially forward local traffic in the stack.

The uplink interface of the server connected to the stack needs to be bound to an aggregation link, and the link aggregation modes on the server and stack must be consistent.

```
<HUAWEI> system-view
[~HUAWEI] sysname iStack
```

```
[*HUAWEI] commit
[~iStack] vlan batch 11
[*iStack] interface eth-trunk 10
[*iStack-Eth-Trunk10] mode lacp-dynamic
[*iStack-Eth-Trunk10] port link-type access
[*iStack-Eth-Trunk10] port default vlan 11
[*iStack-Eth-Trunk10] trunkport 10ge 1/0/3
[*iStack-Eth-Trunk10] trunkport 10ge 2/0/3
[*iStack-Eth-Trunk10] undo local-preference disable
[*iStack-Eth-Trunk10] quit
[*iStack] interface eth-trunk 20
[*iStack-Eth-Trunk20] mode lacp-static
[*iStack-Eth-Trunk20] port link-type trunk
[*iStack-Eth-Trunk20] port trunk allow-pass vlan 11
[*iStack-Eth-Trunk20] trunkport 10ge 1/0/1
[*iStack-Eth-Trunk20] trunkport 10ge 1/0/2
[*iStack-Eth-Trunk20] trunkport 10ge 2/0/1
[*iStack-Eth-Trunk20] trunkport 10ge 2/0/2
[*iStack-Eth-Trunk20] quit
[*iStack] commit
```

Step 3 Configure the V-STP, DFS group, peer-link, and M-LAG on SwitchC, SwitchD, SwitchE, and SwitchF.

Configure SwitchC.

```
<HUAWEI> system-view
[~HUAWEI] sysname SwitchC
[*HUAWEI] commit
[~SwitchC] stp mode rstp
[*SwitchC] stp v-stp enable
[*SwitchC] interface meth 0/0/0
[*SwitchC-MEth0/0/0] ip address 10.1.1.1 24
[*SwitchC-MEth0/0/0] quit
[*SwitchC] dfs-group 1
[*SwitchC-dfs-group-1] source ip 10.1.1.1
[*SwitchC-dfs-group-1] priority 150
[*SwitchC-dfs-group-1] quit
[*SwitchC] interface eth-trunk 0
[*SwitchC-Eth-Trunk0] trunkport 10ge 1/0/3
[*SwitchC-Eth-Trunk0] trunkport 10ge 1/0/4
[*SwitchC-Eth-Trunk0] mode lacp-static
[*SwitchC-Eth-Trunk0] peer-link 1
[*SwitchC-Eth-Trunk0] quit
[*SwitchC] vlan batch 11
[*SwitchC] interface eth-trunk 20
[*SwitchC-Eth-Trunk20] mode lacp-static
[*SwitchC-Eth-Trunk20] port link-type trunk
[*SwitchC-Eth-Trunk20] port trunk allow-pass vlan 11
[*SwitchC-Eth-Trunk20] trunkport 10ge 1/0/1 to 1/0/2
[*SwitchC-Eth-Trunk20] dfs-group 1 m-lag 1
[*SwitchC-Eth-Trunk20] quit
[*SwitchC] interface eth-trunk 30
[*SwitchC-Eth-Trunk30] mode lacp-static
[*SwitchC-Eth-Trunk30] port link-type trunk
[*SwitchC-Eth-Trunk30] port trunk allow-pass vlan 11
[*SwitchC-Eth-Trunk30] trunkport 10ge 1/0/5 to 1/0/6
[*SwitchC-Eth-Trunk30] dfs-group 1 m-lag 2
[*SwitchC-Eth-Trunk30] quit
[*SwitchC] commit
```

Configure SwitchD.

```
<HUAWEI> system-view
[~HUAWEI] sysname SwitchD
[*HUAWEI] commit
[~SwitchD] stp mode rstp
[*SwitchD] stp v-stp enable
[*SwitchD] interface meth 0/0/0
[*SwitchD-MEth0/0/0] ip address 10.1.1.2 24
```

```
[*SwitchD-MEth0/0/0] quit
[*SwitchD] dfs-group 1
[*SwitchD-dfs-group-1] source ip 10.1.1.2
[*SwitchD-dfs-group-1] priority 120
[*SwitchD-dfs-group-1] quit
[*SwitchD] interface eth-trunk 0
[*SwitchD-Eth-Trunk0] trunkport 10ge 1/0/3
[*SwitchD-Eth-Trunk0] trunkport 10ge 1/0/4
[*SwitchD-Eth-Trunk0] mode lacp-static
[*SwitchD-Eth-Trunk0] peer-link 1
[*SwitchD-Eth-Trunk0] quit
[*SwitchD] vlan batch 11
[*SwitchD] interface eth-trunk 20
[*SwitchD-Eth-Trunk20] mode lacp-static
[*SwitchD-Eth-Trunk20] port link-type trunk
[*SwitchD-Eth-Trunk20] port trunk allow-pass vlan 11
[*SwitchD-Eth-Trunk20] trunkport 10ge 1/0/1 to 1/0/2
[*SwitchD-Eth-Trunk20] dfs-group 1 m-lag 1
[*SwitchD-Eth-Trunk20] quit
[*SwitchD] interface eth-trunk 30
[*SwitchD-Eth-Trunk30] mode lacp-static
[*SwitchD-Eth-Trunk30] port link-type trunk
[*SwitchD-Eth-Trunk30] port trunk allow-pass vlan 11
[*SwitchD-Eth-Trunk30] trunkport 10ge 1/0/5 to 1/0/6
[*SwitchD-Eth-Trunk30] dfs-group 1 m-lag 2
[*SwitchD-Eth-Trunk30] quit
[*SwitchD] commit
```

Configure SwitchE.

```
<HUAWEI> system-view
[~HUAWEI] sysname SwitchE
[*HUAWEI] commit
[~SwitchE] stp mode rstp
[*SwitchE] stp v-stp enable
[*SwitchE] interface meth 0/0/0
[*SwitchE-MEth0/0/0] ip address 10.2.1.1 24
[*SwitchE-MEth0/0/0] quit
[*SwitchE] dfs-group 1
[*SwitchE-dfs-group-1] source ip 10.2.1.1
[*SwitchE-dfs-group-1] priority 150
[*SwitchE-dfs-group-1] quit
[*SwitchE] interface eth-trunk 0
[*SwitchE-Eth-Trunk0] trunkport 10ge 1/0/3
[*SwitchE-Eth-Trunk0] trunkport 10ge 1/0/4
[*SwitchE-Eth-Trunk0] mode lacp-static
[*SwitchE-Eth-Trunk0] peer-link 1
[*SwitchE-Eth-Trunk0] quit
[*SwitchE] vlan batch 11
[*SwitchE] interface eth-trunk 40
[*SwitchE-Eth-Trunk40] mode lacp-static
[*SwitchE-Eth-Trunk40] port link-type trunk
[*SwitchE-Eth-Trunk40] port trunk allow-pass vlan 11
[*SwitchE-Eth-Trunk40] trunkport 10ge 1/0/1 to 1/0/2
[*SwitchE-Eth-Trunk40] dfs-group 1 m-lag 1
[*SwitchE-Eth-Trunk40] quit
[*SwitchE] commit
```

Configure SwitchF.

```
<HUAWEI> system-view
[~HUAWEI] sysname SwitchF
[*HUAWEI] commit
[~SwitchF] stp mode rstp
[*SwitchF] stp v-stp enable
[*SwitchF] interface meth 0/0/0
[*SwitchF-MEth0/0/0] ip address 10.2.1.2 24
[*SwitchF-MEth0/0/0] quit
[*SwitchF] dfs-group 1
[*SwitchF-dfs-group-1] source ip 10.2.1.2
```

```
[*SwitchF-dfs-group-1] priority 120
[*SwitchF-dfs-group-1] quit
[*SwitchF] interface eth-trunk 0
[*SwitchF-Eth-Trunk0] trunkport 10ge 1/0/3
[*SwitchF-Eth-Trunk0] trunkport 10ge 1/0/4
[*SwitchF-Eth-Trunk0] mode lacp-static
[*SwitchF-Eth-Trunk0] peer-link 1
[*SwitchF-Eth-Trunk0] quit
[*SwitchF] vlan batch 11
[*SwitchF] interface eth-trunk 40
[*SwitchF-Eth-Trunk40] mode lacp-static
[*SwitchF-Eth-Trunk40] port link-type trunk
[*SwitchF-Eth-Trunk40] port trunk allow-pass vlan 11
[*SwitchF-Eth-Trunk40] trunkport 10ge 1/0/1 to 1/0/2
[*SwitchF-Eth-Trunk40] dfs-group 1 m-lag 1
[*SwitchF-Eth-Trunk40] quit
[*SwitchF] commit
```

Step 4 Configure the LACP M-LAG system priority and system ID on SwitchC, SwitchD, SwitchE, and SwitchF.

Configure SwitchC.

```
[~SwitchC] lacp m-lag priority 10
[*SwitchC] lacp m-lag system-id 00e0-fc00-0000
[*SwitchC] commit
```

Configure SwitchD.

```
[~SwitchD] lacp m-lag priority 10
[*SwitchD] lacp m-lag system-id 00e0-fc00-0000
[*SwitchD] commit
```

Configure SwitchE.

```
[~SwitchE] lacp m-lag priority 10
[*SwitchE] lacp m-lag system-id 00e0-fc00-0001
[*SwitchE] commit
```

Configure SwitchF.

```
[~SwitchF] lacp m-lag priority 10
[*SwitchF] lacp m-lag system-id 00e0-fc00-0001
[*SwitchF] commit
```

Step 5 Create VLANIF interfaces on SwitchE and SwitchF and configure IP addresses for the VLANIF interfaces, and create VRRP groups on the VLANIF interfaces.

Configure SwitchE.

```
[~SwitchE] interface vlanif 11
[*SwitchE-Vlanif11] ip address 10.3.1.1 24
[*SwitchE-Vlanif11] vrrp vrid 1 virtual-ip 10.3.1.111
[*SwitchE-Vlanif11] quit
[*SwitchE] commit
```

Configure SwitchF.

```
[~SwitchF] interface vlanif 11
[*SwitchF-Vlanif11] ip address 10.3.1.2 24
[*SwitchF-Vlanif11] vrrp vrid 1 virtual-ip 10.3.1.111
[*SwitchF-Vlanif11] quit
[*SwitchF] commit
```

Step 6 Enable OSPF on SwitchE, SwitchF, SwitchG, and SwitchH.

Configure SwitchE.

```
[~SwitchE] interface 10ge 1/0/5
[*SwitchE-10GE1/0/5] undo portswitch
[*SwitchE-10GE1/0/5] ip address 10.4.1.1 24
[*SwitchE-10GE1/0/5] quit
[*SwitchE] interface 10ge 1/0/6
```

```
[*SwitchE-10GE1/0/6] undo portswitch
[*SwitchE-10GE1/0/6] ip address 10.5.1.1 24
[*SwitchE-10GE1/0/6] quit
[*SwitchE] ospf 1
[*SwitchE-ospf-1] area 0
[*SwitchE-ospf-1-area-0.0.0.0] network 10.3.1.0 0.0.0.255
[*SwitchE-ospf-1-area-0.0.0.0] network 10.4.1.0 0.0.0.255
[*SwitchE-ospf-1-area-0.0.0.0] network 10.5.1.0 0.0.0.255
[*SwitchE-ospf-1-area-0.0.0.0] quit
[*SwitchE-ospf-1] quit
[*SwitchE] commit
```

Configure SwitchF.

```
[~SwitchF] interface 10ge 1/0/5
[*SwitchF-10GE1/0/5] undo portswitch
[*SwitchF-10GE1/0/5] ip address 10.6.1.1 24
[*SwitchF-10GE1/0/5] quit
[*SwitchF] interface 10ge 1/0/6
[*SwitchF-10GE1/0/6] undo portswitch
[*SwitchF-10GE1/0/6] ip address 10.7.1.1 24
[*SwitchF-10GE1/0/6] quit
[*SwitchF] ospf 1
[*SwitchF-ospf-1] area 0
[*SwitchF-ospf-1-area-0.0.0.0] network 10.3.1.0 0.0.0.255
[*SwitchF-ospf-1-area-0.0.0.0] network 10.6.1.0 0.0.0.255
[*SwitchF-ospf-1-area-0.0.0.0] network 10.7.1.0 0.0.0.255
[*SwitchF-ospf-1-area-0.0.0.0] quit
[*SwitchF-ospf-1] quit
[*SwitchF] commit
```

Configure SwitchG.

```
<HUAWEI> system-view
[~HUAWEI] sysname SwitchG
[*HUAWEI] commit
[~SwitchG] interface 10ge 1/0/1
[*SwitchG-10GE1/0/1] undo portswitch
[*SwitchG-10GE1/0/1] ip address 10.4.1.2 24
[*SwitchG-10GE1/0/1] quit
[*SwitchG] interface 10ge 1/0/2
[*SwitchG-10GE1/0/2] undo portswitch
[*SwitchG-10GE1/0/2] ip address 10.7.1.2 24
[*SwitchG-10GE1/0/2] quit
[*SwitchG] ospf 1
[*SwitchG-ospf-1] area 0
[*SwitchG-ospf-1-area-0.0.0.0] network 10.4.1.0 0.0.0.255
[*SwitchG-ospf-1-area-0.0.0.0] network 10.7.1.0 0.0.0.255
[*SwitchG-ospf-1-area-0.0.0.0] quit
[*SwitchG-ospf-1] quit
[*SwitchG] commit
```

Configure SwitchH.

```
<HUAWEI> system-view
[~HUAWEI] sysname SwitchH
[*HUAWEI] commit
[~SwitchH] interface 10ge 1/0/1
[*SwitchH-10GE1/0/1] undo portswitch
[*SwitchH-10GE1/0/1] ip address 10.6.1.2 24
[*SwitchH-10GE1/0/1] quit
[*SwitchH] interface 10ge 1/0/2
[*SwitchH-10GE1/0/2] undo portswitch
[*SwitchH-10GE1/0/2] ip address 10.5.1.2 24
[*SwitchH-10GE1/0/2] quit
[*SwitchH] ospf 1
[*SwitchH-ospf-1] area 0
[*SwitchH-ospf-1-area-0.0.0.0] network 10.5.1.0 0.0.0.255
[*SwitchH-ospf-1-area-0.0.0.0] network 10.6.1.0 0.0.0.255
[*SwitchH-ospf-1-area-0.0.0.0] quit
```



```
[*SwitchH-ospf-1] quit
[*SwitchH] commit
```

Step 7 Verify the configuration.

- Run the **display dfs-group** command to check M-LAG information.

Check DFS group information.

```
[~SwitchC] display dfs-group 1 m-lag
*          : Local node
Heart beat state : OK
Node 1 *
  Dfs-Group ID   : 1
  Priority        : 150
  Address         : ip address 10.1.1.1
  State          : Master
  Causation      : -
  System ID      : 0025-9e95-7c31
  SysName        : SwitchC
  Version        : V100R006C00
  Device Type    : CE6850EI
Node 2
  Dfs-Group ID   : 1
  Priority        : 120
  Address         : ip address 10.1.1.2
  State          : Backup
  Causation      : -
  System ID      : 0025-9e95-7c11
  SysName        : SwitchD
  Version        : V100R006C00
  Device Type    : CE6850EI
[~SwitchE] display dfs-group 1 m-lag
*          : Local node
Heart beat state : OK
Node 1 *
  Dfs-Group ID   : 1
  Priority        : 150
  Address         : ip address 10.2.1.1
  State          : Master
  Causation      : -
  System ID      : 0025-9e95-7c41
  SysName        : SwitchE
  Version        : V100R006C00
  Device Type    : CE12800
Node 2
  Dfs-Group ID   : 1
  Priority        : 120
  Address         : ip address 10.2.1.2
  State          : Backup
  Causation      : -
  System ID      : 0025-9e95-7c21
  SysName        : SwitchF
  Version        : V100R006C00
  Device Type    : CE12800
```

Check M-LAG information on SwitchC.

```
[~SwitchC] display dfs-group 1 node 1 m-lag brief
* - Local node

M-Lag ID   Interface      Port State   Status
-----
1          Eth-Trunk 20   Up          active(*)-active
2          Eth-Trunk 30   Up          active(*)-active
```

Check M-LAG information on SwitchE.

```
[~SwitchE] display dfs-group 1 node 2 m-lag brief
* - Local node

M-Lag ID   Interface      Port State   Status
-----
1          Eth-Trunk 40   Up          active-active(*)
```

In the preceding information, the value of **Heart beat state** is **OK**, indicating that the heartbeat is normal. SwitchC and SwitchE are used as Node 1, its priority is 150, and the value of **State** is **Master**. SwitchD and SwitchF are used as Node 2, the priority is 120, and the value of **State** is **Backup**. The value of **Causation** is -, the values of **Port State** of Node 1 and Node 2 are both **Up**, and the M-LAG status of both Node 1 and Node 2 is **active**, indicating that the M-LAG configuration is correct.

- Run the **display vrrp** command on SwitchG and SwitchH. You can see that SwitchG and SwitchH are in Master state.

```
[~SwitchG] display vrrp verbose
Vlanif11 | Virtual Router 1
State           : Master
Virtual IP      : 10.3.1.111
Master IP       : 10.3.1.1
PriorityRun     : 100
PriorityConfig  : 100
MasterPriority  : 100
Preempt        : YES    Delay Time : 0s    Remain : --
TimerRun       :
1s
TimerConfig    : 1s
Auth Type      :
NONE
Virtual MAC    :
0000-5e00-0101
Check TTL      :
YES
Config Type    : Normal
Create Time    : 2015-03-20
11:39:18
Last Change Time : 2015-03-25 11:38:58
[~SwitchH] display vrrp verbose
Vlanif11 | Virtual Router 1
State           : Master
Virtual IP      : 10.3.1.111
Master IP       : 10.3.1.1
PriorityRun     : 100
PriorityConfig  : 100
MasterPriority  : 120
Preempt        : YES    Delay Time : 0s    Remain : --
TimerRun       : 1s
TimerConfig    : 1s
Auth Type      : NONE
Virtual MAC    : 0000-5e00-0101
Check TTL      : YES
Config Type    : Normal
Create Time    : 2015-03-20 11:39:18
Last Change Time : 2015-03-25 11:38:58
```

----End

Configuration Files

- Stack configuration file

```
#
sysname iStack
#
vlan batch 11
#
stack
#
stack member 1 domain 10
stack member 1 priority 150
#
stack member 2 domain 10
#
```

```
interface Stack-Port1/1
#
interface Stack-Port2/1
#
interface Eth-Trunk10
port default vlan 11
mode lacp-dynamic
#
interface Eth-Trunk20
port link-type trunk
port trunk allow-pass vlan 11
mode lacp-static
#
interface 10GE1/0/1
eth-trunk 20
#
interface 10GE1/0/2
eth-trunk 20
#
interface 10GE1/0/3
eth-trunk 10
#
interface 40GE1/0/1
port mode stack
stack-port 1/1
#
interface 40GE1/0/2
port mode stack
stack-port 1/1
#
interface 10GE2/0/1
eth-trunk 20
#
interface 10GE2/0/2
eth-trunk 20
#
interface 10GE2/0/3
eth-trunk 10
#
interface 40GE2/0/1
port mode stack
stack-port 2/1
#
interface 40GE2/0/2
port mode stack
stack-port 2/1
#
return
```

- SwitchC configuration file

```
#
sysname SwitchC
#
dfs-group 1
priority 150
source ip 10.1.1.1
#
vlan batch 11
#
stp v-stp enable
stp mode rstp
#
lacp m-lag system-id 00e0-fc00-0000
lacp m-lag priority 10
#
interface MEth0/0/0
ip address 10.1.1.1 255.255.255.0
#
interface Eth-Trunk0
mode lacp-static
```

```
peer-link 1
#
interface Eth-Trunk20
port link-type trunk
port trunk allow-pass vlan 11
mode lacp-static
dfs-group 1 m-lag 1
#
interface Eth-Trunk30
port link-type trunk
port trunk allow-pass vlan 11
mode lacp-static
dfs-group 1 m-lag 2
#
interface 10GE1/0/1
eth-trunk 20
#
interface 10GE1/0/2
eth-trunk 20
#
interface 10GE1/0/3
eth-trunk 0
#
interface 10GE1/0/4
eth-trunk 0
#
interface 10GE1/0/5
eth-trunk 30
#
interface 10GE1/0/6
eth-trunk 30
#
return
```

● SwitchD configuration file

```
#
sysname SwitchD
#
dfs-group 1
priority 120
source ip 10.1.1.2
#
vlan batch 11
#
stp v-stp enable
stp mode rstp
#
lacp m-lag system-id 00e0-fc00-0000
lacp m-lag priority 10
#
interface MEth0/0/0
ip address 10.1.1.2 255.255.255.0
#
interface Eth-Trunk0
mode lacp-static
peer-link 1
#
interface Eth-Trunk20
port link-type trunk
port trunk allow-pass vlan 11
mode lacp-static
dfs-group 1 m-lag 1
#
interface Eth-Trunk30
port link-type trunk
port trunk allow-pass vlan 11
mode lacp-static
dfs-group 1 m-lag 2
#
interface 10GE1/0/1
```

```
eth-trunk 20
#
interface 10GE1/0/2
eth-trunk 20
#
interface 10GE1/0/3
eth-trunk 0
#
interface 10GE1/0/4
eth-trunk 0
#
interface 10GE1/0/5
eth-trunk 30
#
interface 10GE1/0/6
eth-trunk 30
#
return
```

- SwitchE configuration file

```
#
sysname SwitchE
#
dfs-group 1
priority 150
source ip 10.2.1.1
#
vlan batch 11
#
stp mode rstp
stp v-stp enable
#
lACP m-lag system-id 00e0-fc00-0001
lACP m-lag priority 10
#
interface Vlanif11
ip address 10.3.1.1 255.255.255.0
vrrp vrid 1 virtual-ip 10.3.1.111
#
interface MEth0/0/0
ip address 10.2.1.1 255.255.255.0
#
interface Eth-Trunk0
mode lACP-static
peer-link 1
#
interface Eth-Trunk40
port link-type trunk
port trunk allow-pass vlan 11
mode lACP-static
dfs-group 1 m-lag 1
#
interface 10GE1/0/1
eth-trunk 40
#
interface 10GE1/0/2
eth-trunk 40
#
interface 10GE1/0/3
eth-trunk 0
#
interface 10GE1/0/4
eth-trunk 0
#
interface 10GE1/0/5
undo portswitch
ip address 10.4.1.1 255.255.255.0
#
interface 10GE1/0/6
undo portswitch
```

```
ip address 10.5.1.1 255.255.255.0
#
ospf 1
 area 0.0.0.0
  network 10.3.1.0 0.0.0.255
  network 10.4.1.0 0.0.0.255
  network 10.5.1.0 0.0.0.255
#
return
```

● SwitchF configuration file

```
#
sysname SwitchF
#
dfs-group 1
 priority 120
 source ip 10.2.1.2
#
vlan batch 11
#
stp mode rstp
stp v-stp enable
#
lACP m-lag system-id 00e0-fc00-0001
lACP m-lag priority 10
#
interface Vlanif11
 ip address 10.3.1.2 255.255.255.0
 vrrp vrid 1 virtual-ip 10.3.1.111
#
interface MEth0/0/0
 ip address 10.2.1.2 255.255.255.0
#
interface Eth-Trunk0
 mode lACP-static
 peer-link 1
#
interface Eth-Trunk40
 port link-type trunk
 port trunk allow-pass vlan 11
 mode lACP-static
 dfs-group 1 m-lag 1
#
interface 10GE1/0/1
 eth-trunk 40
#
interface 10GE1/0/2
 eth-trunk 40
#
interface 10GE1/0/3
 eth-trunk 0
#
interface 10GE1/0/4
 eth-trunk 0
#
interface 10GE1/0/5
 undo portswitch
 ip address 10.6.1.1 255.255.255.0
#
interface 10GE1/0/6
 undo portswitch
 ip address 10.7.1.1 255.255.255.0
#
ospf 1
 area 0.0.0.0
  network 10.3.1.0 0.0.0.255
  network 10.6.1.0 0.0.0.255
  network 10.7.1.0 0.0.0.255
#
return
```

- SwitchG configuration file

```
#
sysname SwitchG
#
interface 10GE1/0/1
undo portswitch
ip address 10.4.1.2 255.255.255.0
#
interface 10GE1/0/2
undo portswitch
ip address 10.7.1.2 255.255.255.0
#
ospf 1
area 0.0.0.0
network 10.4.1.0 0.0.0.255
network 10.7.1.0 0.0.0.255
#
return
```

- SwitchH configuration file

```
#
sysname SwitchH
#
interface 10GE1/0/1
undo portswitch
ip address 10.6.1.2 255.255.255.0
#
interface 10GE1/0/2
undo portswitch
ip address 10.5.1.2 255.255.255.0
#
ospf 1
area 0.0.0.0
network 10.5.1.0 0.0.0.255
network 10.6.1.0 0.0.0.255
#
return
```