

# Embedded Power System

ETP48120-B5A2



## Introduction

ETP48120-B5A2 is an AC/DC embedded power system with excellent performance such as high power efficiency, intelligent battery management, remote management, wide range of AC input voltage, etc.

The system can configure 4 pieces of 1U 30A high rectifier modules, and provides 120A rated current output.

ETP48120-B5A2 can be embedded in 19-inch rack or cabinet.



ETP48120-B5A2

## Features

- 1U rectifier: high density, high efficiency (> 96%), excellent high temperature performance (fully output below 55°C)
- Wide operation temperature range of embedded power from – 40°C to 65°C
- Hot-swappable
- Standard structure design, adapt 19/21 inch installation
- Compact design(only 5U in height), saving user space
- Excellent rectifier dormancy function increases system efficiency
- Intelligent battery management and protection help to prolong battery lifespan
- Support environmental signal monitoring and remote management through dry contact, serial interface or Ethernet interface



30A rectifier



Controller

## Scenarios

- Wireless base station
- Transmission network
- Communication network of enterprises

# Efficiency Curve



Rectifier -1600 W-96%  
(R4830G1)

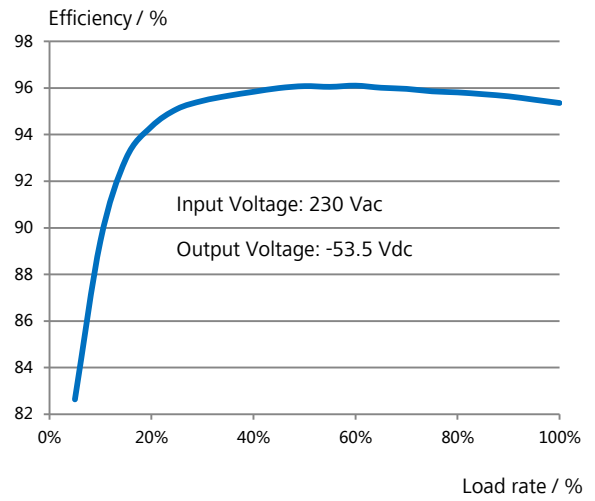

Energy Efficiency Curve



Rectifier -1740 W-94%  
(R4830N2)

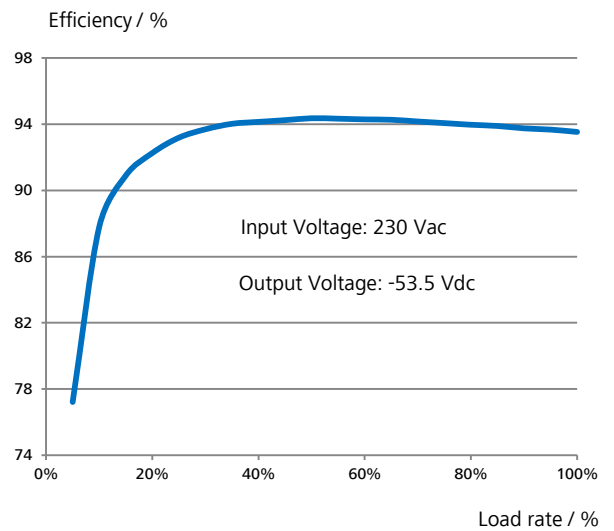

Energy Efficiency Curve

## Dimension Drawings

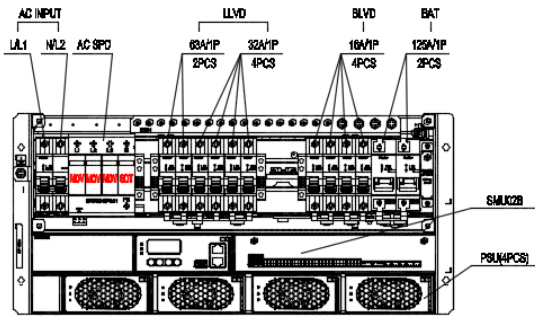

Front View of ETP48120-B5A2

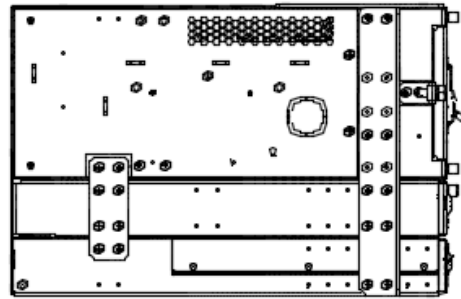

Side View of ETP48120-B5A2

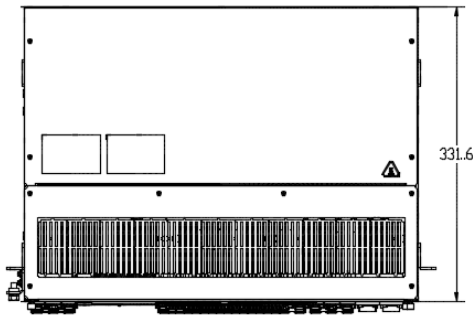

Top View of ETP48120-B5A2

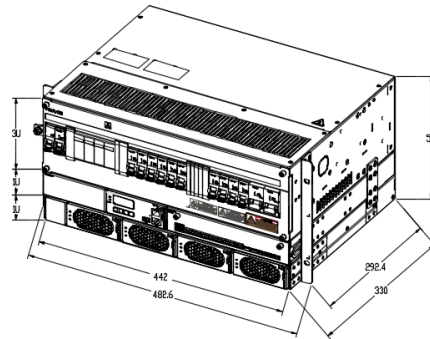

Overview of ETP48120-B5A2

## Schematic Diagram

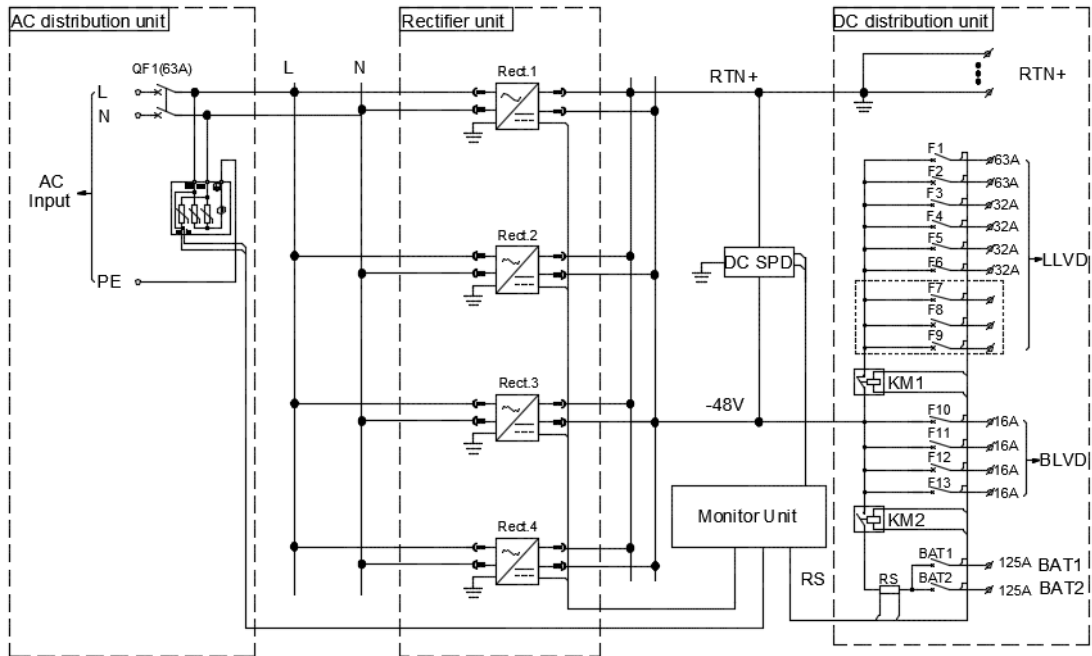

ETP48120-B5A2

## Specifications

Product Type		ETP48120-B5A2
System	Dimension	482.6 mm (W) × 330 mm (D) × 219.5 mm (5U,H)
	Weight	≤ 20 kg (without rectifiers)
	Cooling Mode	Natural cooling
	Installation Mode	Installed on 19-inch rack or cabinet
	Cabling Mode	Top inlet and top outlet
	Maintenance Mode	Front
	Protection Level	IP20
Input	AC Input Voltage	85–300 Vac, rated value: 220 Vac, 220 Vac single phase or 110 Vac dual-live wire
	Input Frequency	45–66 Hz, rated value: 50/60 Hz
	Input Capacity	1 × 63 A/2P
Output	AC Output	-
	Output Voltage	42–58 Vdc, rated value: 53.5 Vdc
	Maximum Capacity	6960 W
	Battery Breakers	2 × 125 A/1P
	LLVD Breakers	2 × 63 A/1P, 4 × 32 A/1P
	BLVD Breakers	4 × 16 A/1P
	SPD	20/40 kA, 8/20 μs (AC) , 10/20 kA, 8/20 μs (DC)
EMC & Safety	EMC	EN 55022, IEC 61000-3-3, IEC 61000-3-12, EN61000-4-2, EN61000-4-3, EN61000-4-4, EN61000-4-5, EN61000-4-6, EN61000-4-11
	Safety	IEC/EN60950-1 and GB4943
Environment	Operating Temperature	–40°C to +65°C
	Storage Temperature	–40°C to +70°C
	Operating Humidity	5% – 95% (non-condensing)
	Altitude	0 – 4000 m (When the altitude ranges from 2000 m to 4000 m, the operating temperature decreases by 1°C for each additional 200 m.)

Product Type		R4830G1	R4830N2
Rectifier	Efficiency	> 95% (25% to 100% load) > 96% Max	> 93% (30% to 100% load) > 94% Max
	Maximum Power	1600W (176 to 300 Vac)	1740W (176 to 300 Vac)
	Input Voltage	85 to 300 Vac / 85 to 400 Vdc	85 to 300 Vac
	Working Temperature	-40 °C to +75 °C (full output below 55°C), ETS EN 300-019	-40 °C to +75 °C (full output below 45°C), ETS EN 300-019
	Dimension	95.5 mm(W) × 208 mm(D) × 40.8 mm(H)	
	Weight	≤1.2 kg	≤1.3 kg
	Cooling Mode	Forced Air cooling (Built-in fan)	
	Power Factor	≥ 0.99 (> 50% load at 230 Vac)	≥ 0.98 (> 50% load at 230 Vac), ≥ 0.99 ( 100% load at 230 Vac )
	THD	≤ 5% (> 50% load at 230 Vac)	

Product Type		SMU02B
Controller	Signal Input	6 digital inputs (need interface Unit UIM02C), 7 analog inputs (need interface Unit UIM02C)
	Alarm Output	8 dry contacts (need interface Unit UIM02C)
	Communication Port	RS232, RS485, FE
	Display Mode	LCD

Copyright © Huawei Technologies Co., Ltd. 2016. All rights reserved.

No part of this document may be reproduced or transmitted in any form or by any means without prior written consent of Huawei Technologies Co., Ltd.

### General Disclaimer

The information in this document may contain predictive statements including, without limitation, statements regarding the future financial and operating results, future product portfolio, new technology, etc. There are a number of factors that could cause actual results and developments to differ materially from those expressed or implied in the predictive statements. Therefore, such information is provided for reference purpose only and constitutes neither an offer nor an acceptance. Huawei may change the information at any time without notice.

HUAWEI TECHNOLOGIES CO., LTD.

Huawei Industrial Base

Bantian Longgang

Shenzhen 518129, P.R. China

Tel: +86-755-28780808

www.huawei.com