



WAN Interconnection Solution for Large Enterprises



Huawei NE routers: Empowering your network

Challenges

Large-scale enterprises require complex network architectures to handle numerous branch offices and a variety of services. This adds to the complications of Wide Area Networks (WANs) and O&M. Nevertheless, the rapid growth of enterprise network services causes enterprise digital operations and network cloudification to gain momentum. As a result, large-enterprise WANs face the following challenges:

1 How to manage complex O&M networks?

- ◆ Large-enterprises have a large network scale, complex architecture, and various types of different services, complicating network management and O&M
- ◆ The technical skills of enterprise network administrators may need to be improved to ensure they are competent at maintaining such complex networks
- ◆ Complex services, worn devices, and private protocols deployed on a live network make fast service deployment impossible



2 How to guarantee key services?

- ◆ Key enterprise services, such as HD video conferencing and video surveillance, require high network bandwidth, high reliability, and low latency
- ◆ Non-key enterprise network services are diversified, and consume a large amount of bandwidth. Consequently, the bandwidth of key services cannot be guaranteed.



3 How to optimize traffic?

- ◆ A large enterprise with many branch offices requires a large number of leased lines and high bandwidth. Link cost is high, but link usage is low
- ◆ Traffic management and optimization policies based on traditional routes are not flexible enough to provide dynamic network optimization

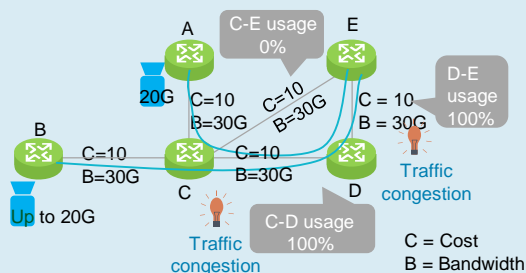

4 How to visualize a network?

- ◆ It is difficult to identify the root cause and demarcate a network fault, and even more difficult to locate the specific faulty network device
- ◆ Without precise traffic monitoring techniques and application awareness, refined network O&M is not possible.



Automated configuration management



Visualized O&M

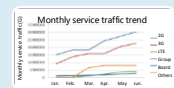

IP flow performance monitoring



Fast fault demarcation and diagnosis

Solution

Huawei's WAN Interconnection Solution helps enterprise users build high-bandwidth, high-reliability, low-cost, O&M-friendly, and future-oriented enterprise WANs.

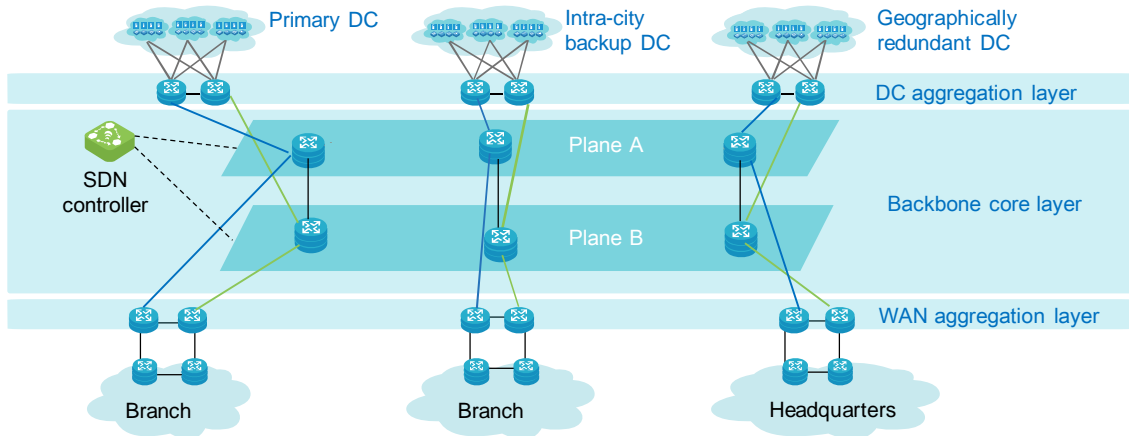

- ◆ Network architecture: Access (branch), aggregation, and core networking architecture is adopted, with the data center as the core. An end-to-end MPLS network is deployed.
- ◆ Global SDN management and control tunnel: RSVP-TE tunnels at the transmission layer and global SDN management and control ensure network stability and reliability. In addition, segment routing (SR)-based SDN management and control can be deployed to implement a light load on the control plane to increase flexibility and reliability.
- ◆ Dynamic traffic optimization: Fast traffic optimization is based on devices, links, and bandwidth that improves link usage. Traffic optimization also can be manually triggered, which is a more secure method.
- ◆ Automated VPN provisioning: MPLS VPN is used to isolate E2E services, and SDN is used to roll out automated VPN services.
- ◆ In-depth Network visualization: uTraffic multi-layer monitoring at the physical, network, device, and service levels.

Benefits

Key service guarantees

- ◆ E2E HQoS and large buffer guarantee key services.
- ◆ Bandwidth and low latency are ensured, and key service experience is enhanced.

Automated deployment and simplified O&M

- ◆ Devices are plug-and-play and go online quickly.
- ◆ SDN ensures that leased-line services are deployed and adjusted on demand. This process is both automatic and fast.
- ◆ SDN enables automated traffic optimization.

Super-visualized network management

- ◆ Integrated GUI permits unified management and O&M.
- ◆ Multi-level monitoring and quality analysis for fast fault location.

Large capacity and high reliability for network evolution

- ◆ Large-capacity, high-cache routers ensure sufficient network capacity.
- ◆ Dual-plane networking and highly reliable devices ensure network reliability.

Key Technologies

NP architecture and smart devices

- ◆ The large buffer of NE routers effectively copes with burst traffic on the network and ensures provisioning of key services such as videos
- ◆ Supports five-level HQoS scheduling
- ◆ The 16-nm chip on the NE router lowers power consumption
- ◆ With ultra-high reliability and ultra-low failure rate, NE routers have been put into commercial use in many large enterprises

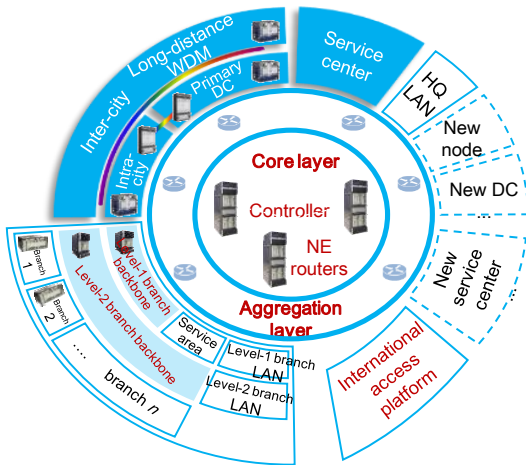

Multi-layer super-visualization

In-depth network analysis from the physical layer to the application layer enables network and device status to be collected in seconds. This cloudification of all network resources, with the help of SDN, provides intelligent O&M and network adjustments.

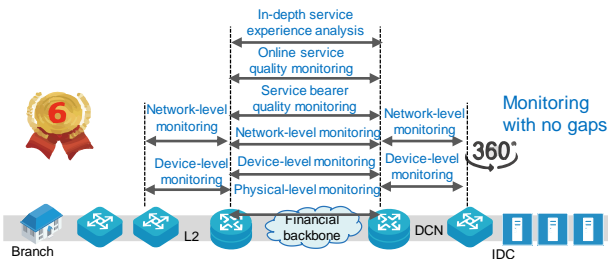

Traffic optimization

- ❖ Globally calculates forwarding paths
- ❖ Supports RSVP-TE and SR
- ❖ Computes paths based on traffic volume, link bandwidth, delay, and cost to improve network-wide bandwidth usage
- ❖ Prevents network burst congestion, ensures optimal service SLA, and intelligent maintenance

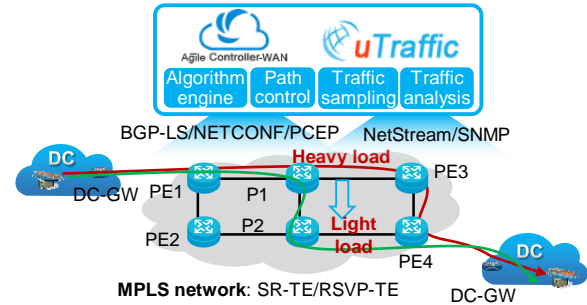

Self-service provisioning of all services

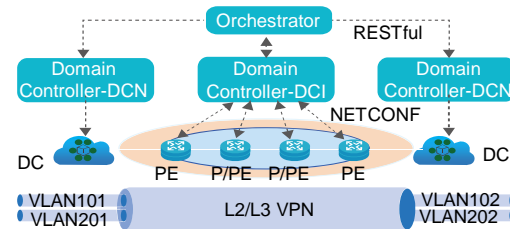

Unified GUI and automated L2/L3 service delivery enable creation of DCI VPNs, service VPNs, bandwidth on-demand route selection, service SLA selection, DCI service path visualization, and dynamic DCI service optimization.

Five-level HQoS scheduling

Five-level HQoS and differentiated services

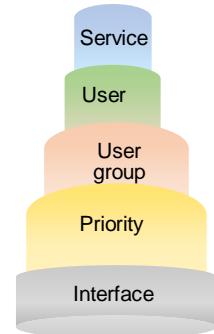

Recommended Products

NE40E Series Service Routers



NE40E-X3



NE40E-X3A

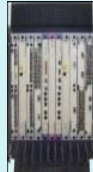

NE40E-X8



NE40E-X8A



NE40E-X16



NE40E-X16A

NE20E Series Service Routers



NE20E-S2E/S2F



NE20E-S4



NE20E-S8



NE20E-S8A



NE20E-S16



NE20E-S16A

Product Highlights

Highly reliable architecture

- ◆ Redundant main control boards, switch fabrics, power supplies, and fans
- ◆ Hot-swap and hot-standby for all key components
- ◆ CPU + NP architecture, control-forwarding separation

Huawei-designed chipset

- ◆ Solar 5.0 chipset developed in-house: extensible products and features and controllable evolution
- ◆ New 16-nm technology reduces power consumption per unit
- ◆ Chip-based BFD, with the 3.3-ms packet-sending interval and large-scale detection, link protection switching time ≤ 50 ms

Protection in all scenarios

- ◆ Fast reroute (FRR)
- ◆ VPN service E2E isolation
- ◆ E2E switchover within 200 ms with BFD, FRR, and TE hot standby

Industrial-grade design

- ◆ Dynamic energy-saving design
- ◆ Environmentally friendly with low-carbon footprint

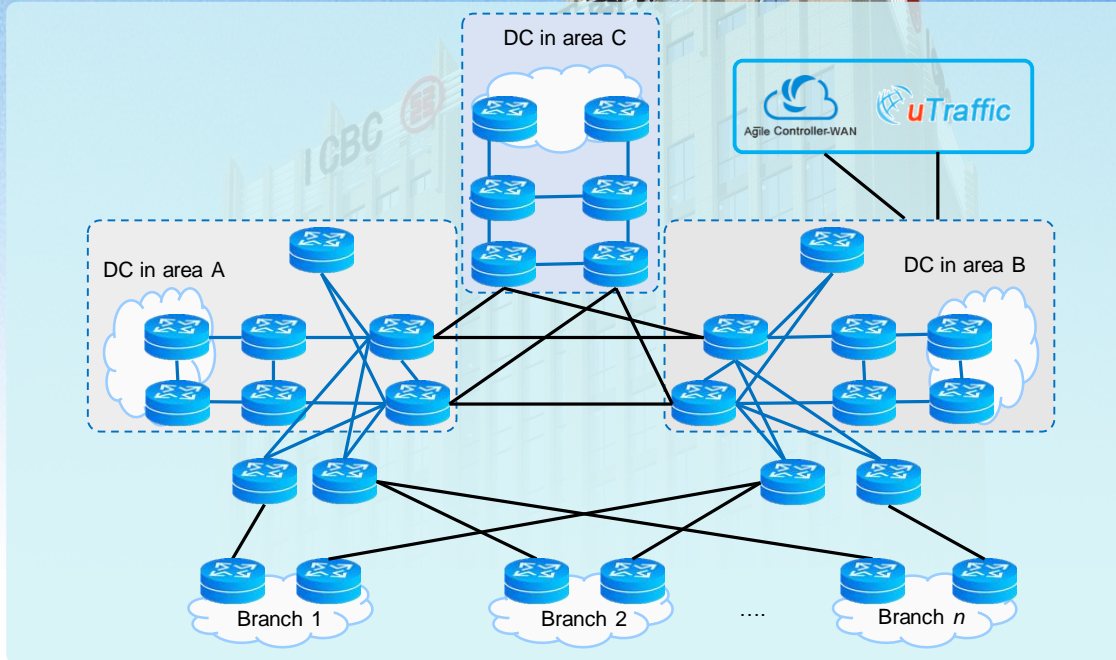

Requirements

- ◆ ICBC is one of the four largest banks in China. It aims to build a future-oriented, next-generation WAN SDN network to improve the efficiency of its network deployment and O&M.
- ◆ Existing network technologies are outdated and some routing protocols are non-standard. Therefore, interconnection and communication between devices from multiple vendors are urgently needed.
- ◆ Since a live network is incapable of using VPNs, and network resources cannot be shared between services, a network is needed to transmit multiple services.
- ◆ Low bandwidth utilization and complex rollout of new services require automated network deployment and traffic optimization.

Solution

- ◆ Open standard routing protocols enhance interconnection and interworking capabilities.
- ◆ Network virtualization and VPNs enable a physical network to carry multiple isolated services and ensure security.
- ◆ Evolution to SDN automates service configuration and optimizes intelligent traffic.

Benefits

- ◆ The reliability and scalability of the network architecture are greatly improved. With multiple planes and virtualization, service bearer becomes more secure and reliable.
- ◆ Automated configuration and service provisioning accelerate rollouts of new services.
- ◆ Visualized O&M improves O&M efficiency and locates faults within minutes.
- ◆ IT resource pooling improves resource utilization and reduces costs by 70%.

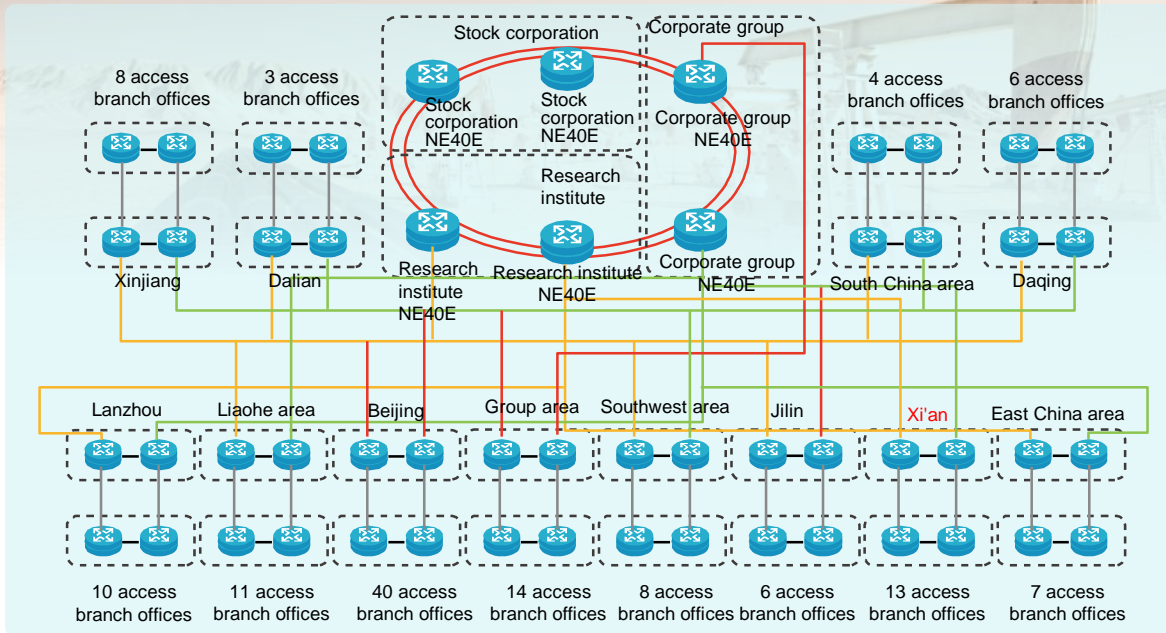

Requirements

China National Petroleum Corporation (CNPC) is **one of the largest integrated energy companies in the world**. Its WAN is an important part of information technology infrastructure construction. This WAN requires high reliability, no single point of failure, and **24/7 availability** to ensure the quality of key services such as **Enterprise Resource Planning (ERP)** and videos.

Solution

- ◆ The entire network uses a three-layer architecture consisting of more than 100 core routers (NE40Es). **All nodes and links are carefully designed**. The entire network is highly reliable and has no single point of failure.
- ◆ Hardware-based BFD is deployed on the network to ensure network convergence within 50 ms.
- ◆ HQoS **implements** differentiated service policies and scheduling. If network congestion occurs, key services are preferentially transmitted and service quality **is assured**.

Benefits

A highly secure, high-performance, **manageable WAN maintains** network interconnection between level-2 branches. Unified **service bearer improves collaboration and decision making efficiency** among branches. **CNPC's goal is to become a world-class international energy enterprise by 2020**.



Jointly presented by
Router Ethernet Marketing Support Dept. & Network Information Dept.

More <http://e.huawei.com>