

Huawei CX210 Switch Module
V100R001C10

White Paper

Issue **08**
Date **2017-03-27**

Copyright © Huawei Technologies Co., Ltd. 2017. All rights reserved.

No part of this document may be reproduced or transmitted in any form or by any means without prior written consent of Huawei Technologies Co., Ltd.

Trademarks and Permissions



HUAWEI and other Huawei trademarks are trademarks of Huawei Technologies Co., Ltd.

All other trademarks and trade names mentioned in this document are the property of their respective holders.

Notice

The purchased products, services and features are stipulated by the contract made between Huawei and the customer. All or part of the products, services and features described in this document may not be within the purchase scope or the usage scope. Unless otherwise specified in the contract, all statements, information, and recommendations in this document are provided "AS IS" without warranties, guarantees or representations of any kind, either express or implied.

The information in this document is subject to change without notice. Every effort has been made in the preparation of this document to ensure accuracy of the contents, but all statements, information, and recommendations in this document do not constitute a warranty of any kind, express or implied.

Huawei Technologies Co., Ltd.

Address: Huawei Industrial Base
Bantian, Longgang
Shenzhen 518129
People's Republic of China

Website: <http://e.huawei.com>

About This Document

Purpose

The white paper for E9000 CX210 FC switch module describes functions, advantages, appearance, specifications, networking, standards and certifications, and regulatory compliance of Huawei CX210. You can learn about the CX210 by reading this document.





Intended Audience

This document is intended for:

- Huawei presales engineers
- Channel partner presales engineers
- Enterprise presales engineers

Symbol Conventions

The symbols that may be found in this document are defined as follows:

Symbol	Description
 DANGER	DANGER indicates a hazard with a high level or medium level of risk which, if not avoided, could result in death or serious injury.
 WARNING	WARNING indicates a hazard with a low level of risk which, if not avoided, could result in minor or moderate injury.
 CAUTION	CAUTION indicates a potentially hazardous situation that, if not avoided, could result in equipment damage, data loss, performance deterioration, or unanticipated results.
 TIP	TIP indicates a tip that may help you solve a problem or save time.
 NOTE	NOTE provides additional information to emphasize or supplement important points of the main text.

Change History

Issue 08 (2017-03-27)

This issue is the eighth official release.

Mode	Change Description
Added	Added product model descriptions to 1.3 Appearance .

Issue 07 (2017-02-17)

This issue is the seventh official release.

Mode	Change Description
Modified	Changed the altitude in 1.8 Technical Specifications .

Issue 06 (2016-11-22)

This issue is the sixth official release.

Mode	Change Description
Added	Added the description about the working temperature's compliance with the ASHRAE Class A3 standard in 1.8 Technical Specifications .

Issue 05 (2016-05-12)

This issue is the fifth official release.

Mode	Change Description
Added	In 1.7 Software and Hardware Compatibility , the following note is added: FC ports of the CX210 support only single-mode and multi-mode Brocade swappable optical modules.
	Added the long-term storage temperature and humidity to 1.8 Technical Specifications .
	Updated the appearance figure and description in 1.3 Appearance .
	Updated the supported optical and electrical modules and cables in 1.7 Software and Hardware Compatibility .
Modified	The reference to the throughput is added to 1.8 Technical Specifications .

Issue 04 (2015-07-17)

This issue is the fourth official release.

Mode	Change Description
Modified	The reference to the throughput is added to 1.8 Technical Specifications .

Issue 03 (2015-03-20)

This issue is the third official release.

Issue 02 (2015-02-16)

This issue is the second official release.

Mode	Change Description
Modified	The reference to the Networking Assistant is added to 1.6 Internal Chassis Networking .

Issue 01 (2014-09-15)

This issue is the first official release.

Contents

About This Document.....	ii
1 Overview.....	1
1.1 Function.....	2
1.2 Advantages.....	3
1.3 Appearance.....	4
1.4 Ports.....	7
1.5 Indicators.....	9
1.6 Internal Chassis Networking.....	11
1.7 Software and Hardware Compatibility.....	13
1.8 Technical Specifications.....	14
2 Standards and Certifications.....	16
2.1 Standards Compliance.....	17
2.2 Certifications.....	19

1 Overview

About This Chapter

1.1 Function

This topic describes the main functions, supported protocols, and port types of the CX210 GE switch module.

1.2 Advantages

The CX210 delivers high performance and various data center features, and supports on-demand configuration and flexible deployment. In addition, the CX210 switch module can be easily deployed and maintained.

1.3 Appearance

This topic describes the CX210 in terms of its appearance, panel, and installation positions in the chassis.

1.4 Ports

This topic describes the features, numbering rules, names, types, and quantities of the CX210 ports.

1.5 Indicators

This topic describes the names, meanings, colors and status of the indicators on the CX210.

1.6 Internal Chassis Networking

This topic describes connection relationships between the CX210 and mezz modules on compute nodes.

1.7 Software and Hardware Compatibility

This topic describes mezz modules that can work with the CX210 and pluggable modules and cables supported by ports on the CX210 panel.

1.8 Technical Specifications

This topic describes the physical, environmental, power, and network switching specifications of the CX210.

1.1 Function

This topic describes the main functions, supported protocols, and port types of the CX210 GE switch module.

The CX210 FC switch module (CX210 for short) is a storage switching unit that provides storage data switching functionality for service slots in the system and centrally provides service, and management interfaces for external devices.

The CX210 is installed in the rear slot of the E9000 chassis and connected to compute nodes, and management modules through the E9000 midplane. The CX210 performs switching of storage data packets and the management system to provide high-speed data transmission.

Table 1-1 describes the functions of the CX210.

Table 1-1 FC switching plane function description

Function		Description
Fibre Channel (FC) switching	FC optical port	Supports 4G/8G FC autonegotiation, full duplex.
	Switching	<ul style="list-style-type: none"> ● Supports the FC switching mode (Native) and access gateway mode (that is, NPV mode). NPV is short for N-Port virtualization. ● Supports free mapping to the internal fibre channel (FC) ports and external FC ports in NPV mode. ● Supports network connection between E_Ports and Brocade FC switches in FC mode. A license is required for the function.
	NPIV	Supports N_Port ID virtualization (NPIV). A physical port supports access of multiple N_Port_IDs.
FC switching	Link aggregation	<p>Supports FC port multi-link aggregation to expand the port bandwidth and provide redundancy.</p> <ul style="list-style-type: none"> ● Supports connection only to Brocade FC switches. ● Requires a license.
Configuration and maintenance	Configuration and management modes	<ul style="list-style-type: none"> ● Supports configurations using command lines. ● Supports the HTTPS-based Webtool (graphical user interface). ● Simple Network Management Protocol version 1/3 (SNMPv1/v3). ● Supports the FC Fabric Element management information base (MIB).

Function		Description
	Connection mode	<ul style="list-style-type: none"> ● Ethernet connection (over SSH, SNMP, or the Web). ● Serial over LAN (SOL) connection.
	Version upgrade	<p>Supports online upgrades for software. Services are not interrupted during an upgrade. The upgrade takes effect after the restart.</p> <p>NOTE To ensure secure service application, periodically upgrade the switch module software version.</p>
Network security	System security	<ul style="list-style-type: none"> ● Hierarchical rights management based on user levels, preventing unauthorized users from accessing switch modules. ● Supports Secure Shell (SSH) and Secure Sockets Layer (SSL). ● Supports Hypertext Transfer Protocol Secure (HTTPS). ● Supports SNMPv1/v3. ● Supports Remote Authentication Dial In User Service (RADIUS) for user logins. ● Supports SSH login using the username and password or public and private keys.

1.2 Advantages

The CX210 delivers high performance and various data center features, and supports on-demand configuration and flexible deployment. In addition, the CX210 switch module can be easily deployed and maintained.

High Performance

The CX210 FC switching plane provides eight 8G FC ports for connecting to the FC SAN and provide 192 Gbit/s switching capacity (384 Gbit/s throughput).

Easy Deployment and Maintenance

The CX210 provides one FC switching plane, which is easy to deploy. The panel indicators show the link connection status and fault status. The software upgrade and configuration files are easy to import or export, which facilitates maintenance.

On-Demand Configuration and Flexible Deployment

The FC switching plane of the CX210 provides eight 8G FC ports. Four of the ports are activated by default, and the other four ports require licenses for activation, which addresses diverse user needs.

Data Center Features

- Supports seamless intercommunication with the FC infrastructure, protecting investments on the FC SAN.
- Supports server virtualization and NPIV access to improve the data center interface bandwidth usage.

1.3 Appearance

This topic describes the CX210 in terms of its appearance, panel, and installation positions in the chassis.

Appearance

Figure 1-1 shows the CX210.

Figure 1-1 Appearance



Installation Positions

The CX210 can be installed in the four slots at the rear of the E9000 chassis. The four slots are 1E, 2X, 3X, and 4E, as shown in **Figure 1-2**.

Figure 1-2 Installation positions and slot numbers

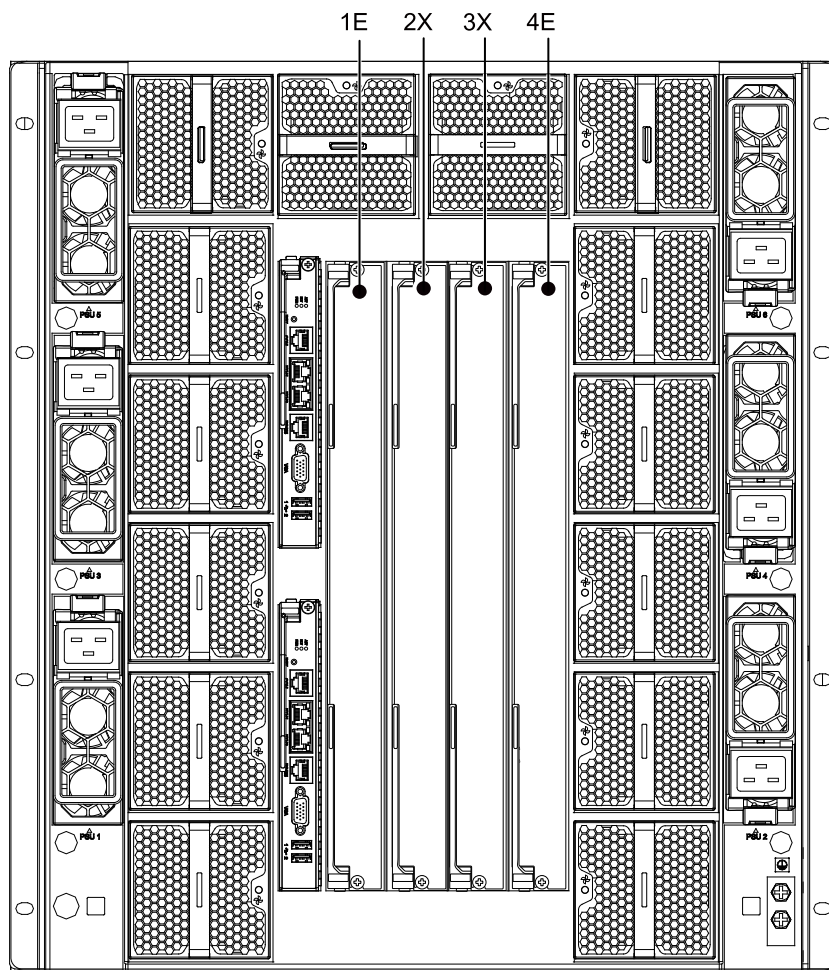

Panel

Figure 1-3 shows the CX210 panel.

Figure 1-3 Panel

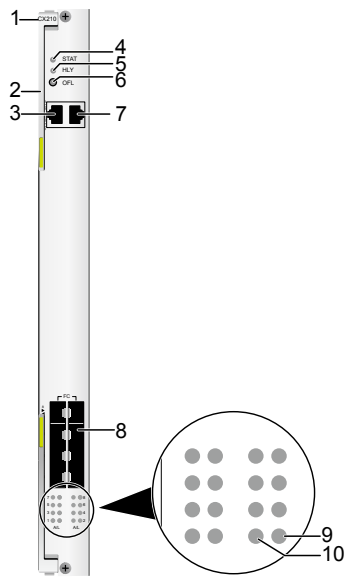

1	Product model	2	Customization label (with an ESN label)
3	BMC serial port	4	Power indicator
5	Health status indicator	6	Offline button/indicator
7	SYS serial port	8	8G FC optical port
9	Connection status indicator of the 8G FC 10 optical port		Diagnosis status indicator of the 8G FC optical port

NOTE

The numbers on the left side are port serial numbers. The arrow direction of a triangle indicates the direction of a port.

ESNs

An Equipment Serial Number (ESN) is a string that uniquely identifies a server. An ESN is required when you apply for technical support from Huawei.

Figure 1-4 shows the ESN format.

Figure 1-4 ESN example

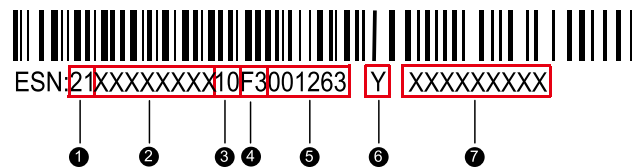

No.	Description
1	Indicates the ESN ID (two digits).
2	Indicates the item identification code (eight characters).
3	Indicates the vendor code (two characters).
4	Indicates the year and month (two characters). The first character indicates the year. The digits 1 to 9 indicate 2001 to 2009, and the letters A to Z indicate 2010 to 2035. The second character indicates the month. The digits 1 to 9 indicate January to September, and the letters A to C indicate October to December.
5	Indicates the sequence number (six digits).
6	Indicates RoHS compliance (one character).
7	Indicates the internal model number of the board.

1.4 Ports

This topic describes the features, numbering rules, names, types, and quantities of the CX210 ports.

The CX210 provides ports for users to operate and configure the CX220 and receive and send service data.

The FC optical ports on the CX210 panel are numbered from 1 to 8. See [Figure 1-5](#) and [Table 1-2](#). For details about internal port numbers, see [Table 1-4](#).

Figure 1-5 Port numbering rules

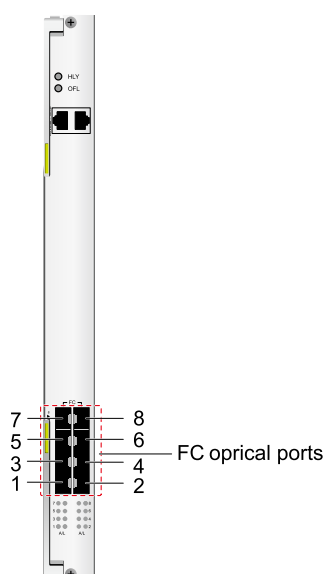

Table 1-2 describes the external ports on the CX210.

Table 1-2 External ports

Name	Type	Quantity	Subcard Number	Port Number	Description
Serial port	RJ45	2	-	-	<p>The serial ports include the baseboard management controller (BMC) serial port and the SYS serial port. The ports comply with RS232. No indicator is available.</p> <ul style="list-style-type: none">● BMC serial port: The port is used to log in to the BMC command-line interface (CLI).● SYS serial port: This port is used for managing, maintaining, and commissioning the FC switching plane. <p>The BMC serial port support the baud rate of 115,200 bit/s.</p> <p>The serial port of the FC switching plane supports the baud rate of 9,600 bit/s.</p>
8G FC port	SFP+	8	-	-	<p>The FC switching plane provides eight 8G FC ports for connecting to the FC storage network. Ports 1 to 4 are activated by default, and ports 5 to 8 require licenses for activation.</p> <p>Each port has two indicators. The orange one is a diagnosis status indicator, and the green one is a connection status indicator.</p>

Table 1-3 Internal ports

Name	Type	Quantity	Subcard Number	Port Number	Description	Example
GE port	-	32	1 to 16	The value is 1 to 2.	This port is connected to half-width front slots 01 to 16. Each half-width slot maps to two port numbers.	If the CX210 is in slot 2X, the ports connected to the compute node in slot 1 are numbered GE 2/1/1 and GE 2/1/2.
GE port	-	2	19	The value is 1 to 2.	The two GE ports connect to and communicate with two MM910s. The two ports can communicate with the MM910s only when the switch module is in slot 2X or 3X.	If the CX210 is in slot 2X, the ports are numbered GE 2/19/1 and GE 2/19/2.

Table 1-4 describes the internal ports on the CX210 FC switching plane.

Table 1-4 FC switching plane internal ports

Name	Type	Quantity	Description
FC port	0	1	The port is connected to half-width slot 16.
FC port	9 to 23	15	The ports are connected to half-width front slots 01 to 15.

 **NOTE**

The internal FC interface rate must be set to 8 Gbit/s.

1.5 Indicators

This topic describes the names, meanings, colors and status of the indicators on the CX210.

By observing the indicators, you can determine the current operating status of the CX210.

Table 1-5 describes the indicators on the CX210 panel.

Table 1-5 Indicator description

Label	Meaning	Color	Description
STAT	Power indicator	Green	<ul style="list-style-type: none"> ● Off: The CX210 is not powered on. ● Blinking green: The CX210 is being powered on. ● Steady green: The CX210 is operating properly.
HLY	Health indicator	Red and green	<ul style="list-style-type: none"> ● Off: The CX210 is not powered on. ● Steady green: The CX210 is operating properly or has minor alarms. ● Blinking red (1 Hz): A major alarm is generated. ● Blinking red (at 5 Hz): A critical alarm is generated for the CX210, or the CX210 is not securely installed.
OFL	Offline button/ indicator (reserved)	N/A	None.
A	Diagnosis status indicator for the 8G FC optical port	Orange	<ul style="list-style-type: none"> ● Off: No optical module is installed, or an exception occurs when the port is receiving optical signals. (The L indicator is also off.) ● Steady orange: The port is not synchronized, and a connection exception occurs. ● Blinking orange (once/2 seconds): The port is disabled. ● Blinking orange (twice/second): The port is faulty.

Label	Meaning	Color	Description
L	Connection status indicator for the 8G FC optical port	Green	<ul style="list-style-type: none"> ● Off: No optical module is installed, or an exception occurs when the port is receiving optical signals. (The A indicator is also off.) ● Steady green: The port is normal, and the link is connected. ● Blinking green (blinking every two seconds): The port is normal but isolated. No link is set up. ● Blinking green (blinking twice per second): The port is in the diagnosis state. ● Blinking green (blinking four times per second): The link is properly set up and the port is transmitting data.

1.6 Internal Chassis Networking

This topic describes connection relationships between the CX210 and mezz modules on compute nodes.

For details about the networking of the CX210 and Mezz cards on compute nodes, see [E9000 Blade Server Mezz Module-Switch Module Interface Mapping Tool](#).

Figure 1-6 shows the internal chassis networking for the CX210 and compute nodes. Ports on compute nodes for connecting to the CX210 are provided by two mezz modules as follows:

- Mezz 1 connects to the FC switching planes of the CX210s in slots **2X** and **3X**.
- Mezz 2 connects to the FC switching planes of the CX210s in slots **1E** and **4E**.

Figure 1-6 Mapping between the CX210 and mezz modules on compute nodes

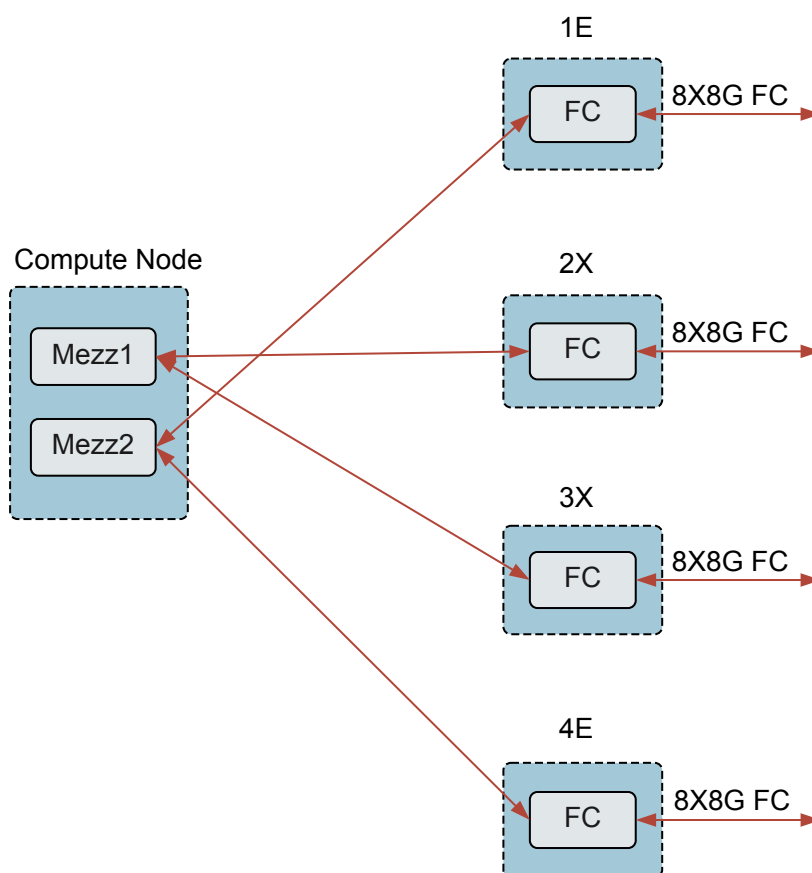

NOTE

If a compute uses the ports provided by four mezz modules to connect to the CX210, slots Mezz1 and Mezz3 connect to switch module slots 2X and 3X respectively, and slots Mezz2 and Mezz4 connect to switch module slots 1E and 4E respectively.

The following describes the mapping between the CX210s and mezz modules. For example, the CX210s are installed in slots 2X and 3X and connect to Mezz 1.

Port Mapping Between a Switch Module and a Mezz Module

Mapping between the CX210 and ports on the MZ220

The two 16G FC ports (ports 1 and 2) on the MZ220 map to the FC switching planes of the CX210s in slots 2X and 3X respectively, as shown in [Figure 1-7](#).

NOTE

The two 16G FC ports on the MZ220 are switched to 8G FC ports to connect to the CX210 FC switching plane.

Figure 1-7 Mapping between the CX210 and ports on the MZ220

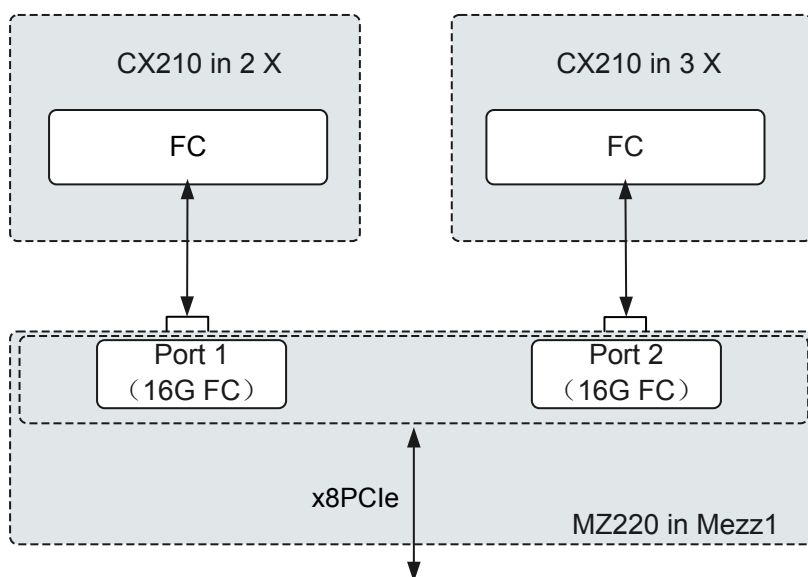

1.7 Software and Hardware Compatibility

This topic describes mezz modules that can work with the CX210 and pluggable modules and cables supported by ports on the CX210 panel.

For details about the software and hardware that are compatible with the CX210, see [Huawei Server Compatibility Checker](#).

Supported Mezz Modules

The CX210 connects to mezz modules of compute nodes. [Table 1-6](#) describes models and specifications of the supported mezz modules.

Table 1-6 Supported mezz modules

Model	Specifications
MZ220	FC mezzanine card with two 16G FC ports

Supported Pluggable Modules and Cables

Table 1-7 Supported pluggable modules and cables

Module/Cable	Description
SFP+ multi-mode optical module (8G)(Only Brocade SFP+ optical modules are supported.)	Supports FC-PI-4.
SFP+ single-mode optical module (8G)(Only Brocade SFP+ optical modules are supported.)	Supports FC-PI-4.
Multi-mode fiber (MMF)	Supports the MMF of 850 nm OM1/OM2/OM3.
Single-mode fiber (SMF)	Supports the 1310 SMF.
Console cable	Supports the RJ45 port and serves as the connection cable for RS232 serial ports.

The CX210 supports:

- SFP+ optical ports
- Single-mode and multi-mode 8G SFP+ optical modules
- 8 Gbit/s and 16Gbit/s
- various optical cables

You can choose the components based on site requirements.

 **NOTE**

The CX210 supports only pluggable Brocade multi-mode and single-mode optical modules.

1.8 Technical Specifications

This topic describes the physical, environmental, power, and network switching specifications of the CX210.

Table 1-8 describes the technical specifications of the CX210, and **Table 1-9** describes the network switching specifications of the CX210.

For details about the FC switching plane switching performance, see the [MX210&MX220_Fabric_OS_Administrator_Guide](#).

Table 1-8 Technical specifications

Category	Item	Specifications
Physical specifications	Dimensions (H x W x D)	388.55 mm x 35.06 mm x 272.15 mm (15.30 in. x 1.38 in. x 10.71 in.)

Category	Item	Specifications
	Color	Silver white
	Weight	2.3 kg
Environmental specifications	Temperature	<ul style="list-style-type: none"> ● Operating temperature: 5°C to 40°C (41°F to 104°F) (ASHRAE Class A3 compliant) ● Storage temperature: -40°C to +65°C (-40°F to +149°F) ● Long-term storage temperature: 21°C to 27°C (69.8°F to 80.6°F)
	Temperature change rate	15°C/h (27°F/h)
	Humidity	<ul style="list-style-type: none"> ● Operating humidity: 5% RH to 85% RH (non-condensing) ● Storage humidity: 5% RH to 95% RH (non-condensing) ● Long-term storage humidity: 30% RH to 69% RH (non-condensing)
	Altitude	<p>At an altitude of 900 m (2952.72 ft), the highest operating temperature is 40°C (104°F).</p> <p>When the device is used at an altitude of 900 m to 5000 m, the highest operating temperature decreases by 1°C (1.8°F) as the altitude increases by 300 m (984.24 ft).</p>
Input power supply	Rated input voltage	12 V DC
Power consumption	Maximum power consumption	50 W

Table 1-9 Network switching specifications

Item	Description	Specifications
Quantity of ports on the panel	10	<ul style="list-style-type: none"> ● One BMC serial port and one SYS serial port ● Eight 8 Gbit/s FC optical ports
Port rate	FC switching plane: 4G FC and 8G FC optical ports	Full duplex mode
Switching capability (throughput)	FC switching plane: 384 Gbit/s	-

2 Standards and Certifications

About This Chapter

[2.1 Standards Compliance](#)

This topic describes the international and industrial standards and communication protocols that the CX210 complies with.

[2.2 Certifications](#)

This topic describes the certifications that the E9000 has passed.

2.1 Standards Compliance

This topic describes the international and industrial standards and communication protocols that the CX210 complies with.

International Standards

[Table 2-1](#) lists the international standards.

Table 2-1 Standards and protocol compliance

Standard	Protocol
FC-DA	FC Device Attach
FC-FS-2	FC Framing and Signaling
FC-GS-5	FC Generic Service
FC-LS	FC Link ServiceFC Link Service
FC-MI-2	FC Methodologies for Interconnects
FC-PI-4	FIBRE CHANNEL. Physical Interface-4 8G FC Interface
FC-SW-4	FC Switch Fabric
FC-VI	FC Virtual Interface Architecture Mapping
FCP-3	Fibre Channel Protocol for SCSI
RFC2837	Fabric Element MIB Specification
IEEE 1149.1-2001	IEEE Standard Test Acces Port and Boundary-Scan Architecture
SFF-8431	Enhanced Small Form Factor Pluggable Module SFP+
SFF-8472	Diagnostic Monitoring Interface for Optical Transceivers

Industrial Standards

[Table 2-2](#) lists the industrial standards.

Table 2-2 Industrial standards

Organization	Standard
ECMA TR/70	Environment protection
EN60950	Safety (Europe)
GR-929	Reliability
IEC 863	Reliability, maintainability, and availability compliance standard

Organization	Standard
IEC60297	Chassis compliance
IEC60950	Safety
IEC60825-1/2/6	Safety
IEC60215	Safety
IEC61000	EMC standard
Telcordia SR-332	Reliability
UL60950	Safety (North America)

Communication Protocols

Table 2-3 lists the communication protocols.

Table 2-3 Communication protocols

Protocol	Description
ARP	Address Resolution Protocol
DHCP	Dynamic Host Configuration Protocol
FTP	File Transfer Protocol (By default, it is disabled. You can run a command to enable it.)
SFTP	Secure File Transfer Protocol
HTTPS	Hypertext Transfer Protocol Security
ICMP	Internet Control Message Protocol
IP	Internet Protocol
IPMI	Intelligent Platform Management Interface
IPv4/IPv6	IPv4/IPv6 Internet Protocol
NTP	Network Time Protocol
RADIUS	Remote Authentication Dial In User Service
SNMP	Simple Network Management Protocol (V1/V3)
SSH	Secure Shell
SSL	Secure Socket Layer
TCP	Transmission Control Protocol
TELNET	Remote terminal protocol (By default, it is disabled. You can run a command to enable it.)

Protocol	Description
TFTP	Trivial File Transfer Protocol (By default, it is disabled. You can run a command to enable it.)
UDP	User Datagram Protocol

2.2 Certifications

This topic describes the certifications that the E9000 has passed.

[Table 2-4](#) lists the certifications.

Table 2-4 Certifications

Country /Region	Certification	Standard
Europe	WEEE	2002/96/EC, 2012/19/EU
Europe	RoHS	2002/95/EC, 2011/65/EU, EN 50581: 2012
Europe	REACH	EC NO. 1907/2006
Europe	CE	Safety: EN 60950-1: 2006+A11: 2009+A1: 2010+A12: 2011 EMC: <ul style="list-style-type: none">● EN 55022: 2010● CISPR 22: 2008● EN 55024: 2010● CISPR 24: 2010● ETSI EN 300 386 V1.6.1: 2012● ETSI ES 201 468 V1.3.1: 2005
China	RoHS	SJ/T-11363-20006 SJ/T-11364-20006 GB/T 26572-2011
China	China Environmental Labeling	GB/T24024: 2001 idt ISO14024: 1999 HJ 2507-2011
Australia	C-tick	AS/NZS CISPR22: 2009
America	UL	UL 60950-1
America	FCC	FCC Part 15 (Class A)

Country /Region	Certification	Standard
America	NTRL-UL	UL 60950-1, 2nd Edition, 2011-12-19 (Information Technology Equipment - Safety - Part 1: General Requirements) CSA C22.2 No.60950-1-07, 2nd Edition, 2011-12 (Information Technology Equipment-Safety-Part 1: General Requirements)
Canada	IC	ICES-003 Class A
Nigeria	SONCAP	IEC 60950-1: 2005 (2nd Edition) + A1: 2009 EN 60950-1: 2006+A11: 2009+A1: 2010 + A12: 2011
Kingdom of Saudi Arabia (KSA)	SASO	IEC 60950-1: 2005 (2nd Edition) + A1: 2009 EN 60950-1: 2006+A11: 2009+A1: 2010 + A12: 2011
Global	CB	IEC 60950-1
Japan	VCCI	VCCI V-4: 2012