



Huawei CX915 Switch Module
V100R001C10

White Paper

Issue **07**
Date **2017-03-27**

Copyright © Huawei Technologies Co., Ltd. 2017. All rights reserved.

No part of this document may be reproduced or transmitted in any form or by any means without prior written consent of Huawei Technologies Co., Ltd.

Trademarks and Permissions



HUAWEI and other Huawei trademarks are trademarks of Huawei Technologies Co., Ltd.

All other trademarks and trade names mentioned in this document are the property of their respective holders.

Notice

The purchased products, services and features are stipulated by the contract made between Huawei and the customer. All or part of the products, services and features described in this document may not be within the purchase scope or the usage scope. Unless otherwise specified in the contract, all statements, information, and recommendations in this document are provided "AS IS" without warranties, guarantees or representations of any kind, either express or implied.

The information in this document is subject to change without notice. Every effort has been made in the preparation of this document to ensure accuracy of the contents, but all statements, information, and recommendations in this document do not constitute a warranty of any kind, express or implied.

Huawei Technologies Co., Ltd.

Address: Huawei Industrial Base
Bantian, Longgang
Shenzhen 518129
People's Republic of China

Website: <http://e.huawei.com>

About This Document

Purpose

The white paper for E9000 CX915 multi-plane switch module describes functions, advantages, appearance, specifications, networking, standards and certifications, and regulatory compliance of Huawei CX915. You can learn about the CX915 by reading this document.





Intended Audience

This document is intended for:

- Huawei presales engineers
- Channel partner presales engineers
- Enterprise presales engineers

Symbol Conventions

The symbols that may be found in this document are defined as follows:

Symbol	Description
 DANGER	DANGER indicates a hazard with a high level or medium level of risk which, if not avoided, could result in death or serious injury.
 WARNING	WARNING indicates a hazard with a low level of risk which, if not avoided, could result in minor or moderate injury.
 CAUTION	CAUTION indicates a potentially hazardous situation that, if not avoided, could result in equipment damage, data loss, performance deterioration, or unanticipated results.
 TIP	TIP indicates a tip that may help you solve a problem or save time.

Symbol	Description
 NOTE	NOTE provides additional information to emphasize or supplement important points of the main text.

Change History

Issue 07 (2017-03-27)

This issue is the seventh official release.

Mode	Change Description
Added	Added product model descriptions to 1.3 Appearance .

Issue 06 (2017-02-17)

This issue is the sixth official release.

Mode	Change Description
Modified	Changed the altitude in 1.8 Technical Specifications .

Issue 05 (2016-11-22)

This issue is the fifth official release.

Mode	Change Description
Added	Added the description about the working temperature's compliance with the ASHRAE Class A3 standard in 1.8 Technical Specifications .

Issue 04 (2016-05-12)

This issue is the fourth official release.

Mode	Change Description
Added	Added the long-term storage temperature and humidity to 1.8 Technical Specifications .
Deleted	Deleted some international standards in 2.1 Standards Compliance .

Mode	Change Description
	Deleted the Transparent Interconnection of Lots of Links (TRILL) protocol in 2.1 Standards Compliance .
	In 1.6 Internal Chassis Networking , the connection relationships with the MZ110 and MZ111 are deleted.

Issue 03 (2015-07-17)

This issue is the third official release.

Mode	Change Description
Modified	The reference to the throughput is added to 1.8 Technical Specifications .

Issue 02 (2015-02-16)

This issue is the second official release.

Mode	Change Description
Modified	The reference to the Networking Assistant is added to 1.6 Internal Chassis Networking .

Issue 01 (2014-09-15)

This issue is the first official release.

Contents

About This Document.....	ii
1 Overview.....	1
1.1 Function.....	2
1.2 Advantages.....	9
1.3 Appearance.....	10
1.4 Ports.....	13
1.5 Indicators.....	17
1.6 Internal Chassis Networking.....	19
1.7 Software and Hardware Compatibility.....	21
1.8 Technical Specifications.....	23
2 Standards and Certifications.....	26
2.1 Standards Compliance.....	27
2.2 Certifications.....	29

1 Overview

About This Chapter

1.1 Function

This topic describes the main functions, supported protocols, and port types of the CX915 GE switch module.

1.2 Advantages

The CX915 provides high performance, high-density ports, and high specifications, and supports large data center networks, high-performance stacking, and various data center features. In addition, the CX915 switch module is easy to deploy and maintain.

1.3 Appearance

This topic describes the CX915 in terms of its appearance, panel, and installation positions in the chassis.

1.4 Ports

This topic describes the features, numbering rules, names, types, and quantities of the CX915 ports.

1.5 Indicators

This topic describes the names, meanings, colors and status of the indicators on the CX915.

1.6 Internal Chassis Networking

This topic describes connection relationships between the CX915 and mezz modules on compute nodes.

1.7 Software and Hardware Compatibility

This topic describes mezz modules that can work with the CX915 and pluggable modules and cables supported by ports on the CX915 panel.

1.8 Technical Specifications

This topic describes the physical, environmental, power, and network switching specifications of the CX915.

1.1 Function

This topic describes the main functions, supported protocols, and port types of the CX915 GE switch module.

The CX915 multi-plane switch module (CX915 for short) is a switch control unit that provides data switching functionality for service slots in the system and centrally provides service, and management interfaces for external devices. The CX915 provides two independent planes, including the GE switching plane, and FC switching plane. The two planes are physically isolated.

The CX915 is installed in the rear slot of the E9000 chassis and connected to compute nodes, store nodes, and management modules through the E9000 midplane. The CX915 performs switching of internal data packets and control management packets to provide high-speed data transmission.

Table 1-1 describes functions of the GE switching plane of the CX915. **Table 1-2** describes functions of the FC switching plane of the CX915.

Table 1-1 GE switching plane function description

Function		Description
Ethernet features	Ethernet	<ul style="list-style-type: none"> ● Operating modes of full-duplex and auto-negotiation ● Ethernet ports support: GE, 10GE. <p>NOTE</p> <ul style="list-style-type: none"> ● 10GE optical ports support passive direct attached cables (DACs). ● 10GE optical ports support GE and 10GE multi-mode and single-mode optical modules. <ul style="list-style-type: none"> ● Port traffic control <p>NOTE</p> <p>10GE optical interfaces do not support flow control.</p> <ul style="list-style-type: none"> ● Jumbo frames ● Link aggregation ● Load balancing among links within a trunk ● Interface isolation and forwarding restrictions ● Broadcast storm suppression
	Virtual Local Area Network (VLAN)	<ul style="list-style-type: none"> ● Access modes of access, trunk, and hybrid ● VLAN assignment: port-based, MAC address-based, IP subnet-based VLAN assignment ● VLAN aggregation ● Multiplex VLAN (MUX VLAN) ● Transparent Transmission of Protocol Packets in a VLAN

Function		Description
	802.1Q in 802.1Q (QinQ)	<ul style="list-style-type: none"> ● Basic QinQ ● Selective QinQ
	VLAN Mapping	<ul style="list-style-type: none"> ● 1 to 1 VLAN mapping. ● 2 to 1 VLAN mapping. ● 2 to 2 VLAN mapping.
	Media Access Control (MAC)	<ul style="list-style-type: none"> ● Secure MAC addresses ● Automatic learning and aging of MAC addresses ● Static, dynamic, and blackhole MAC address entries ● Packet filtering based on source MAC addresses ● Interface-based MAC learning limits
	Link Layer Discovery Protocol (LLDP)	Support for LLDP
-	Virtual Cable Test (VCT)	Support for VCT
Ethernet loop protection	Multiple Spanning Tree Protocol (MSTP)	<ul style="list-style-type: none"> ● Spanning Tree Protocol (STP) ● Rapid Spanning Tree Protocol (RSTP) ● MSTP ● Bridge protocol data unit (BPDU) protection, root protection, and loop protection ● Partitioned STP and Layer 2 protocol transparent transmission
IP features	Address Resolution Protocol (ARP)	<ul style="list-style-type: none"> ● Static and dynamic ARP entries ● ARP in a VLAN ● Aging of ARP entries ● ARP and Reverse Address Resolution Protocol (RARP) ● ARP proxy ● Auto-detection
	IPv6	<ul style="list-style-type: none"> ● IPv4/IPv6 dual-stack ● Neighbor Discovery (ND) ● IPv6 over IPv4 Manual Tunnel ● IPv6 over IPv4 Generic Routing Encapsulation (GRE) Tunnel ● 6to4 Tunnel

Function		Description
	Dynamic Host Configuration Protocol (DHCP)	<ul style="list-style-type: none"> ● DHCP server ● DHCP snooping ● DHCP relay ● DHCPv6 Relay
IP forwarding	Unicast routing features	<ul style="list-style-type: none"> ● IPv4/IPv6 static routing ● Routing Information Protocol version 1 (RIP-1), RIP-2, and RIP next generation (RIPng) ● Open Shortest Path First (OSPF), including OSPFv2 and OSPFv3 ● Intermediate System to Intermediate System (IS-IS) ● Border Gateway Protocol 4.0 (BGP4) and Border Gateway Protocol for IPv6 (BGP4+) ● Routing protocol ● Policy-based routing ● Unicast Reverse Path Forwarding (URPF) check
	Virtual Private Network (VPN) features	<ul style="list-style-type: none"> ● Multi-VPN-Instance CE (MCE) and IPv6 MCE ● GRE Tunnel
	Multicast routing features	<ul style="list-style-type: none"> ● Internet Group Management Protocol version 1/2/3 (IGMPv1/v2/v3) ● Protocol Independent Multicast - Sparse Mode (PIM-SM) for IPv4 and IPv6 ● Protocol Independent Multicast Source-Specific Multicast (PIM-SSM) for IPv4 and IPv6 ● Multicast Listener Discovery version 1 and 2 (MLDv1 and MLDv2) ● MLD Source-Specific Multicast (SSM) Mapping ● Multiprotocol BGP (MBGP) ● Multicast Source Discovery Protocol (MSDP) ● Multicast routing policies ● Reverse Path Forwarding (RPF) ● Bidirectional PIM (IPv4) and Bidirectional PIM (IPv6)

Function		Description
Device reliability	Bidirectional Forwarding Detection (BFD)	<ul style="list-style-type: none"> ● BFD (IPv4) and BFD (IPv6) ● Association between BFD and Eth-Trunk ● Association between BFD and OSPF ● Association between BFD and OSPFv3 ● Association between BFD and IS-IS ● Association between BFD and IS-IS IPv6 ● Association between BFD and BGP ● Association between BFD and BGP4+ ● Association between BFD and PIM (IPv4) ● Association between BFD and PIM (IPv6) ● Association between BFD and static routing (IPv4) ● Association between BFD and static routing (IPv6) ● Association between BFD and Virtual Router Redundancy Protocol (VRRP) ● Association between BFD and VRRP6
	Others	<ul style="list-style-type: none"> ● Virtual Router Redundancy Protocol (VRRP) and VRRP6 ● Device Link Detection Protocol (DLDP) ● Smart Link ● Smart Channel ● Ethernet in the First Mile (EFM), defined in 802.3ah
Layer 2 multicast features	Layer 2 multicast features	<ul style="list-style-type: none"> ● IGMP snooping ● IGMP proxy ● Fast leave ● Multicast traffic control ● Multicast VLAN
Quality of Service (QoS) features	Traffic classification	<ul style="list-style-type: none"> ● Traffic classification based on combination of the L2 protocol header, IP 5-tuple, outbound interface, and 802.1p priority ● Traffic classification based on the C-VLAN and C-PRI of QinQ packets

Function		Description
	Traffic behavior	<ul style="list-style-type: none"> ● Access control after traffic classification ● Traffic policing based on traffic classifiers ● Re-marking based on the traffic classification result ● Class-based packet queuing ● Association between traffic classifiers and traffic behavior (actions)
	Queue scheduling	<ul style="list-style-type: none"> ● Priority queuing (PQ) scheduling ● Deficit round robin (DRR) scheduling ● PQ+DRR scheduling ● Weighted round robin (WRR) scheduling ● PQ+WRR scheduling
	Congestion avoidance	Weighted Random Early Detection (WRED)
	Rate limiting on outbound interfaces	Rate limiting on outbound interfaces
Virtualization	Many-to-one virtualization	<ul style="list-style-type: none"> ● Intelligent Stack (iStack) ● Stack split and merge ● Dual-active detection ● Version and configuration synchronization
Configuration and maintenance	Terminal service	<ul style="list-style-type: none"> ● Configuration using command lines ● Error messages and online help in English and Chinese ● Login through console and Telnet terminals ● Send function and data communications between terminal users
	File system	<ul style="list-style-type: none"> ● Directory and file management ● File upload and download using File Transfer Protocol (FTP), Trivial File Transfer Protocol (TFTP) and Secure File Transfer Protocol (SFTP)

Function		Description
	Debugging and maintenance	<ul style="list-style-type: none"> ● Unified management of logs, alarms, and debugging information ● Electronic labels ● User operation logs ● Detailed debugging information for network fault diagnosis ● Network test tools such as tracet and ping commands ● Port mirroring and traffic mirroring
	Version upgrade	<ul style="list-style-type: none"> ● Device software loading and in-service software loading ● In-service upgrade using the basic input/output system (BIOS) menu ● In-service patching <p>NOTE To ensure secure service application, periodically upgrade the switch module software version.</p>
Security and management	System security	<ul style="list-style-type: none"> ● Hierarchical command-line protection based on user levels, preventing unauthorized users from using commands to access switch modules ● Secure Shell (SSH) ● Remote Authentication Dial-In User Service (RADIUS) authentication over IPv4 or IPv6 for login users ● Huawei Terminal Access Controller Access Control System (HWTACACS) authentication over IPv4 or IPv6 for login users ● Access control list (ACL) filtering ● Dynamic ARP inspection (DAI) ● DHCP packet filtering (appending the Option 82 field) ● Defense against control packet attacks ● Defense against attacks of source address spoofing, LAND, SYN flood (TCP SYN), smurf, ping flood (Internet Control Message Protocol Echo), teardrop, and ping of death ● Logs about attacking MAC addresses

Function		Description
	Network management	<ul style="list-style-type: none"> ● Internet Control Message Protocol (ICMP)-based ping and tracert ● Simple Network Management Protocol version 1/2c/3 (SNMPv1/v2c/v3) ● Standard management information base (MIB) ● Remote network monitoring (RMON) ● NetStream, with output statistics packets in the V5, V8, or V9 format ● sFlow ● Network quality analysis(NQR)

Table 1-2 FC switching plane function description

Function		Description
Fibre Channel (FC) switching	FC optical port	Supports 4G/8G FC autonegotiation, full duplex, and the storage port function.
	Switching	<ul style="list-style-type: none"> ● Supports full fabric mode and transparent mode. ● Supports free mapping to the internal fibre channel (FC) ports and external FC ports in NPV mode.
	NPIV	Supports N_Port ID virtualization (NPIV). A physical port supports access of multiple N_Port_IDs.
FC switching	Load sharing	Supports load sharing.
Configuration and maintenance	Configuration and management modes	<ul style="list-style-type: none"> ● Supports configurations using command lines. ● Supports the HTTPS-based Webtool (graphical user interface). ● Simple Network Management Protocol version 1/3 (SNMPv1/v3). ● Supports the FC Fabric Element management information base (MIB).
	Connection mode	<ul style="list-style-type: none"> ● Ethernet connection (over SSH, SNMP, or the Web). ● Serial over LAN (SOL) connection.

Function		Description
	Version upgrade	Supports online upgrades for software. Services are not interrupted during an upgrade. The upgrade takes effect after the restart. NOTE To ensure secure service application, periodically upgrade the switch module software version.
Network security	System security	<ul style="list-style-type: none">● Hierarchical rights management based on user levels, preventing unauthorized users from accessing switch modules.● Supports Secure Shell (SSH) and Secure Sockets Layer (SSL).● Supports SNMPv1/v3.● Supports Remote Authentication Dial In User Service (RADIUS) for user logins.

1.2 Advantages

The CX915 provides high performance, high-density ports, and high specifications, and supports large data center networks, high-performance stacking, and various data center features. In addition, the CX915 switch module is easy to deploy and maintain.

High Performance and High-Density Ports

Underpinned by the leading hardware platform, the CX915 provides high-density ports and a line-speed forwarding capability. It supports next-generation server application of high performance and high density.

The CX915 GE switching plane provides 12 GE electrical ports and four 10GE SFP+ optical ports for uplinking to the trunk/core switches, and provides 32 GE ports for connecting to internal ports on high-performance compute nodes. The FC switching plane provides eight 8G FC ports for connecting to the FC SAN and provide 192 Gbit/s switching capacity (384 Gbit/s throughput).

The CX915 GE switch module supports low-latency forwarding, provides line-speed 172 Gbit/s switching capacity (throughput), and supports Ethernet frame forwarding.

High Specifications and Support for Large Data Center Networks

The CX915 provides the highest specifications in the industry. It supports a maximum of 32,768 MAC addresses and 12,288 forwarding information bases (FIBs) entries.

High-Performance Stacking, Easy Deployment and Maintenance

The CX915 supports stacking of four devices. It has the following advantages:

- Multiple access modes: A single stacking system can provide 6*10GE + 24*GE uplink ports (two devices are stacked).
- Easy deployment and maintenance:

- Pre-deployment and offline configuration are supported. The system can be pre-planned and pre-configured. Devices can be added as required, supporting plug-and-play.
- The slot ID of a device is the ID in a stacking system, facilitating device identification and maintenance.
- Indicators on the front panel indicate the role and status of a stacking system. The stacking system can be maintained without a terminal.
- Simple upgrade: The stacking system supports quick and automatic software upgrades, simplifying upgrade operations and reducing upgrade workload.
 - Rapid software upgrades: When two switch modules are stacked, the standby switch module is upgraded before the active switch module. This ensures that at least one switch module is operating.
 - Automatic software upgrades: When two switch modules are stacked, the software version is automatically synchronized from the active switch module to the standby one.

Various Data Center Features

- Supports seamless intercommunication with the FC infrastructure, protecting investments on the FC SAN.
- Virtual/virtual machine (VM) access
 - Supports virtualized servers to improve the data center interface bandwidth usage.
 - Supports virtual resource discovery. During migration of VMs, VM network policies can be automatically migrated using the virtual resource discovery function so that network resources can be allocated as required. Working with the large-scale layer 2 network, VMs can be freely migrated inside the whole data center.

1.3 Appearance

This topic describes the CX915 in terms of its appearance, panel, and installation positions in the chassis.

Appearance

[Figure 1-1](#) shows the CX915.

Figure 1-1 Appearance



Installation Positions

The CX915 can be installed in the four slots at the rear of the E9000 chassis. The four slots are 1E, 2X, 3X, and 4E, as shown in [Figure 1-2](#).

Figure 1-2 Installation positions and slot numbers

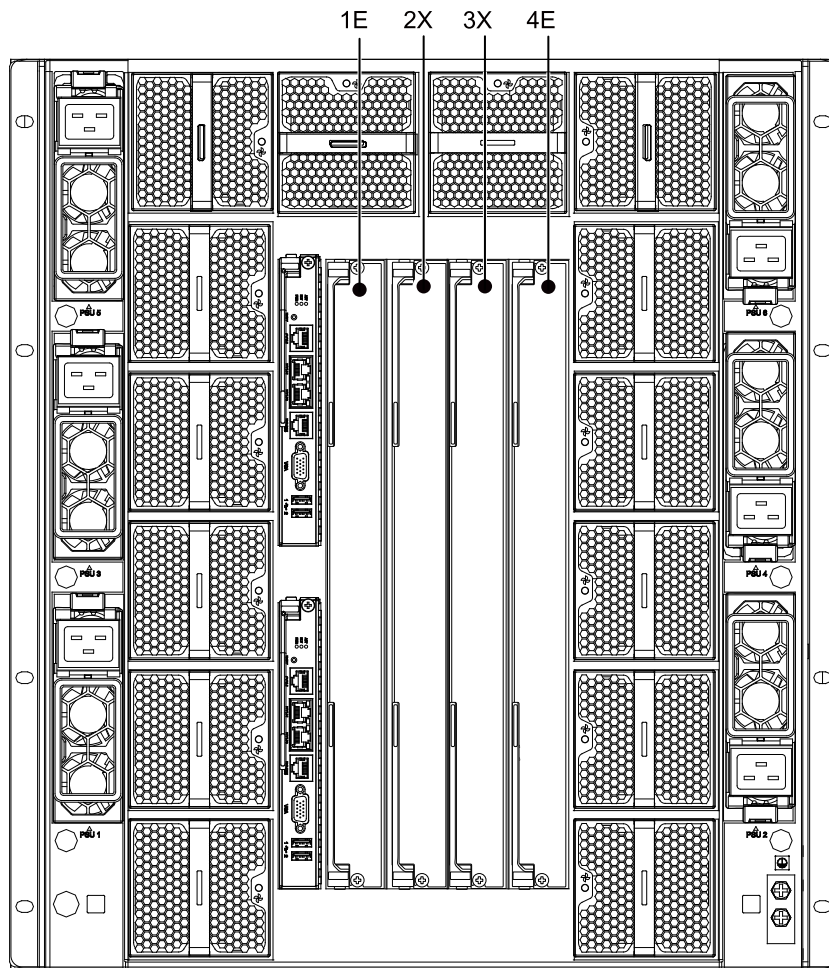

Panel

Figure 1-3 shows the CX915 panel.

Figure 1-3 Panel

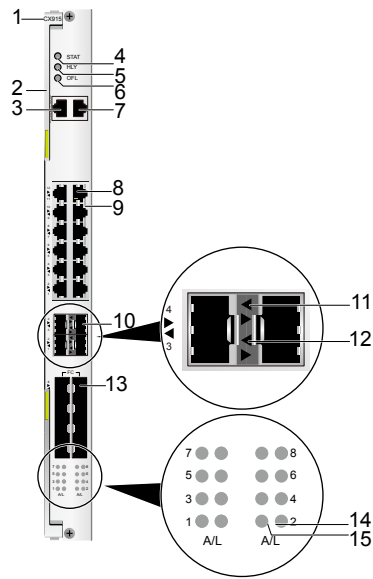

1	Product model	2	Customization label (with an ESN label)
3	BMC serial port	4	Stacking status indicator
5	Health status indicator	6	Offline button/indicator
7	SYS serial port	8	GE electrical port
9	GE electrical port indicator	10	10GE optical port
11	Connection status indicator of the 10GE	12	Data transmission status indicator of the 10GE
	optical port		optical port
13	8G FC optical port	14	Connection status indicator of the 8G
			FC optical port
15	Data transmission status indicator of the	-	-
	8G FC optical port		

NOTE

The numbers on the left side are port serial numbers. The arrow direction of a triangle indicates the direction of a port.

ESNs

An Equipment Serial Number (ESN) is a string that uniquely identifies a server. An ESN is required when you apply for technical support from Huawei.

Figure 1-4 shows the ESN format.

Figure 1-4 ESN example

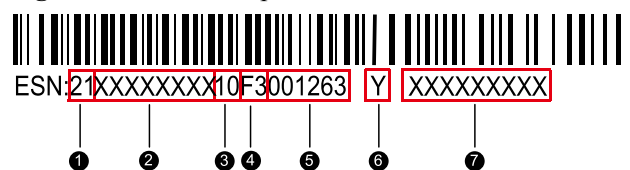

No.	Description
1	Indicates the ESN ID (two digits).
2	Indicates the item identification code (eight characters).
3	Indicates the vendor code (two characters).
4	Indicates the year and month (two characters). The first character indicates the year. The digits 1 to 9 indicate 2001 to 2009, and the letters A to Z indicate 2010 to 2035. The second character indicates the month. The digits 1 to 9 indicate January to September, and the letters A to C indicate October to December.
5	Indicates the sequence number (six digits).
6	Indicates RoHS compliance (one character).
7	Indicates the internal model number of the board.

1.4 Ports

This topic describes the features, numbering rules, names, types, and quantities of the CX915 ports.

The CX915 provides ports for users to operate and configure the CX220 and receive and send service data.

The CX915 Ethernet ports are numbered in *Slot number/Subcard number/Port number* format.

- *Slot number*: indicates the slot number of the current switch module. Its value ranges from 1 to 4, from left to right mapping to slot numbers 1E, 2X, 3X, and 4E. The slot number is equal to the stacking ID. You can set or modify the stacking ID as required.
- *Subcard number*: indicates the number of a subcard supported by service ports. The value ranges from 1 to 20.
- *Port number*: indicates the sequence number of a port on a subcard.

For details about the values, see [Figure 1-5](#), [Table 1-3](#), and [Table 1-4](#).

The FC optical ports on the CX915 panel are numbered from 1 to 8. See [Figure 1-5](#) and [Table 1-3](#). For details about internal port numbers, see [Table 1-5](#).

For example, if the CX915 is in slot 2X, the first GE electrical port on the upper right of the panel is numbered GE 2/17/12, as shown in [Figure 1-5](#).

Figure 1-5 Port numbering rules

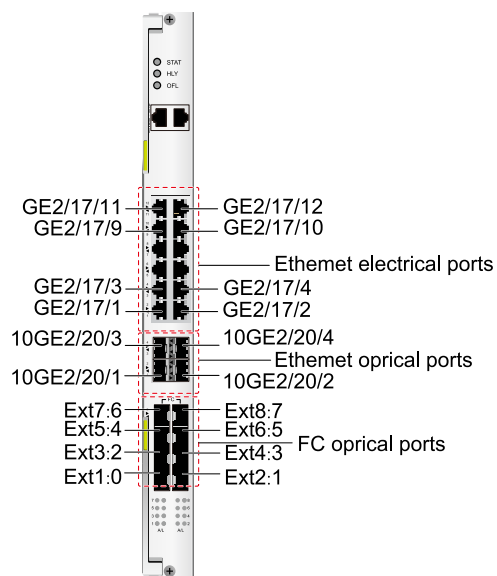

Table 1-3 describes the external ports on the CX915.

Table 1-3 External ports

Name	Type	Quantity	Subcard Number	Port Number	Description
Serial port	RJ45	2	-	-	<p>The serial ports include the baseboard management controller (BMC) serial port and the SYS serial port. The ports comply with RS232. No indicator is available.</p> <ul style="list-style-type: none"> ● BMC serial port: The port is used to log in to the BMC command-line interface (CLI). ● SYS serial port: This port is used for managing, maintaining, and commissioning the GE switching plane and FC switching plane. The SYS serial port connects to the GE switching plane by default. You can switch the port on the MM910 SOL screen. <p>The BMC serial port and the serial port of the GE switching plane support the baud rate of 115,200 bit/s.</p> <p>The serial port of the FC switching plane supports the baud rate of 9,600 bit/s.</p>

Name	Type	Quantity	Subcard Number	Port Number	Description
GE electrical port	RJ45	12	17	The value ranges from 1 to 12. The port number starts from 1 in ascending order from bottom to top.	This port is used to exchange data with an external network. Each port has one indicator. When the indicator blinks green, it indicates the GE electrical port data transmission status. When the indicator is steady green, it indicates the GE electrical port connection status.
10GE optical port	SFP+	4	20	The value is 1 or 4. The port number starts from 1 in ascending order from bottom to top.	This port is used to exchange data with an external network and stacking devices. Two indicators are provided for each port. The amber indicator is the data transmission status indicator for the 10GE optical port, and the green indicator is the connection status indicator for the 10GE optical port.
8G FC port	SFP+	8	-	-	The FC switching plane provides eight 8G FC ports for connecting to the FC storage network. Each port has two indicators. The orange one is a data transmission status indicator, and the green one is a connection status indicator.

Table 1-4 describes the internal ports on the CX915 GE switching plane.

Table 1-4 Internal ports

Name	Type	Quantity	Subcard Number	Port Number	Description	Example
GE port	-	32	1 to 16	The value is 1 to 2.	This port is connected to half-width front slots 01 to 16. Each half-width slot maps to two port numbers.	If the CX915 is in slot 2X, the ports connected to the compute node in slot 1 are numbered GE 2/1/1 and GE 2/1/2.
GE port	-	2	19	The value is 1 to 2.	The two GE ports connect to and communicate with two MM910s. The two ports can communicate with the MM910s only when the switch module is in slot 2X or 3X.	If the CX915 is in slot 2X, the ports are numbered GE 2/19/1 and GE 2/19/2.

Table 1-5 describes the internal ports on the CX915 FC switching plane.

Table 1-5 Internal ports on the FC switching plane

Port	Type	Quantity	Description
FCoE port	Int1:12 to Int12:23	12	The ports are connected to half-width, front slots 1 to 12.
FC port	Int13:8 to Int16:11	4	The ports are connected to half-width, front slots 13 to 16.



1.5 Indicators



This topic describes the names, meanings, colors and status of the indicators on the CX915.

By observing the indicators, you can determine the current operating status of the CX915.

Table 1-6 describes the indicators on the CX915 panel.

Table 1-6 Indicator description

Label	Meaning	Color	Description
STAT	Stacking status indicator	Green	<ul style="list-style-type: none"> ● Off: The CX915 is not powered on. ● Blinking green for 10 times: The CX915 is being powered on. ● Blinking green: The CX915 is in the standby or slave state in a stack and is operating properly. ● Steady green: The CX915 is in the active state in a stack or is not stacked, and is operating properly.
HLY	Health indicator	Red and green	<ul style="list-style-type: none"> ● Off: The CX915 is not powered on. ● Steady green: The CX915 is operating properly or has minor alarms. ● Blinking red (1 Hz): A major alarm is generated. ● Blinking red (at 5 Hz): A critical alarm is generated for the CX915, or the CX915 is not securely installed.
OFL	Offline button/indicator (reserved)	N/A	None.
	GE electrical port indicator	Green	<ul style="list-style-type: none"> ● Off: The port is not properly connected. ● Blinking green: Data is being sent or received over the port. ● Steady green: The port is properly connected.
 and 	Connection status indicator for the 10GE optical port	Green	<ul style="list-style-type: none"> ● Off: The port is not properly connected. ● Steady green: The port is properly connected.

Label	Meaning	Color	Description
 and 	Data transmission status indicator for the 10GE optical port	Orange	<ul style="list-style-type: none"> ● Off: No data is being transmitted over the port. ● Blinking orange: Data is being sent or received over the port.
A	Data transmission status indicator for the 8G FC optical port	Orange	<ul style="list-style-type: none"> ● Off: No data is being transmitted over the port. ● Blinking orange (blinking every two seconds): If the green indicator (L) is blinking twice per second at the same time, a high temperature alarm is generated. ● Blinking orange (blinking twice per second): Data is being sent or received over the port.
L	Connection status indicator for the 8G FC optical port	Green	<ul style="list-style-type: none"> ● Off: No optical module is installed, or an exception occurs when the port is receiving optical signals. ● Steady green: The link properly connected. ● Blinking green (once/second): The device is registering or the port is in the diagnosis state. ● Blinking green (twice/second): The port is not properly connected or the port is faulty. If the orange indicator (A) is blinking twice per second at the same time, a high temperature alarm is generated.

1.6 Internal Chassis Networking

This topic describes connection relationships between the CX915 and mezz modules on compute nodes.

For details about the networking of the CX915 and Mezz cards on compute nodes, see [E9000 Blade Server Mezz Module-Switch Module Interface Mapping Tool](#).

Figure 1-6 shows the internal chassis networking for the CX915 and compute nodes. Ports on compute nodes for connecting to the CX915 are provided by two mezz modules as follows:

- Mezz 1 connects to the GE switching planes and FC switching planes of the CX915s in slots **2X** and **3X**.
- Mezz 2 connects to the GE switching planes and FC switching planes of the CX915s in slots **1E** and **4E**.

Figure 1-6 Mapping between the CX915 and mezz modules on compute nodes

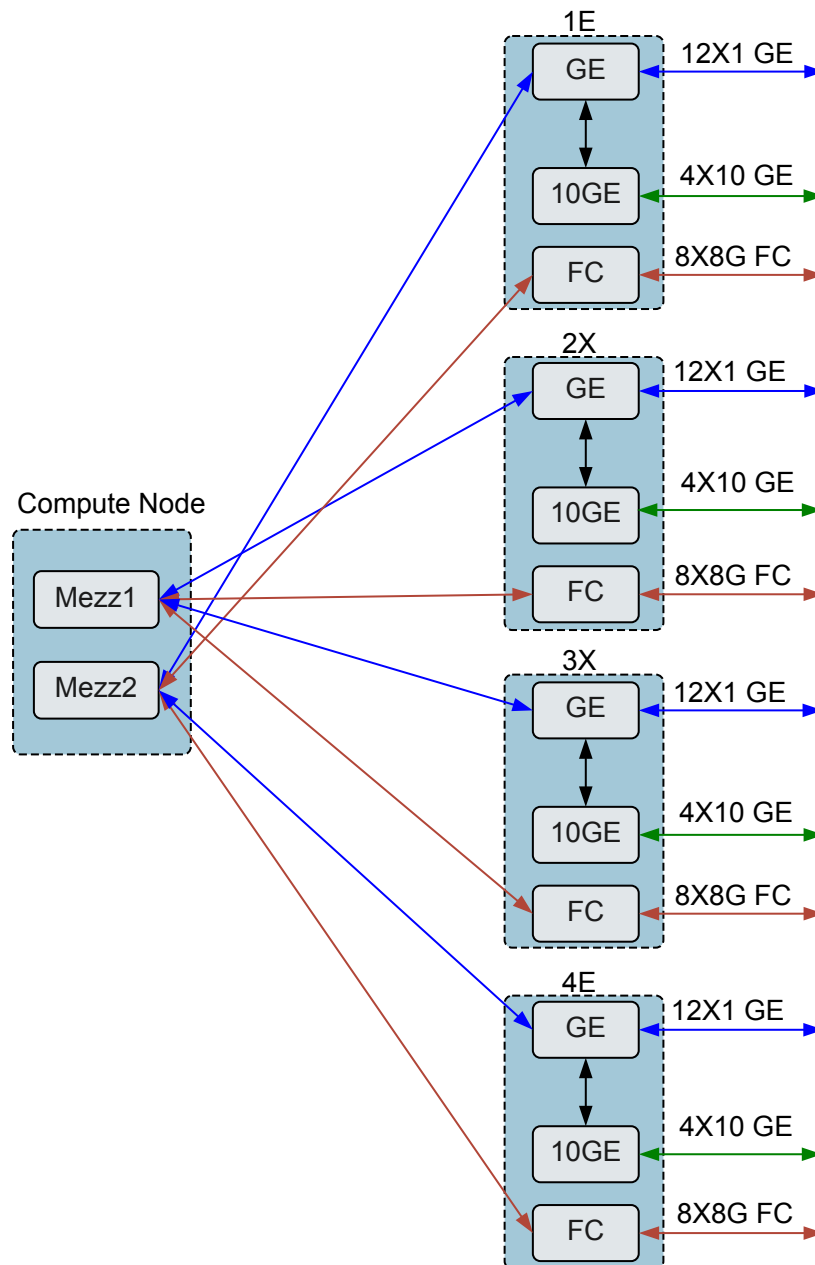

NOTE

If a compute uses the ports provided by four mezz modules to connect to the CX915, slots Mezz1 and Mezz3 connect to switch module slots 2X and 3X respectively, and slots Mezz2 and Mezz4 connect to switch module slots 1E and 4E respectively.

The following describes the mapping between the CX915s and mezz modules. For example, the CX915s are installed in slots 2X and 3X and connect to Mezz 1.

Port Mapping Between a Switch Module and a Mezz Module

Mapping between the CX915 and ports on the MZ910

The two 10GE ports (ports 1 and 2) on the MZ910 map to the GE switching planes of the CX915s in slots 3X and 2X respectively, as shown in [Figure 1-7](#).

NOTE

The two 10GE ports on the MZ910 are automatically negotiated to GE ports to connect to the CX915 GE switching plane.

The two 8G FC ports (ports 3 and 4) on the MZ910 map to the FC switching planes of the CX915s in slots 3X and 2X respectively, as shown in [Figure 1-7](#).

Figure 1-7 Mapping between the CX915 and ports on the MZ910

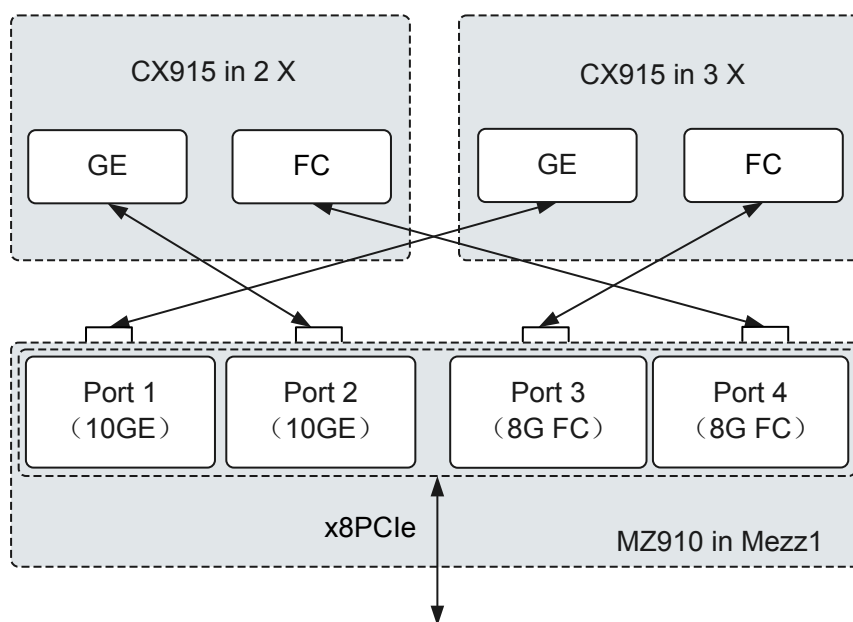

1.7 Software and Hardware Compatibility

This topic describes mezz modules that can work with the CX915 and pluggable modules and cables supported by ports on the CX915 panel.

For details about the software and hardware that are compatible with the CX915, see [Huawei Server Compatibility Checker](#).

Supported Mezz Modules

The CX915 connects to mezz modules of compute nodes. [Table 1-7](#) describes models and specifications of the supported mezz modules.

Table 1-7 Supported mezz modules

Model	Specifications
MZ910	FC mezzanine card with two 10GE ports and two 8G FC ports
MZ912	FC mezzanine card with two 10GE ports and two 16G FC ports

Supported Pluggable Modules and Cables

Table 1-8 Supported pluggable modules and cables

Module/Cable	Description
SFP+ multi-mode optical module (10GE)	Supports 10GBASE-SR.
SFP+ single-mode optical module (10GE)	Supports 10GBASE-LR.
DAC cable (10GE)	Supports 10GBASE-CR. The 7 m and 10 m active DAC cables or 1 m, 3 m, and 5 m passive DAC cables can be used.
SFP+ multi-mode optical module (4G/8G)	Supports FC-PI-4.
SFP+ single-mode optical module (4G/8G)	Supports FC-PI-4.
SFP multi-mode optical module (GE)	Supports 1000BASE-SX.
SFP single-mode optical module (GE)	Supports 1000BASE-LX.
Multi-mode fiber (MMF)	Supports the MMF of 850 nm OM1/OM2/OM3.
Single-mode fiber (SMF)	Supports the 1310 SMF.
Cat-5 unshielded twisted pair (UTP) cable	Category 5 UTP cables that support RJ45 ports
Cat-5e UTP cable	Category 5e (Category 5 enhanced) UTP cables that support RJ45 ports
Console cable	Supports the RJ45 port and serves as the connection cable for RS232 serial ports.

CX915 supports multiple pluggable optical modules, fibers, and network cables. You can choose the modules and cables based on site requirements.

- The CX915 provides the following functions for GE applications:
 - Provides SFP+ optical ports and supports single-mode and multi-mode SFP+ optical modules.
 - Provides RJ45 ports, supports 10/100/1000 Mbit/s autonegotiation, and uses twisted pair cables for connection.
- The CX915 provides the following functions for 10GE applications:
 - Provides SFP+ optical ports and supports single-mode and multi-mode SFP+ optical modules.
 - Supports 10GE DAC cables, which can be 7 m or 10 m active DAC cables or 1 m, 3 m, or 5 m passive DAC cables.
- The CX915 provides the following functions for FC applications: provides SFP+ optical ports that supports 8G or 4G SFP optical modules that are single-mode or multi-mode.

1.8 Technical Specifications

This topic describes the physical, environmental, power, and network switching specifications of the CX915.

[Table 1-9](#) describes the technical specifications of the CX915, and [Table 1-10](#) describes the network switching specifications of the CX915.

For details about the FC switching plane switching performance, see the [MX510 Mezz Module QuickTool User Guide](#).

Table 1-9 Technical specifications

Category	Item	Specifications
Physical specifications	Dimensions (H x W x D)	388.55 mm x 35.06 mm x 272.15 mm (15.30 in. x 1.38 in. x 10.71 in.)
	Color	Silver white
	Weight	2.7 kg
Environmental specifications	Temperature	<ul style="list-style-type: none">● Operating temperature: 5°C to 40°C (41°F to 104°F) (ASHRAE Class A3 compliant)● Storage temperature: -40°C to +65°C (-40°F to +149°F)● Long-term storage temperature: 21°C to 27°C (69.8°F to 80.6°F)
	Temperature change rate	15°C/h (27°F/h)

Category	Item	Specifications
	Humidity	<ul style="list-style-type: none"> ● Operating humidity: 5% RH to 85% RH (non-condensing) ● Storage humidity: 5% RH to 95% RH (non-condensing) ● Long-term storage humidity: 30% RH to 69% RH (non-condensing)
	Altitude	<p>At an altitude of 900 m (2952.72 ft), the highest operating temperature is 40°C (104°F).</p> <p>When the device is used at an altitude of 900 m to 5000 m, the highest operating temperature decreases by 1°C (1.8°F) as the altitude increases by 300 m (984.24 ft).</p>
Input power supply	Rated input voltage	12 V DC
Power consumption	Maximum power consumption	125 W

Table 1-10 Network switching specifications

Item	Description	Specifications
Quantity of ports on the panel	26	<ul style="list-style-type: none"> ● One BMC serial port and one SYS serial port ● Twelve GE electrical ports ● Four 10GE optical ports ● Eight 8 Gbit/s FC optical ports
Port rate	<ul style="list-style-type: none"> ● GE switching plane: GE or 10GE ● FC switching plane: 4G FC and 8G FC optical ports 	Full duplex mode
Switching capability (throughput)	<ul style="list-style-type: none"> ● GE switching plane: 172 Gbit/s ● FC switching plane: 384 Gbit/s 	-
MAC address filtering	GE switching plane: 1024	-
Capacity of the MAC address table	GE switching plane: 32768	-

Item	Description	Specifications
Quantity of VLANs	GE switching plane: 4063	Complies with IEEE 802.1Q.
Jumbo frame length (in byte)	GE switching plane: 1536-12288 frames	-
Priority queues	GE switching plane: 8	Complies with IEEE 802.1D.

2 Standards and Certifications

About This Chapter

[2.1 Standards Compliance](#)

This topic describes the international and industrial standards and communication protocols that the CX915 complies with.

[2.2 Certifications](#)

This topic describes the certifications that the E9000 has passed.

2.1 Standards Compliance

This topic describes the international and industrial standards and communication protocols that the CX915 complies with.

International Standards

Table 2-1 lists the international standards.

Table 2-1 Standards and protocol compliance

Standard	Protocol
FC-DA	FC Device Attach
FC-FS-2	FC Framing and Signaling
FC-GS-5	FC Generic Service
FC-LS	FC Link ServiceFC Link Service
FC-MI-2	FC Methodologies for Interconnects
FC-PI-4	FIBRE CHANNEL. Physical Interface-4 8G FC Interface
FC-SW-4	FC Switch Fabric
FC-VI	FC Virtual Interface Architecture Mapping
FCP-3	Fibre Channel Protocol for SCSI
IEEE 802.3x	Flow control and Back pressure
IEEE 802.3z	1000BASE-X Gbit/s Ethernet over Fiber-Optic at 1 Gbit/s
IEEE 802.3ab	1000BASE-T Gigabit Ethernet overcopper wiring
IEEE 802.3aq	10GBASE-LRM 10 Gbit/s Ethernet over multimode fiber
IEEE 802.1Q	Virtual Bridged Local Area Networks(VLAN)
IEEE 802.1s	Multiple Spanning Trees(MSTP)
IEEE 802.1w	Rapid Reconvergence of Spanning Tree (RSTP)
IEEE 802.1ab	Station and Media Access Control Connectivity Discovery (LLDP)
IEEE 802.1ad	Virtual Bridged Local Area Networks:Provider Bridges(QinQ)
IEEE 802.3ad	LinkAggregationControlProtocol(LACP)
IEEE 802.1Qbg	Edge Virtual Bridging(VEPA)
RFC2837	Fabric Element MIB Specification
SFF-8431	Enhanced Small Form Factor Pluggable Module SFP+

Standard	Protocol
SFF-8472	Diagnostic Monitoring Interface for Optical Transceivers

Industrial Standards

Table 2-2 lists the industrial standards.

Table 2-2 Industrial standards

Organization	Standard
ECMA TR/70	Environment protection
EN60950	Safety (Europe)
GR-929	Reliability
IEC 863	Reliability, maintainability, and availability compliance standard
IEC60297	Chassis compliance
IEC60950	Safety
IEC60825-1/2/6	Safety
IEC60215	Safety
IEC61000	EMC standard
Telcordia SR-332	Reliability
UL60950	Safety (North America)

Communication Protocols

Table 2-3 lists the communication protocols.

Table 2-3 Communication protocols

Protocol	Description
ARP	Address Resolution Protocol
BFD	Bidirectional Forwarding Detection
BGP	Border Gateway Protocol
DHCP	Dynamic Host Configuration Protocol
DLDP	Device Link Detection Protocol
FTP	File Transfer Protocol (By default, it is disabled. You can run a command to enable it.)

Protocol	Description
GMRP	GARP Multicast Registration Protocol
GVRP	GARP VLAN Registration Protocol
HTTP	Hypertext Transfer Protocol
ICMP	Internet Control Message Protocol
IGMP	Internet Group Management Protocol
IP	Internet Protocol
IPMI	Intelligent Platform Management Interface
IPv4/IPv6	IPv4/IPv6 Internet Protocol
MSTP	Multiple Spanning Tree Protocol
NTP	Network Time Protocol
OSPF	Open Shortest Path First
RADIUS	Remote Authentication Dial In User Service
RIP	Routing Information Protocol
RSTP	Rapid Spanning Tree Protocol
SNMP	Simple Network Management Protocol
SSH	Secure Shell
SSL	Secure Socket Layer
STP	Rapid Spanning Tree Protocol
TCP	Transmission Control Protocol
TELNET	Remote terminal protocol
TFTP	Trivial File Transfer Protocol
UDP	User Datagram Protocol
VRRP	Virtual Router Redundancy Protocol

2.2 Certifications

This topic describes the certifications that the E9000 has passed.

[Table 2-4](#) lists the certifications.

Table 2-4 Certifications

Country /Region	Certification	Standard
Europe	WEEE	2002/96/EC, 2012/19/EU
Europe	RoHS	2002/95/EC, 2011/65/EU, EN 50581: 2012
Europe	REACH	EC NO. 1907/2006
Europe	CE	Safety: EN 60950-1: 2006+A11: 2009+A1: 2010+A12: 2011 EMC: <ul style="list-style-type: none"> ● EN 55022: 2010 ● CISPR 22: 2008 ● EN 55024: 2010 ● CISPR 24: 2010 ● ETSI EN 300 386 V1.6.1: 2012 ● ETSI ES 201 468 V1.3.1: 2005
China	RoHS	SJ/T-11363-20006 SJ/T-11364-20006 GB/T 26572-2011
China	China Environmental Labeling	GB/T24024: 2001 idt ISO14024: 1999 HJ 2507-2011
Australia	C-tick	AS/NZS CISPR22: 2009
America	UL	UL 60950-1
America	FCC	FCC Part 15 (Class A)
America	NTRL-UL	UL 60950-1, 2nd Edition, 2011-12-19 (Information Technology Equipment - Safety - Part 1: General Requirements) CSA C22.2 No.60950-1-07, 2nd Edition, 2011-12 (Information Technology Equipment-Safety-Part 1: General Requirements)
Canada	IC	ICES-003 Class A
Nigeria	SONCAP	IEC 60950-1: 2005 (2nd Edition) + A1: 2009 EN 60950-1: 2006+A11: 2009+A1: 2010 + A12: 2011
Kingdom of Saudi Arabia (KSA)	SASO	IEC 60950-1: 2005 (2nd Edition) + A1: 2009 EN 60950-1: 2006+A11: 2009+A1: 2010 + A12: 2011
Global	CB	IEC 60950-1
Japan	VCCI	VCCI V-4: 2012