

**Huawei CX912 Switch Module  
V100R001C10**

**White Paper**

**Issue** 13  
**Date** 2017-06-08

**Copyright © Huawei Technologies Co., Ltd. 2017. All rights reserved.**

No part of this document may be reproduced or transmitted in any form or by any means without prior written consent of Huawei Technologies Co., Ltd.

## **Trademarks and Permissions**



HUAWEI and other Huawei trademarks are trademarks of Huawei Technologies Co., Ltd.

All other trademarks and trade names mentioned in this document are the property of their respective holders.

## **Notice**

The purchased products, services and features are stipulated by the contract made between Huawei and the customer. All or part of the products, services and features described in this document may not be within the purchase scope or the usage scope. Unless otherwise specified in the contract, all statements, information, and recommendations in this document are provided "AS IS" without warranties, guarantees or representations of any kind, either express or implied.

The information in this document is subject to change without notice. Every effort has been made in the preparation of this document to ensure accuracy of the contents, but all statements, information, and recommendations in this document do not constitute a warranty of any kind, express or implied.

## **Huawei Technologies Co., Ltd.**

Address: Huawei Industrial Base  
Bantian, Longgang  
Shenzhen 518129  
People's Republic of China

Website: <http://e.huawei.com>

# About This Document

## Purpose

This document describes the E9000 CX912 multi-plane switch module (CX912 for short) in terms of its functions, advantages, appearance, specifications, internal networking, standards and certifications. You can learn about the CX912 by reading this document.

The product features and commands for the 10GE switching plane of the CX912 vary according to the software version. For details, see the documents listed in the following table.

Huawei Support Website Version	10GE Switching Plane Software Version	Reference Document
V100R001C00 or V100R001C00SPCxxx	1.1.0.200.3	See the <i>Huawei CX912 Switch Module V100R001C00 White Paper</i> .
	1.1.3.300.5	
	1.1.3.301.6	
	1.2.1.0.19	
	1.2.1.0.21	
	2.23	
	2.26	
	2.29	
V100R001C10 or V100R001C10SPCxxx	1.2.1.0.39	See this guide.
	x.xx, for example, 2.05, excepting 2.23, 2.26, and 2.29	





## Intended Audience

This document is intended for:

- Huawei presales engineers
- Channel partner presales engineers
- Huawei enterprise presales engineers

## Symbol Conventions

The symbols that may be found in this document are defined as follows.

Symbol	Description
 <b>DANGER</b>	<b>DANGER</b> indicates a hazard with a high level or medium level of risk which, if not avoided, could result in death or serious injury.
 <b>WARNING</b>	<b>WARNING</b> indicates a hazard with a low level of risk which, if not avoided, could result in minor or moderate injury.
 <b>CAUTION</b>	<b>CAUTION</b> indicates a potentially hazardous situation that, if not avoided, could result in equipment damage, data loss, performance deterioration, or unanticipated results.
 <b>TIP</b>	<b>TIP</b> indicates a tip that may help you solve a problem or save time.
 <b>NOTE</b>	<b>NOTE</b> provides additional information to emphasize or supplement important points of the main text.

## Change History

### Issue 13 (2017-06-08)

This issue is the thirteenth official release.

Mode	Change Description
Modified	Deleted the contents about FCoE in <a href="#">1.1 Functions</a> , <a href="#">1.2 Advantages</a> , <a href="#">1.6 Internal Chassis Networking</a> .

### Issue 12 (2017-03-27)

This issue is the twelfth official release.

Mode	Change Description
Added	Added product model descriptions to <a href="#">1.3 Appearance</a> .
Modified	Modified the relationships between switching plane software versions and reference documents in About This Document.

## Issue 11 (2017-02-17)

This issue is the eleventh official release.

Mode	Change Description
Modified	Changed the altitude in <a href="#">1.8 Technical Specifications</a> .

## Issue 10 (2016-11-22)

This issue is the tenth official release.

Mode	Change Description
Added	Added the description about the working temperature's compliance with the ASHRAE Class A3 standard in <a href="#">1.8 Technical Specifications</a> .

## Issue 09 (2016-05-12)

This issue is the ninth official release.

Mode	Change Description
Added	Added the long-term storage temperature and humidity to <a href="#">1.8 Technical Specifications</a> .
	In <a href="#">1.7 Software and Hardware Compatibility</a> , the following note is added: FC ports of the CX912 support only single-mode and multi-mode Brocade swappable optical modules.
	In <a href="#">1.6 Internal Chassis Networking</a> , the connection relationships with the MZ912 are added.
Deleted	In <a href="#">1.6 Internal Chassis Networking</a> , the connection relationships with the MZ311, MZ510, MZ512, and MZ910 are added.

## Issue 08 (2015-07-17)

This issue is the eighth official release.

Mode	Change Description
Modified	The reference to the throughput is added to <a href="#">1.8 Technical Specifications</a> .

## Issue 07 (2015-03-20)

This issue is the seventh official release.

## Issue 06 (2015-02-16)

This issue is the sixth official release.

Mode	Change Description
Modified	The reference to the Networking Assistant is added to <b>1.6 Internal Chassis Networking</b> .

## Issue 05 (2015-02-26)

This issue is the fifth official release.

Mode	Change Description
Modified	The figure in <b>1.6 Internal Chassis Networking</b> is updated.

## Issue 04 (2014-09-15)

This issue is the fourth official release.

Mode	Change Description
Deleted	"Teecal" is deleted from the product document.

## Issue 03 (2014-05-13)

This issue is the third official release.

## Issue 02 (2014-04-08)

This issue is the second official release.

## Issue 01 (2014-01-02)

This issue is the first official release.

---

# Contents

---

<b>About This Document.....</b>	<b>ii</b>
<b>1 Overview.....</b>	<b>1</b>
1.1 Functions.....	2
1.2 Advantages.....	10
1.3 Appearance.....	11
1.4 Ports.....	15
1.5 Indicators.....	20
1.6 Internal Chassis Networking.....	22
1.7 Software and Hardware Compatibility.....	24
1.8 Technical Specifications.....	26
<b>2 Standards and Certifications.....</b>	<b>30</b>
2.1 Standards Compliance.....	31
2.2 Certifications.....	33

# 1 Overview

---

## About This Chapter

### [1.1 Functions](#)

This topic describes the functions, supported protocols, and ports of the switching planes of the CX912 multi-plane switch module (CX912 for short).

### [1.2 Advantages](#)

The CX912 switch module provides high performance, high port density, and multiple switching planes (GE/10GE/Fibre Channel(FC) switching), and supports large data center networks, high-performance stacking, on-demand configuration, flexible deployment, and rich data center features. In addition, the CX912 switch module is easy to deploy and maintain.

### [1.3 Appearance](#)

This topic describes the CX912 in terms of its appearance, panel, and installation positions in the chassis.

### [1.4 Ports](#)

This topic describes the features, numbering rules, names, types, and quantities of the CX912 ports.

### [1.5 Indicators](#)

This topic describes the indicators on the CX912.

### [1.6 Internal Chassis Networking](#)

This topic describes connection relationships between the CX912 and mezz modules on compute nodes.

### [1.7 Software and Hardware Compatibility](#)

This topic describes mezz modules that can work with the CX912 and pluggable modules and cables supported by ports on the CX912 panel.

### [1.8 Technical Specifications](#)

This topic describes the physical, environmental, power, and network switching specifications of the CX912.



## 1.1 Functions

This topic describes the functions, supported protocols, and ports of the switching planes of the CX912 multi-plane switch module (CX912 for short).

CX912 is the switching control unit of a server. It provides data switching for compute nodes in the system and external management network ports and service ports. The CX912 provides two independent planes, including the 10GE switching plane, and FC switching plane. The two planes are physically isolated.

The CX912 is installed in a rear slot of the E9000 chassis and is connected to compute nodes, storage nodes, and management modules through the midplane. It exchanges internal data packets and control and management packets to ensure high-speed data transmission.

For details about the functions provided by the 10GE switching plane, see [Table 1-1](#). For details about the functions provided by the FC switching plane, see [Table 1-2](#).

**Table 1-1** 10GE switching plane function description

Function		Description
Ethernet features	Ethernet	<ul style="list-style-type: none"> <li>● Operating modes of full-duplex and auto-negotiation</li> <li>● Ethernet ports support: 10GE.</li> </ul> <p><b>NOTE</b></p> <ul style="list-style-type: none"> <li>● 10GE optical ports support passive direct attached cables (DACs).</li> <li>● 10GE optical ports support GE and 10GE multi-mode and single-mode optical modules.</li> <li>● 10GE optical ports support SFP electrical modules.</li> </ul> <ul style="list-style-type: none"> <li>● Port traffic control</li> </ul> <p><b>NOTE</b></p> <p>10GE optical interfaces do not support flow control.</p> <ul style="list-style-type: none"> <li>● Jumbo frames</li> <li>● Link aggregation</li> <li>● Load balancing among links within a trunk</li> <li>● Interface isolation and forwarding restrictions</li> <li>● Broadcast storm suppression</li> </ul>
	Virtual Local Area Network (VLAN)	<ul style="list-style-type: none"> <li>● Access modes of access, trunk, and hybrid</li> <li>● VLAN assignment: port-based, MAC address-based, IP subnet-based VLAN assignment</li> <li>● VLAN aggregation</li> <li>● Multiplex VLAN (MUX VLAN)</li> <li>● Transparent Transmission of Protocol Packets in a VLAN</li> </ul>

Function		Description
	802.1Q in 802.1Q (QinQ)	<ul style="list-style-type: none"> <li>● Basic QinQ</li> <li>● Selective QinQ</li> </ul>
	VLAN Mapping	<ul style="list-style-type: none"> <li>● 1 to 1 VLAN mapping.</li> <li>● 2 to 1 VLAN mapping.</li> <li>● 2 to 2 VLAN mapping.</li> </ul>
	Media Access Control (MAC)	<ul style="list-style-type: none"> <li>● Secure MAC addresses</li> <li>● Automatic learning and aging of MAC addresses</li> <li>● Static, dynamic, and blackhole MAC address entries</li> <li>● Packet filtering based on source MAC addresses</li> <li>● Interface-based MAC learning limits</li> </ul>
	Link Layer Discovery Protocol (LLDP)	Support for LLDP
Ethernet loop protection	Multiple Spanning Tree Protocol (MSTP)	<ul style="list-style-type: none"> <li>● Spanning Tree Protocol (STP)</li> <li>● Rapid Spanning Tree Protocol (RSTP)</li> <li>● MSTP</li> <li>● Bridge protocol data unit (BPDU) protection, root protection, and loop protection</li> <li>● Partitioned STP and Layer 2 protocol transparent transmission</li> </ul>
IP features	Address Resolution Protocol (ARP)	<ul style="list-style-type: none"> <li>● Static and dynamic ARP entries</li> <li>● ARP in a VLAN</li> <li>● Aging of ARP entries</li> <li>● ARP and Reverse Address Resolution Protocol (RARP)</li> <li>● ARP proxy</li> <li>● Auto-detection</li> </ul>
	IPv6	<ul style="list-style-type: none"> <li>● IPv4/IPv6 dual-stack</li> <li>● Neighbor Discovery (ND)</li> <li>● IPv6 over IPv4 Manual Tunnel</li> <li>● IPv6 over IPv4 Generic Routing Encapsulation (GRE) Tunnel</li> <li>● 6to4 Tunnel</li> </ul>

Function		Description
	Dynamic Host Configuration Protocol (DHCP)	<ul style="list-style-type: none"> <li>● DHCP server</li> <li>● DHCP snooping</li> <li>● DHCP relay</li> <li>● DHCPv6 Relay</li> </ul>
IP forwarding	Unicast routing features	<ul style="list-style-type: none"> <li>● IPv4/IPv6 static routing</li> <li>● Routing Information Protocol version 1 (RIP-1), RIP-2, and RIP next generation (RIPng)</li> <li>● Open Shortest Path First (OSPF), including OSPFv2 and OSPFv3</li> <li>● Intermediate System to Intermediate System (IS-IS)</li> <li>● Border Gateway Protocol 4.0 (BGP4) and Border Gateway Protocol for IPv6 (BGP4+)</li> <li>● Routing protocol</li> <li>● Policy-based routing</li> <li>● Unicast Reverse Path Forwarding (URPF) check</li> </ul>
	Virtual Private Network (VPN) features	<ul style="list-style-type: none"> <li>● Multi-VPN-Instance CE (MCE) and IPv6 MCE</li> <li>● GRE Tunnel</li> </ul>
	Multicast routing features	<ul style="list-style-type: none"> <li>● Internet Group Management Protocol version 1/2/3 (IGMPv1/v2/v3)</li> <li>● Protocol Independent Multicast - Sparse Mode (PIM-SM) for IPv4 and IPv6</li> <li>● Protocol Independent Multicast Source-Specific Multicast (PIM-SSM) for IPv4 and IPv6</li> <li>● Multicast Listener Discovery version 1 and 2 (MLDv1 and MLDv2)</li> <li>● MLD Source-Specific Multicast (SSM) Mapping</li> <li>● Multiprotocol BGP (MBGP)</li> <li>● Multicast Source Discovery Protocol (MSDP)</li> <li>● Multicast routing policies</li> <li>● Reverse Path Forwarding (RPF)</li> <li>● Bidirectional PIM (IPv4) and Bidirectional PIM (IPv6)</li> </ul>

Function		Description
Device reliability	Bidirectional Forwarding Detection (BFD)	<ul style="list-style-type: none"> <li>● BFD (IPv4) and BFD (IPv6)</li> <li>● Association between BFD and Eth-Trunk</li> <li>● Association between BFD and OSPF</li> <li>● Association between BFD and OSPFv3</li> <li>● Association between BFD and IS-IS</li> <li>● Association between BFD and IS-IS IPv6</li> <li>● Association between BFD and BGP</li> <li>● Association between BFD and BGP4+</li> <li>● Association between BFD and PIM (IPv4)</li> <li>● Association between BFD and PIM (IPv6)</li> <li>● Association between BFD and static routing (IPv4)</li> <li>● Association between BFD and static routing (IPv6)</li> <li>● Association between BFD and Virtual Router Redundancy Protocol (VRRP)</li> <li>● Association between BFD and VRRP6</li> </ul>
	Others	<ul style="list-style-type: none"> <li>● Virtual Router Redundancy Protocol (VRRP) and VRRP6</li> <li>● Device Link Detection Protocol (DLDP)</li> <li>● Smart Link</li> <li>● Smart Channel</li> <li>● Ethernet in the First Mile (EFM), defined in 802.3ah</li> </ul>
Layer 2 multicast features	Layer 2 multicast features	<ul style="list-style-type: none"> <li>● IGMP snooping</li> <li>● IGMP proxy</li> <li>● Fast leave</li> <li>● Multicast traffic control</li> <li>● Multicast VLAN</li> </ul>
Quality of Service (QoS) features	Traffic classification	<ul style="list-style-type: none"> <li>● Traffic classification based on combination of the L2 protocol header, IP 5-tuple, outbound interface, and 802.1p priority</li> <li>● Traffic classification based on the C-VLAN and C-PRI of QinQ packets</li> </ul>

Function		Description
	Traffic behavior	<ul style="list-style-type: none"> <li>● Access control after traffic classification</li> <li>● Traffic policing based on traffic classifiers</li> <li>● Re-marking based on the traffic classification result</li> <li>● Class-based packet queuing</li> <li>● Association between traffic classifiers and traffic behavior (actions)</li> </ul>
	Queue scheduling	<ul style="list-style-type: none"> <li>● Priority queuing (PQ) scheduling</li> <li>● Deficit round robin (DRR) scheduling</li> <li>● PQ+DRR scheduling</li> <li>● Weighted round robin (WRR) scheduling</li> <li>● PQ+WRR scheduling</li> </ul>
	Congestion avoidance	Weighted Random Early Detection (WRED)
	Rate limiting on outbound interfaces	Rate limiting on outbound interfaces
Virtualization	Many-to-one virtualization	<ul style="list-style-type: none"> <li>● Intelligent Stack (iStack)</li> <li>● Stack split and merge</li> <li>● Dual-active detection</li> <li>● Version and configuration synchronization</li> </ul>
Data center features	Transparent Interconnection of Lots of Links (TRILL)	<ul style="list-style-type: none"> <li>● TRILL features</li> <li>● TRILL Non-Stop Routing (NSR)</li> <li>● TRILL Equal-Cost Multi-Path (ECMP)</li> <li>● IGMP over TRILL</li> <li>● TRILL multi-homing active-active</li> </ul>
	Data Center Bridging (DCB)	<ul style="list-style-type: none"> <li>● Data Center Bridging Exchange Protocol (DCBX)</li> <li>● Priority-based Flow Control (PFC)</li> <li>● Enhanced Transmission Selection (ETS)</li> </ul>
	Fibre Channel over Ethernet (FCoE)	FCoE Initialization Protocol Snooping Bridge (FSB)

Function		Description
	Virtual machine (VM) detection	<ul style="list-style-type: none"> <li>● Virtual awareness</li> <li>● Automatic policy deployment</li> <li>● Automatic policy migration</li> <li>● Network Load Balancing (NLB) server cluster                             <ul style="list-style-type: none"> <li>- Association between virtual IP addresses of NLBs and multicast MAC addresses</li> <li>- Association between one multicast MAC address and multiple outbound interfaces</li> </ul> </li> </ul>
	Forwarding mode based on Virtual Ethernet Port Aggregator (VEPA)	Forwarding mode based on VEPA
Configuration and maintenance	Terminal service	<ul style="list-style-type: none"> <li>● Configuration using command lines</li> <li>● Error messages and online help in English and Chinese</li> <li>● Login through console and Telnet terminals</li> <li>● Send function and data communications between terminal users</li> </ul>
	File system	<ul style="list-style-type: none"> <li>● Directory and file management</li> <li>● File upload and download using File Transfer Protocol (FTP), Trivial File Transfer Protocol (TFTP) and Secure File Transfer Protocol (SFTP)</li> </ul>
	Debugging and maintenance	<ul style="list-style-type: none"> <li>● Unified management of logs, alarms, and debugging information</li> <li>● Electronic labels</li> <li>● User operation logs</li> <li>● Detailed debugging information for network fault diagnosis</li> <li>● Network test tools such as tracer and ping commands</li> <li>● Port mirroring and traffic mirroring</li> </ul>
	Version upgrade	<ul style="list-style-type: none"> <li>● Device software loading and in-service software loading</li> <li>● In-service upgrade using the basic input/output system (BIOS) menu</li> <li>● In-service patching</li> </ul> <p><b>NOTE</b> To ensure secure service application, periodically upgrade the switch module software version.</p>

Function		Description
Security and management	System security	<ul style="list-style-type: none"> <li>● Hierarchical command-line protection based on user levels, preventing unauthorized users from using commands to access switch modules</li> <li>● Secure Shell (SSH)</li> <li>● Remote Authentication Dial-In User Service (RADIUS) authentication over IPv4 or IPv6 for login users</li> <li>● Huawei Terminal Access Controller Access Control System (HWTACACS) authentication over IPv4 or IPv6 for login users</li> <li>● Access control list (ACL) filtering</li> <li>● Dynamic ARP inspection (DAI)</li> <li>● DHCP packet filtering (appending the Option 82 field)</li> <li>● Defense against control packet attacks</li> <li>● Defense against attacks of source address spoofing, LAND, SYN flood (TCP SYN), smurf, ping flood (Internet Control Message Protocol Echo), teardrop, and ping of death</li> <li>● Logs about attacking MAC addresses</li> </ul>
	Network management	<ul style="list-style-type: none"> <li>● Internet Control Message Protocol (ICMP)-based ping and tracer</li> <li>● Simple Network Management Protocol version 1/2c/3 (SNMPv1/v2c/v3)</li> <li>● Standard management information base (MIB)</li> <li>● Remote network monitoring (RMON)</li> <li>● NetStream, with output statistics packets in the V5, V8, or V9 format</li> <li>● sFlow</li> <li>● Network quality analysis(NQR)</li> </ul>

**Table 1-2** FC switching plane function description

Function		Description
Fibre Channel (FC) switching	FC optical port	Supports 4G/8G FC autonegotiation, full duplex.

Function		Description
	Switching	<ul style="list-style-type: none"> <li>● Supports the FC switching mode (Native) and access gateway mode (that is, NPV mode). NPV is short for N-Port virtualization.</li> <li>● Supports free mapping to the internal fibre channel (FC) ports and external FC ports in NPV mode.</li> <li>● Supports network connection between E_Ports and Brocade FC switches in FC mode. A license is required for the function.</li> </ul>
	NPIV	Supports N_Port ID virtualization (NPIV). A physical port supports access of multiple N_Port_IDs.
FC switching	Link aggregation	<p>Supports FC port multi-link aggregation to expand the port bandwidth and provide redundancy.</p> <ul style="list-style-type: none"> <li>● Supports connection only to Brocade FC switches.</li> <li>● Requires a license.</li> </ul>
Configuration and maintenance	Configuration and management modes	<ul style="list-style-type: none"> <li>● Supports configurations using command lines.</li> <li>● Supports the HTTPS-based Webtool (graphical user interface).</li> <li>● Simple Network Management Protocol version 1/3 (SNMPv1/v3).</li> <li>● Supports the FC Fabric Element management information base (MIB).</li> </ul>
	Connection mode	<ul style="list-style-type: none"> <li>● Ethernet connection (over SSH, SNMP, or the Web).</li> <li>● Serial over LAN (SOL) connection.</li> </ul>
	Version upgrade	<p>Supports online upgrades for software. Services are not interrupted during an upgrade. The upgrade takes effect after the restart.</p> <p><b>NOTE</b> To ensure secure service application, periodically upgrade the switch module software version.</p>



Function		Description
Network security	System security	<ul style="list-style-type: none"><li>● Hierarchical rights management based on user levels, preventing unauthorized users from accessing switch modules.</li><li>● Supports Secure Shell (SSH) and Secure Sockets Layer (SSL).</li><li>● Supports Hypertext Transfer Protocol Secure (HTTPS).</li><li>● Supports SNMPv1/v3.</li><li>● Supports Remote Authentication Dial In User Service (RADIUS) for user logins.</li><li>● Supports SSH login using the username and password or public and private keys.</li></ul>

## 1.2 Advantages

The CX912 switch module provides high performance, high port density, and multiple switching planes (GE/10GE/Fibre Channel(FC) switching), and supports large data center networks, high-performance stacking, on-demand configuration, flexible deployment, and rich data center features. In addition, the CX912 switch module is easy to deploy and maintain.

### High Performance and High Port Density

Underpinned by the leading hardware platform, the CX912 provides a high port density and a line-speed forwarding capability. It supports next-generation server applications that require super high performance and density.

The CX912 10GE switching plane provides sixteen 10GE SFP+ optical ports for connecting to upstream aggregation/core switches, forty 10GE electrical ports for interconnecting with high-performance compute nodes, eight 8G FC optical ports for connecting FC storage area networks (FC SANs), and two 40GE ports for interconnecting with switch modules.

The CX912 10GE switching planes support low-latency forwarding, providing a switching capability of 1.28 Tbit/s (throughput) and line-speed forwarding for Ethernet frames. The forwarding latency for layer 2 Ethernet frames in cut through mode is less than 1.5 us.

The CX912 FC switching plane provides a line-speed switching capability of 192 Gbit/s (384 Gbit/s throughput).

### Multiple Switching Planes and Support for Large Data Center Networks

The CX912 provides table entries of high specifications: a maximum of 131,072 MAC address entries and 16,384 forwarding information bases (FIBs) entries.

### High-Performance Stacking, Easy Deployment, and Simple Maintenance

The CX912 supports a stacking system of four devices. It has the following advantages:

- High performance: A single stacking system can provide more than thirty-two 10GE ports.
- High bandwidth: The stacking system supports 160Gbps stacking bandwidth.
- Easy deployment and maintenance:
  - Pre-deployment and offline configuration are supported. The system can be pre-planned and pre-configured. Devices can be added as required, supporting plug-and-play.
  - The slot ID of a device is the ID in the stacking system, facilitating identification and maintenance.
  - Indicators on the front panel indicate the role and status of a stacking system. The stacking system can be maintained without a terminal.
- Simple upgrade operations: The stacking system supports quick and automatic software upgrades, simplifying upgrade operations and reducing upgrade workload.
  - Rapid software upgrades: When two switch modules are stacked, the standby switch module is upgraded before the active switch module. This ensures that at least one switch module is operating.
  - Automatic software upgrades: When two switch modules are stacked, the software version is automatically synchronized from the active switch module to the standby one.

## On-Demand Configuration and Flexible Deployment

The FC switching plane of the CX912 provides eight 8G FC ports. Four of the ports are activated by default, and the other four ports require licenses for activation, which addresses diverse user needs.

## Rich Data Center Features

- Supports virtualization/virtual machine (VM) access.
  - Supports server virtualization, improving data center utilization.
  - Supports virtual sensors. During migration of VMs, network policies can be automatically migrated using virtual sensors so that network resources can be allocated as required. Working with the layer 2 network, VMs can be freely migrated within the data center.
- Supports the Transparent Interconnection of Lots of Links (TRILL) protocol.
  - Complying with the Internet Engineering Task Force (IETF) standard, the TRILL protocol supports ultra-large networks and flexible networking modes.
  - The TRILL protocol supports load balancing between paths, so that traffic can be shared by multiple paths according to service requirements.
  - The TRILL protocol supports fast network convergence. Any changes on the network can be quickly sensed and fast convergence is performed.

## 1.3 Appearance

This topic describes the CX912 in terms of its appearance, panel, and installation positions in the chassis.

### Appearance

**Figure 1-1** shows the CX912.

**Figure 1-1** CX912

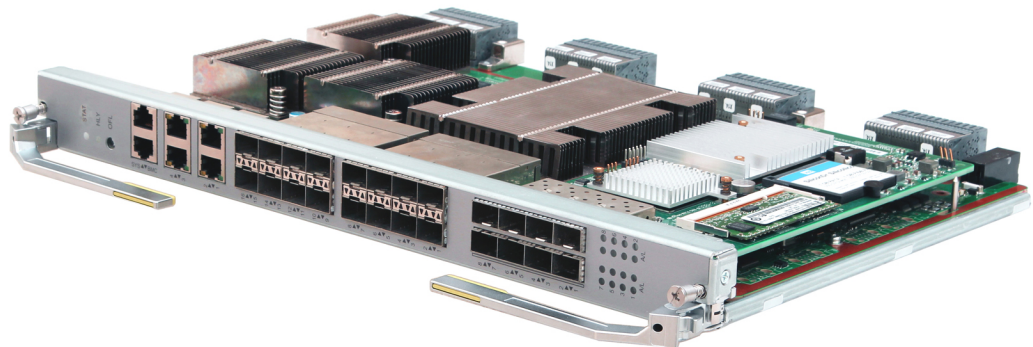

### Installation Positions

The CX912 can be installed in the four slots at the rear of the E9000 chassis. The four slots are 1E, 2X, 3X, and 4E, as shown in **Figure 1-2**.

**Figure 1-2** Installation positions and slots

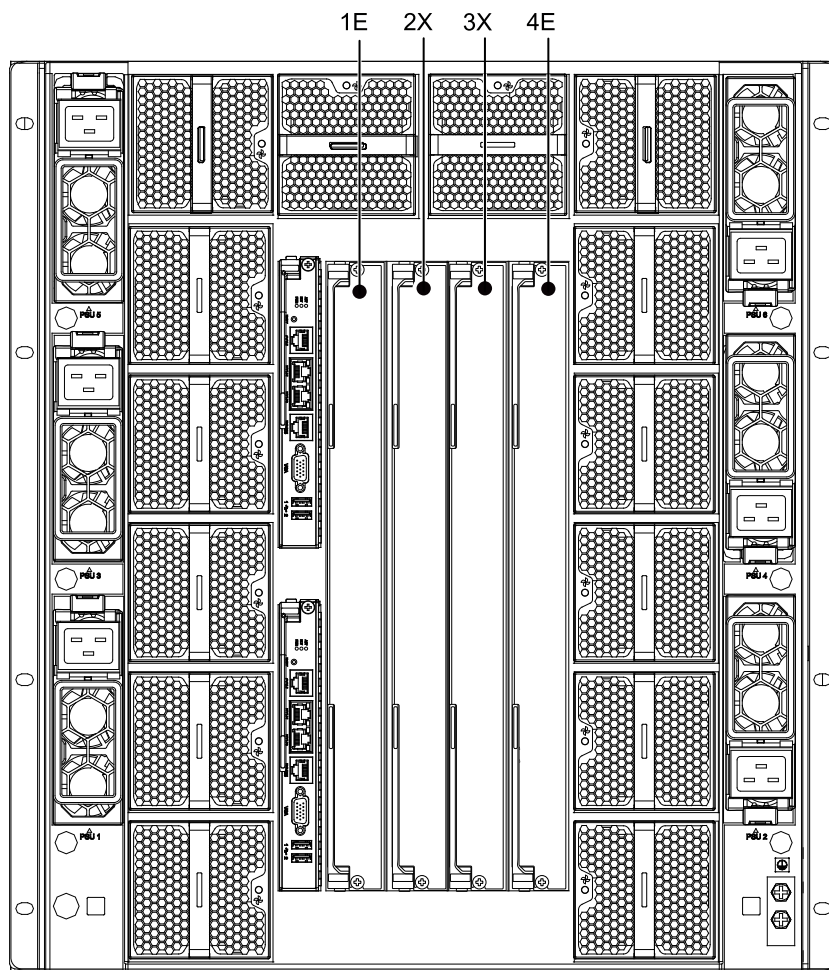

**Panel**

**Figure 1-3** shows the CX912 panel.

Figure 1-3 Panel

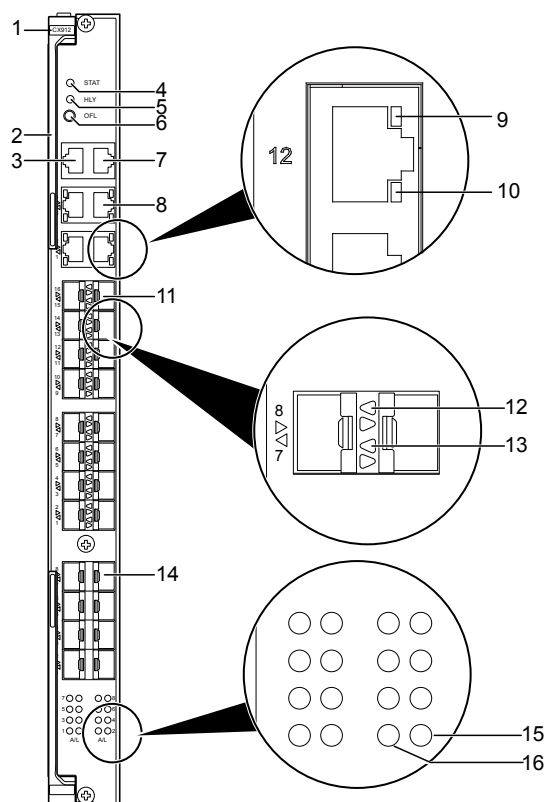

1	Product Model	2	Customization label (with an ESN label)
3	BMC serial port	4	Power indicator
5	Healthy indicator	6	Offline button/indicator
7	SYS serial port	8	GE electrical port (reserved)
9	Connection status indicator of the GE electrical port	10	Data transmission status indicator of the GE electrical port
11	10GE optical port	12	Connection status indicator of the 10GE optical port
13	Data transmission status indicator of the 10GE optical port	14	8G FC optical port
15	Connection status indicator of the 8G FC optical port	16	Diagnosis status indicator of the 8G FC optical port

**ESNs**

An Equipment Serial Number (ESN) is a string that uniquely identifies a server. An ESN is required when you apply for technical support from Huawei.

Figure 1-4 shows the ESN format.

**Figure 1-4** ESN example

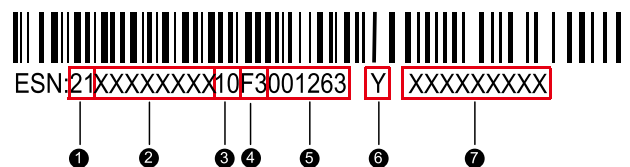

No.	Description
1	Indicates the ESN ID (two digits).
2	Indicates the item identification code (eight characters).
3	Indicates the vendor code (two characters).
4	Indicates the year and month (two characters). The first character indicates the year. Digits 1 to 9 indicate 2001 to 2009, and letters A to Z indicate 2010 to 2035. The second character indicates the month. Digits 1 to 9 indicate January to September, and letters A to C indicate October to December.
5	Indicates the sequence number (six digits).
6	Indicates RoHS compliance (one character).
7	Indicates the internal model number of the board.

## 1.4 Ports

This topic describes the features, numbering rules, names, types, and quantities of the CX912 ports.

The CX912 provides ports for users to operate and configure. The ports are used to send and receive data.

The CX912 ports are numbered in *Slot number/Subcard number/Port number* format.

- *Slot number*: indicates the slot number of the current switch module. Its value ranges from 1 to 4, from left to right mapping to slot numbers 1E, 2X, 3X, and 4E.
- *Subcard number*: indicates the number of a subcard supported by service ports. The value ranges from 1 to 19.
- *Port number*: indicates the sequence number of a port on a subcard.

The FC optical ports on the CX912 panel are numbered from 1 to 8.

For details about the value options, see [Figure 1-5](#), [Table 1-3](#), [Table 1-5](#) and [Table 1-6](#).

For example, if the CX912 is in slot 2X, the first GE optical port on the upper right of the panel is numbered GE 2/17/4, as shown in [Figure 1-5](#).

**Figure 1-5** Port naming rules

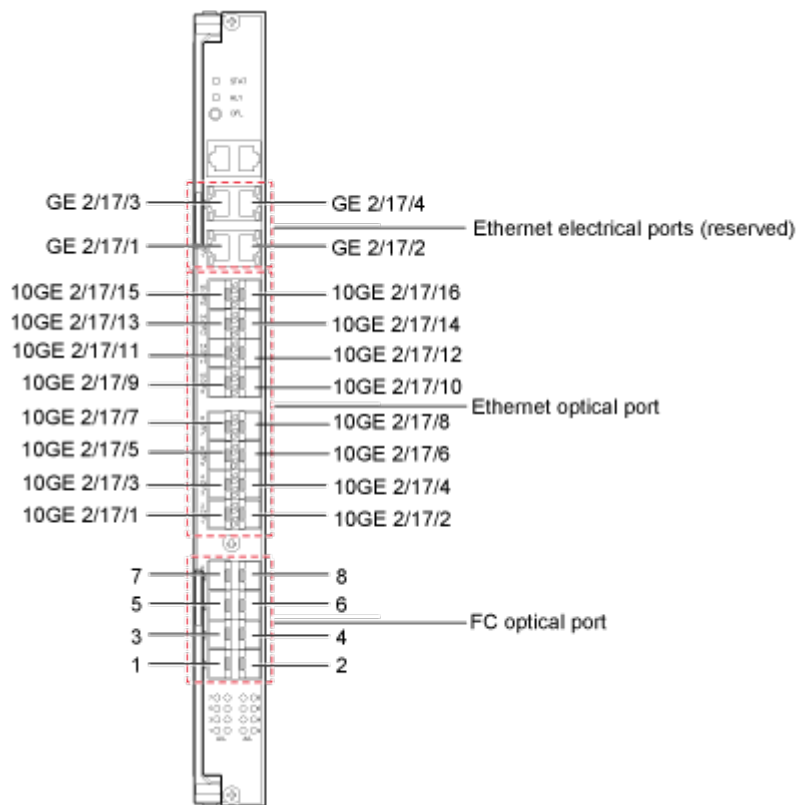

**Table 1-3** describes the ports on the CX912.

**Table 1-3** External ports

Port	Type	Quantity	Subcard Number	Port Number	Description
Serial port	RJ-45	RJ-45	-	-	<p>The serial ports include the baseboard management controller (BMC) serial port and the SYS serial port. The ports comply with RS232, and the port type is RJ45. No indicator is available.</p> <ul style="list-style-type: none"> <li>● BMC serial port: The port is used to log in to the BMC command-line interface (CLI).</li> <li>● SYS serial port: This port is used for managing, maintaining, and commissioning the 10GE switching plane and fibre channel (FC) switching plane.</li> </ul> <p>The BMC serial port and serial ports of the and 10GE switching plane support the baud rate of 115,200 bit/s.</p> <p>The serial port of the FC switching plane supports the baud rate of 9,600 bit/s.</p>
GE electrical port	RJ-45	4	17	The value ranges from 1 to 4.	<p>The onboard GE switching plane provides four GE ports for server control and management.</p> <p>Each port has two indicators. The orange one is a data transmission status indicator, and the green one is a connection status indicator.</p>



Port	Type	Quantity	Subcard Number	Port Number	Description
10GE optical port	SFP+	16	17	The value ranges from 1 to 16.	The 10GE switching plane provides sixteen 10GE ports for external network switching. Each port has two indicators. The orange one is a 10GE optical port data transmission status indicator, and the green one is a 10GE optical port connection status indicator.
8G FC optical port	SFP+	8	-	-	The FC switching plane provides eight 8G FC ports for connecting to the FC storage network. Ports 1 to 4 are activated by default, and ports 5 to 8 require licenses for activation. Each port has two indicators. The orange one is a diagnosis status indicator, and the green one is a connection status indicator.

**Table 1-4** describes the internal ports on the onboard GE switching plane of the CX912.

**Table 1-4** Internal ports on the onboard GE switching plane

Port	Type	Quantity	Subcard Number	Interface Number	Description	Example
GE port	-	16	1 to 16	The value is 1.	The ports connect to the front half-width slots 1 to 16, and map to subcard numbers from 1 to 16. The ports are reserved and cannot be used currently.	If the CX912 is in slot 2X, the port connected to the compute node in slot 1 is numbered GE 2/1/1.

Port	Type	Quantity	Subcard Number	Interface Number	Description	Example
GE port	-	2	19	The value ranges from 1 to 2.	Two GE ports connect to two MM910s respectively. They are used to communicate with the eth0 and eth2 in the internal MM910.  The two ports can communicate with the MM910s only when the switch module is in slot 2X or 3X.	If the CX912 is in slot 2X, the ports are numbered GE 2/19/1 and GE 2/19/2.
10GE port	-	1	18	The value is 1.	The port is used for interconnecting onboard GE switching planes of switch modules in slots 1E and 4E, or in slots 2X and 3X.	If the CX912 is in slot 2X, the port is numbered 10GE 2/18/1.

**Table 1-5** describes the internal ports on the CX912 10GE switching plane.

**Table 1-5** Internal ports on the 10GE switching plane

Port	Type	Quantity	Subcard Number	Port Number	Description	Example
10GE port	-	40	1 - 16	The value is <b>1</b> or <b>2</b> , or ranges from 1 to 3.	The port connects to half-width, front slots 1 to 16. Half-width slots 1 to 8 each connects to three 10GE ports. The port numbers are from 1 to 3. Half-width slots 9 to 16 each connects to two 10GE ports. The ports are numbered 1 and 2.	If the CX912 is in slot 2X, the ports connected to the compute node in slot 1 are numbered 10GE 2/1/1, 10GE 2/1/2, and 10GE 2/1/3.
40GE port	-	2	18	The value is <b>1</b> or <b>2</b> .	The port is used for interconnecting 10GE switching planes of switch modules in slots 1E and 4E, or in slots 2X and 3X.	If the CX912 is in slot 2X, the ports are numbered 40GE 2/18/1 and 40GE 2/18/2.

**Table 1-6** describes the internal ports on the CX912 FC switching plane.

**Table 1-6** Internal ports on the FC switching plane

Port	Port Number	Quantity	Description
FC port	0	1	The port is connected to the half-width, front slot 16.
FC port	9 to 23	15	The ports are connected to half-width, front slots 1 to 15.

 **NOTE**



The internal FC interface rate must be set to 8 Gbit/s.

## 1.5 Indicators

This topic describes the indicators on the CX912.

You can observe the indicators to determine the current operating status of the CX912. [Table 1-7](#) describes the indicators on the CX912 panel.

**Table 1-7** Indicators

Silkscreen	Meaning	Color	Description
STAT	Stacking status indicator	Green	<ul style="list-style-type: none"> <li>● Off: The CX912 is not powered on.</li> <li>● Blinking green for 10 times: The CX912 is being powered on.</li> <li>● Blinking green: The CX912 is standby in stacking mode and is operating properly.</li> <li>● Steady green: The CX912 is active in stacking mode or is not stacked, and is working properly.</li> </ul>
HLY	Healthy indicator	Red and green	<ul style="list-style-type: none"> <li>● Off: The CX912 is not powered on.</li> <li>● Steady green: The CX912 is working properly.</li> <li>● Blinking red (1 Hz): A major alarm is generated.</li> <li>● Blinking red (4 Hz): A critical alarm is generated.</li> <li>● Blinking red (5 Hz): The CX912 is not securely installed.</li> </ul>
OFL	Offline button/ indicator (reserved)	N/A	None.
	Data transmission status indicator of the 10GE optical port	Orange	<ul style="list-style-type: none"> <li>● Off: No data is being transmitted over the port.</li> <li>● Blinking orange: Data is being sent or received over the port.</li> </ul>
	Connection status indicator of the 10GE optical port	Green	<ul style="list-style-type: none"> <li>● Off: The port is not properly connected.</li> <li>● Steady green: The port is properly connected.</li> </ul>

Silkscreen	Meaning	Color	Description
A	Diagnosis status indicator of the 8G FC optical port	Orange	<ul style="list-style-type: none"> <li>● Off: No optical module is installed, or an exception occurs when the port is receiving optical signals. (The L indicator is also off.)</li> <li>● Steady orange: The port is not synchronized, and a connection exception occurs.</li> <li>● Blinking orange (once/2 seconds): The port is disabled.</li> <li>● Blinking orange (twice/second): The port is faulty.</li> </ul>
L	Connection status indicator of the 8G FC optical port	Green	<ul style="list-style-type: none"> <li>● Off: No optical module is installed, or an exception occurs when the port is receiving optical signals. (The A indicator is also off.)</li> <li>● Steady green: The port is normal, and the link is connected.</li> <li>● Blinking green (once/2 seconds): The port is normal but isolated. No link is set up.</li> <li>● Blinking green (twice/second): The port is in the diagnosis state.</li> <li>● Blinking green (four times/second): The link is properly set up and the port is transmitting data.</li> </ul>

## 1.6 Internal Chassis Networking

This topic describes connection relationships between the CX912 and mezz modules on compute nodes.

For details about the networking of the CX912 and mezzanine cards on compute nodes, see [E9000 Blade Server Mezz Module-Switch Module Interface Mapping Tool](#).

**Figure 1-6** shows the internal chassis networking for the CX912 and compute nodes. Ports on compute nodes for connecting to the CX912 are provided by two mezz modules. The mapping between the CX912 and the NIC and mezz modules is described as follows:

- Mezz 1 connects to the 10GE switching planes and FC switching planes of the CX912s in slots **2X** and **3X**.
- Mezz 2 connects to the 10GE switching planes and FC switching planes of the CX912s in slots **1E** and **4E**.

**Figure 1-6** Mapping between the CX912 and mezz modules on compute nodes

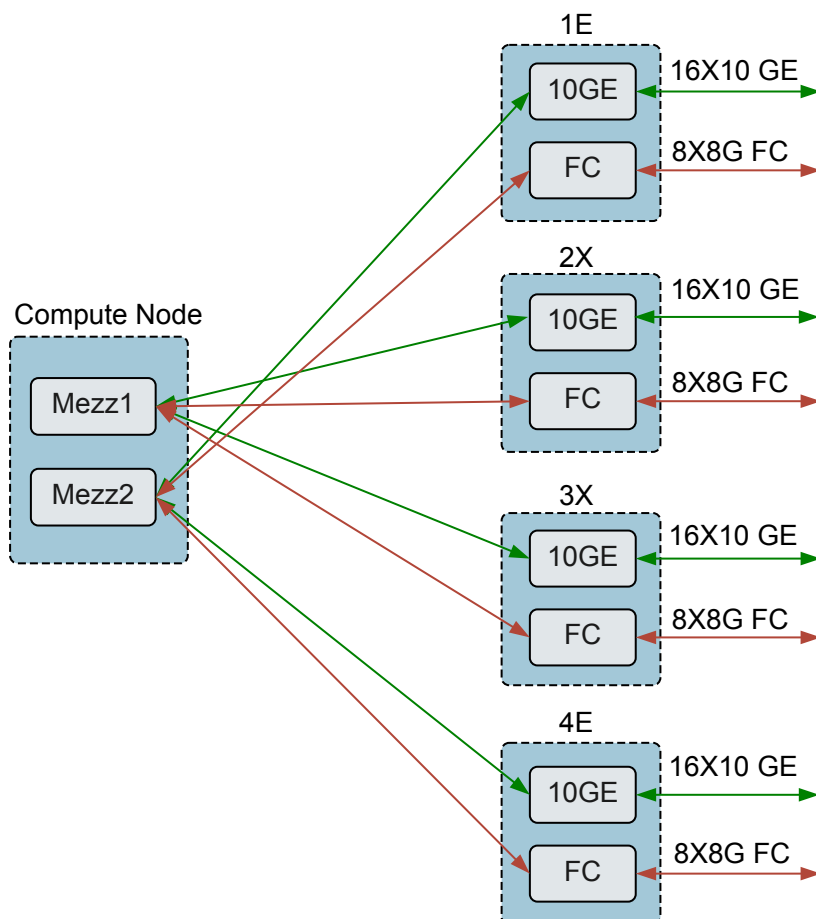

### Mapping between the CX912 and ports on the MZ912

The two 10GE ports (ports 1 and 2) on the MZ910 map to the 10GE switching planes of the CX912s in slots **3X** and **2X** respectively, as shown in [Figure 1-7](#).

The 8G FC ports (ports 3 and 4) on the MZ912 map to the FC switching planes of the CX912s in slots **3X** and **2X** respectively.

**Figure 1-7** Mapping between the CX912 and ports on the MZ912

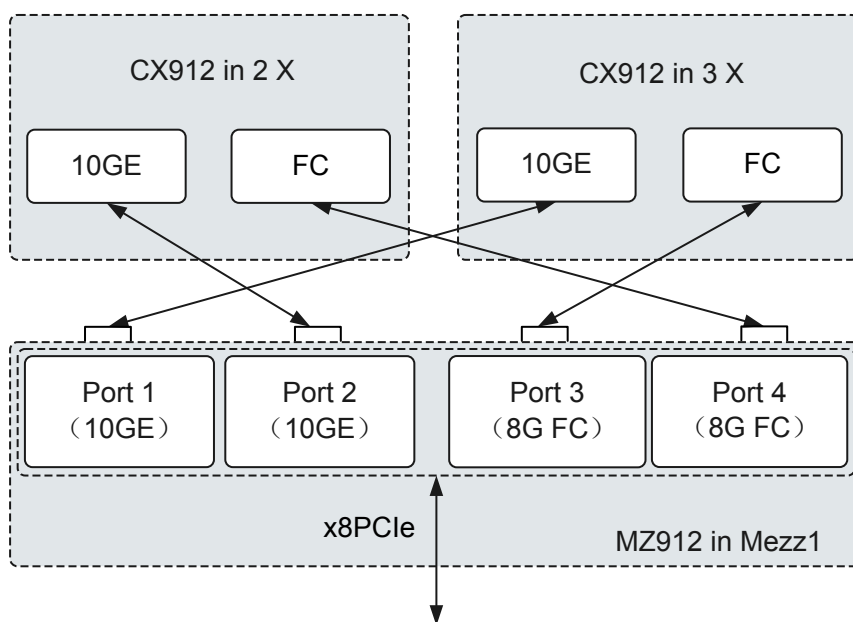

## 1.7 Software and Hardware Compatibility

This topic describes mezz modules that can work with the CX912 and pluggable modules and cables supported by ports on the CX912 panel.

For details about the software and hardware that are compatible with the CX912, see [Huawei Server Compatibility Checker](#).

### Supported Mezz Modules

The CX912 connects to mezz modules of compute nodes. [Table 1-8](#) describes models and specifications of the supported mezz modules.

**Table 1-8** Supported mezz modules

Model	Specifications
MZ910	FC mezzanine card with two 10GE ports and two 8G FC ports
MZ912	4-port multi-function mezzanine card (2x 10GE + 2 x 16G FC)

## Supported Pluggable Modules and Cables

**Table 1-9** Supported pluggable modules and cables

Module/Cable	Description
SFP+ multi-mode optical module (10GE)	Supports 10GBASE-SR.
SFP+ single-mode optical module (10GE)	Supports 10GBASE-LR.
DAC cable (10GE)	Supports 10GBASE-CR. 7 m or 10 m active DAC cables or 1 m, 3 m, or 5 m passive DAC cables can be used.
SFP+ multi-mode optical module (8G) (Brocade SFP+ optical modules only)	Supports FC-PI-4.
SFP+ single-mode optical module (8G) (Brocade SFP+ optical modules only)	Supports FC-PI-4.
SFP multi-mode optical module (GE)	Supports 1000BASE-SX.
SFP single-mode optical module (GE)	Supports 1000BASE-LX.
SFP electrical module (GE)	An electrical module, supporting the RJ45 port and 1000BASE-T (10/100 Mbit/s is not supported)
Multi-mode fiber (MMF)	Supports the MMF of 850 nm OM1/OM2/OM3.
Single-mode fiber (SMF)	Supports the 1310 SMF.
Cat-5 unshielded twisted pair (UTP) cable	Category 5 UTP cables that support RJ45 ports
Cat-5e UTP cable	Category 5e (Category 5 enhanced) UTP cables that support RJ45 ports
Console cable	Supports the RJ45 port and serves as the connection cable for RS232 serial ports.
Note: The table is for reference only. For details about the components that can be purchased, consult the local Huawei sales representatives.	

The CX912 supports multiple pluggable optical modules, fibers, and network cables. You can choose the modules and cables based on site requirements.

- The CX912 provides the following functions for GE applications:
  - Provides RJ45 ports for connecting to twisted-pair cables.
  - Provides SFP+ optical ports that support single-mode and multi-mode SFP+ optical modules.



- Supports SFP electrical modules.
- The CX912 provides the following functions for 10GE applications:
  - Provides SFP+ optical ports and supports single-mode and multi-mode SFP+ optical modules.
  - Supports 10GE DAC cables, which can be 7 m or 10 m active DAC cables or 1 m, 3 m, or 5 m passive DAC cables.
- The CX912 provides the following functions for FC applications: provides SFP+ optical ports; uses single-mode and multi-mode 8G SFP+ optical modules; supports 4 Gbit/s and 8 Gbit/s.

 **NOTE**

FC ports of the CX912 support only single-mode and multi-mode Brocade swappable optical modules.

## 1.8 Technical Specifications

This topic describes the physical, environmental, power, and network switching specifications of the CX912.

**Table 1-10** describes the technical parameters of the CX912, and **Table 1-11** describes the network switching specifications of the CX912.

For details about the FC switching plane switching performance, see the [MX210&MX220\\_Fabric\\_OS\\_Administrator\\_Guide](#).

**Table 1-10** Technical specifications

Category	Item	Specifications
Physical specifications	Dimensions (H x W x D)	388.55 mm x 35.06 mm x 272.15 mm (15.30 in. x 1.38 in. x 10.71 in.)
	Color	Silver
	Weight	3.5 kg
Environmental specifications	Temperature	<ul style="list-style-type: none"> <li>● Operating temperature: 5°C to 40°C (41°F to 104°F) (ASHRAE Class A3 compliant)</li> <li>● Storage temperature: -40°C to +65°C (-40°F to +149°F)</li> <li>● Long-term storage temperature: 21°C to 27°C (69.8°F to 80.6°F)</li> </ul>
	Temperature change rate	15°C/h (27°F/h)
	Humidity	<ul style="list-style-type: none"> <li>● Operating humidity: 5% RH to 85% RH (non-condensing)</li> <li>● Storage humidity: 5% RH to 95% RH (non-condensing)</li> <li>● Long-term storage humidity: 30% RH to 69% RH (non-condensing)</li> </ul>

Category	Item	Specifications
	Altitude	At an altitude of 900 m (2952.72 ft), the highest operating temperature is 40°C (104°F). When the device is used at an altitude of 900 m to 5000 m, the highest operating temperature decreases by 1°C (1.8°F) for every increase of 300 m (984.24 ft).
Input power supply	Rated input voltage	12 V DC
Power consumption	Maximum power consumption	178 W 154 W

**Table 1-11** Network switching specifications

Attribute	Service Feature	Specifications
Device performance	Number of ports on the panel	<ul style="list-style-type: none"> <li>● One BMC serial port and one SYS serial port</li> <li>● Sixteen 10GE optical ports</li> <li>● Eight 8 Gbit/s FC optical ports</li> </ul>
	Port rate	<ul style="list-style-type: none"> <li>● The 10GE switching plane supports 10GE and GE optical ports.</li> <li>● FC switching plane supports 8G FC optical ports.</li> </ul>
	Service port stacking	Four 10GE ports on the panel or one 40GE ports on two switch modules can be stacked (10GE ports and 40GE ports cannot be stacked into one logical interface.)
	Switching capability (throughput)	<ul style="list-style-type: none"> <li>● 10GE switching plane: 1.28 Tbit/s</li> <li>● FC switching plane: 384 Gbit/s</li> </ul>
	Packet forwarding rate	960Mpps
Ethernet service	Number of Media Access Control (MAC) addresses	131,072

Attribute	Service Feature	Specifications
	Number of VLANs	4063 <b>NOTE</b> A switch module reserves 31 internal virtual local area networks (VLANs). The default value ranges from 4064 to 4094. The range of consecutive VLANs must be reserved for configuration.
	Number of Eth-Trunk interfaces	128 Eth-Trunk interfaces, with each Eth-Trunk interface supports a maximum of 16 member interfaces
	Number of Address Resolution Protocols (ARPs) for the device	16384
	Jumbo frame length (in byte)	9216 byte
Quality of service (QoS)	Number of queues for a port	8
	Number of Committed Access Rate(CAR)	<ul style="list-style-type: none"> <li>● Ingress: 2048</li> <li>● Egress: 1024</li> </ul>
	Packet cache	4 MB
ACL	ACLv4	<ul style="list-style-type: none"> <li>● Pre-Ingress: 750</li> <li>● Ingress: 1500</li> <li>● Egress: 1000</li> </ul>
L3VPN	VPN routing and forwarding(VRF )	128 (MPLS is not supported) MPLS is short for Multiprotocol Label Switching.
	Number of virtual private network (VPN) routes	16384
IP address unicast	Number of route entries	16384
	Number of IPV4 forwarding information bases (FIBs)	16384

Attribute	Service Feature	Specifications
	Number of IPV6 FIBs	8000 (The subnet mask length is less than or equal to 64 bits)
Multicast	Number of layer 3 multicast forwarding entries	2000
Reliability service	Bidirectional Forwarding Detection (BFD)	<ul style="list-style-type: none"> <li>● Number of BFD sessions: 128</li> <li>● Minimum interval for transmitting and receiving packets: 50 ms</li> </ul>
	Virtual Router Redundancy Protocol (VRRP)	<ul style="list-style-type: none"> <li>● Number of VRRP backup groups: 64</li> <li>● Number of VRRP management groups: 64</li> <li>● Number of virtual IP addresses for each VRRP backup group: 16</li> </ul>
	Multiple Spanning Tree Protocol (MSTP)	Maximum number of instances in the device: 64
Enhanced Ethernet	Transparent Interconnection of Lots of Links (TRILL)	<ul style="list-style-type: none"> <li>● Number of network nodes: 512</li> <li>● Number of CE-VLANs: 4062</li> <li>● Load-sharing specifications: 16 links</li> </ul>

# 2 Standards and Certifications

---

## About This Chapter

### [2.1 Standards Compliance](#)

This topic describes the international and industrial standards and communication protocols that the CX912 complies with.

### [2.2 Certifications](#)

This topic describes the certifications that the E9000 has passed.

## 2.1 Standards Compliance

This topic describes the international and industrial standards and communication protocols that the CX912 complies with.

### International Standards

[Table 2-1](#) lists the international standards.

**Table 2-1** Standards and protocol compliance

Standard	Protocol
DCBX	Data Center Bridging eXchange
FC-DA	FC Device Attach
FC-FS-2	FC Framing and Signaling
FC-GS-5	FC Generic Service
FC-LS	FC Link ServiceFC Link Service
FC-MI-2	FC Methodologies for Interconnects
FC-PI-4	FIBRE CHANNEL. Physical Interface-4 8G FC port
FC-SW-4	FC Switch Fabric
FC-VI	FC Virtual Interface Architecture Mapping
FCP-3	Fibre Channel Protocol for SCSI
IEEE 802.3x	Flow control and Back pressure
IEEE 802.3z	1000BASE-X Gbit/s Ethernet over Fiber-Optic at 1 Gbit/s
IEEE 802.3aq	10GBASE-LRM 10 Gbit/s Ethernet over multimode fiber
IEEE 802.1Qbb	Priority-based Flow Control (PFC)
IEEE 802.1Qaz	Enhanced Transmission Selection(ETS)
IEEE 802.1Q	Virtual Bridged Local Area Networks(VLAN)
IEEE 802.1s	Multiple Spanning Trees(MSTP)
IEEE 802.1w	Rapid Reconvergence of Spanning Tree (RSTP)
IEEE 802.1ab	Station and Media Access Control Connectivity Discovery(LLDP)
IEEE 802.1ad	Virtual Bridged Local Area Networks:Provider Bridges(QinQ)
IEEE 802.3ad	LinkAggregationControlProtocol(LACP)
IEEE 802.1Qbg	Edge Virtual Bridging(VEPA)
IEEE 1149.1-2001	IEEE Standard Test Acces Port and Boundary-Scan Architecture

Standard	Protocol
RFC2837	Fabric Element MIB Specification
SFF-8431	Enhanced Small Form Factor Pluggable Module SFP+
SFF-8472	Diagnostic Monitoring Interface for Optical Transceivers

## Industrial Standards

**Table 2-2** lists the industrial standards.

**Table 2-2** Industrial standards

Organization	Standard
ECMA TR/70	Environmental protection
EN60950	Safety (Europe)
GR-929	Reliability
IEC 812	Failure Mode and Effects Analysis(FMEA)
IEC 863	Reliability, maintainability, and availability compliance standard
IEC60297	Chassis compliance
IEC60950	Safety
IEC60825-1/2/6	Safety
IEC60215	Safety
IEC61000	EMC standard
Telcordia SR-332	Reliability
UL60950	Safety (North America)

## Communication Protocols

**Table 2-3** lists the communication protocols.

**Table 2-3** Communication protocols

Protocol	Description
ARP	Address Resolution Protocol
BFD	Bidirectional Forwarding Detection
BGP	Border Gateway Protocol

Protocol	Description
DHCP	Dynamic Host Configuration Protocol
DLDP	Device Link Detection Protocol
FTP	File Transfer Protocol
GMRP	GARP Multicast Registration Protocol
GVRP	GGARP VLAN Registration Protocol
HTTP	Hypertext Transfer Protocol
ICMP	Internet Control Message Protocol
IGMP	Internet Group Management Protocol
IPMI	Intelligent Platform Management Interface
IPv4/IPv6	IPv4/IPv6 Internet Protocol
MSTP	Multiple Spanning Tree Protocol
NTP	Network Time Protocol
OSPF	Open Shortest Path First
RADIUS	Remote Authentication Dial In User Service
RIP	Routing Information Protocol
RSTP	Rapid Spanning Tree Protocol
SNMP	Simple Network Management Protocol
SSH	Secure Shell
SSL	Secure Socket Layer
STP	Spanning Tree Protocol
TCP	Transmission Control Protocol
TELNET	Remote terminal protocol
TFTP	Trivial File Transfer Protocol
TRILL	Transparent Interconnection of Lots of Links
UDP	User Datagram Protocol
VRRP	Virtual Router Redundancy Protocol

## 2.2 Certifications

This topic describes the certifications that the E9000 has passed.

[Table 2-4](#) lists the certifications.



**Table 2-4** Certifications

Country /Region	Certification	Standard
Europe	WEEE	2002/96/EC, 2012/19/EU
Europe	RoHS	2002/95/EC, 2011/65/EU, EN 50581: 2012
Europe	REACH	EC NO. 1907/2006
Europe	CE	Safety: EN 60950-1: 2006+A11: 2009+A1: 2010+A12: 2011 EMC: <ul style="list-style-type: none"> <li>● EN 55022: 2010</li> <li>● CISPR 22: 2008</li> <li>● EN 55024: 2010</li> <li>● CISPR 24: 2010</li> <li>● ETSI EN 300 386 V1.6.1: 2012</li> <li>● ETSI ES 201 468 V1.3.1: 2005</li> </ul>
China	RoHS	SJ/T-11363-20006 SJ/T-11364-20006 GB/T 26572-2011
China	China Environmental Labeling	GB/T24024: 2001 idt ISO14024: 1999 HJ 2507-2011
Australia	C-tick	AS/NZS CISPR22: 2009
America	UL	UL 60950-1
America	FCC	FCC Part 15 (Class A)
America	NTRL-UL	UL 60950-1, 2nd Edition, 2011-12-19 (Information Technology Equipment - Safety - Part 1: General Requirements) CSA C22.2 No.60950-1-07, 2nd Edition, 2011-12 (Information Technology Equipment-Safety-Part 1: General Requirements)
Canada	IC	ICES-003 Class A
Nigeria	SONCAP	IEC 60950-1: 2005 (2nd Edition) + A1: 2009 EN 60950-1: 2006+A11: 2009+A1: 2010 + A12: 2011
Kingdom of Saudi Arabia (KSA)	SASO	IEC 60950-1: 2005 (2nd Edition) + A1: 2009 EN 60950-1: 2006+A11: 2009+A1: 2010 + A12: 2011
Global	CB	IEC 60950-1
Japan	VCCI	VCCI V-4: 2012