



**Huawei CX610 Switch Module  
V100R001**

**White Paper**

**Issue**     **07**  
**Date**       **2017-03-27**

**Copyright © Huawei Technologies Co., Ltd. 2017. All rights reserved.**

No part of this document may be reproduced or transmitted in any form or by any means without prior written consent of Huawei Technologies Co., Ltd.

## **Trademarks and Permissions**



HUAWEI and other Huawei trademarks are trademarks of Huawei Technologies Co., Ltd.

All other trademarks and trade names mentioned in this document are the property of their respective holders.

## **Notice**

The purchased products, services and features are stipulated by the contract made between Huawei and the customer. All or part of the products, services and features described in this document may not be within the purchase scope or the usage scope. Unless otherwise specified in the contract, all statements, information, and recommendations in this document are provided "AS IS" without warranties, guarantees or representations of any kind, either express or implied.

The information in this document is subject to change without notice. Every effort has been made in the preparation of this document to ensure accuracy of the contents, but all statements, information, and recommendations in this document do not constitute a warranty of any kind, express or implied.

## **Huawei Technologies Co., Ltd.**

Address: Huawei Industrial Base  
Bantian, Longgang  
Shenzhen 518129  
People's Republic of China

Website: <http://e.huawei.com>

# About This Document

## Purpose

This document describes the E9000 CX610 IB switch module (CX610 for short) in terms of its functions, advantages, appearance, specifications, internal networking, standards and certifications. You can learn about the CX610 by reading this document.





## Intended Audience

This document is intended for:

- Huawei presales engineers
- Channel partner presales engineers
- Huawei enterprise presales engineers

## Symbol Conventions

The symbols that may be found in this document are defined as follows.

Symbol	Description
 <b>DANGER</b>	<b>DANGER</b> indicates a hazard with a high level or medium level of risk which, if not avoided, could result in death or serious injury.
 <b>WARNING</b>	<b>WARNING</b> indicates a hazard with a low level of risk which, if not avoided, could result in minor or moderate injury.
 <b>CAUTION</b>	<b>CAUTION</b> indicates a potentially hazardous situation that, if not avoided, could result in equipment damage, data loss, performance deterioration, or unanticipated results.
 <b>TIP</b>	<b>TIP</b> indicates a tip that may help you solve a problem or save time.
 <b>NOTE</b>	<b>NOTE</b> provides additional information to emphasize or supplement important points of the main text.

## Change History

### Issue 07 (2017-03-27)

This issue is the seventh official release.

Mode	Change Description
Added	Added product model descriptions to Appearance.

### Issue 06 (2017-02-17)

This issue is the sixth official release.

Mode	Change Description
Modified	Changed the altitude in <a href="#">1.8 Technical Specifications</a> .
Modified	Modified the internal networking diagram of the chassis in <a href="#">1.6 Internal Chassis Networking</a>
Added	Added the description about the working temperature's compliance with the ASHRAE Class A3 standard in <a href="#">1.8 Technical Specifications</a> .
Added	Added the long-term storage temperature and humidity to <a href="#">1.8 Technical Specifications</a> .

### Issue 05 (2014-09-11)

This issue is the fifth official release.

Mode	Change Description
Deleted	"Tecal" is deleted from the product document.

### Issue 04 (2014-07-30)

This issue is the fourth official release.

Mode	Change Description
Modified	The storage temperature and altitude are updated in <a href="#">1.8 Technical Specifications</a> .

### Issue 03 (2014-03-07)

This issue is the third official release.

## Issue 02 (2013-11-18)

This issue is the second official release.

Mode	Change Description
Modified	The HLY indicator description is added to <b>1.5 Indicators</b> .

## Issue 01 (2013-08-30)

This issue is the first official release.

---

# Contents

---

<b>About This Document.....</b>	<b>ii</b>
<b>1 Overview.....</b>	<b>1</b>
1.1 Functions.....	2
1.2 Advantages.....	2
1.3 Appearance.....	2
1.4 Ports.....	5
1.5 Indicators.....	6
1.6 Internal Chassis Networking.....	7
1.7 Software and Hardware Compatibility.....	9
1.8 Technical Specifications.....	10
<b>2 Standards and Certifications.....</b>	<b>12</b>
2.1 Standards Compliance.....	13
2.2 Certifications.....	14

# 1 Overview

---

## About This Chapter

### [1.1 Functions](#)

This topic describes the functions and ports of the CX610 switch module.

### [1.2 Advantages](#)

This topic describes the advantages of the CX610 switch module.

### [1.3 Appearance](#)

This topic describes the CX610 in terms of its appearance, panel, and installation positions in the chassis.

### [1.4 Ports](#)

This topic describes the name, type, quantity, description, and the naming rules of the ports on the CX610.

### [1.5 Indicators](#)

This topic describes the names, meanings, colors, descriptions and working status of the indicators on the CX610.

### [1.6 Internal Chassis Networking](#)

This topic describes the networking between the CX610 and other devices in the chassis.

### [1.7 Software and Hardware Compatibility](#)

This topic describes the software and hardware supported by the CX610.

### [1.8 Technical Specifications](#)

This topic describes the physical, environmental, and power specifications of the CX610.

## 1.1 Functions

This topic describes the functions and ports of the CX610 switch module.

The E9000 CX610 Switch Module (CX610 for short) is the Infiniband (IB) switch module of the E9000 server and provides external IB ports for the compute nodes, storage nodes, or service process nodes installed in the front slots of the E9000. Each CX610 provides up to 18 IB ports on the panel and up to 16 IB ports on the backplane. It also can monitor the hardware operating, software operating and operating environment.

## 1.2 Advantages

This topic describes the advantages of the CX610 switch module.

The CX610 switch module provides various ports (14G bit/s, 40 Gbit/s, and 56 Gbit/s) and delivers high performance.

### Various Ports (14 Gbit/s, 40 Gbit/s, and 56 Gbit/s)

Underpinned by the leading hardware platform, the CX610 provides high-density ports and a line-speed forwarding capability.

CX610 provides the external ports as follows:

- SYS serial port: The serial port is used to debug the small system and the baud rate of 115200 bit/s.
- BMC serial port: The serial port is used to debug the baseboard management controller (BMC) module and the baud rate of 115200 bit/s.
- 18 QSFP+ ports: These ports are used to connect to the external network and provide FDR10 signal. One green indicator is provided for each port.

CX610 provides 16 FDR ports for connecting to the mezzanine cards on the 16 half-width or eight full-width nodes.

### High Performance

The CX610 has the following advantages in performance:

- 100 Gbit/s bandwidth
- 6.8 TB switching capacity
- 90 ns time delay
- A built-in switch chip and NIC, removing the need for cables
- Co-Design Scalable Hierarchical Aggregation and Reduction Protocol (SHARP)

## 1.3 Appearance

This topic describes the CX610 in terms of its appearance, panel, and installation positions in the chassis.



## Appearance

**Figure 1-1** shows the CX610.

**Figure 1-1** Appearance



## Installation Positions

The CX610 is installed in a rear slot of the E9000 chassis. **Figure 1-2** shows the positions and slots for installing the CX610s in a chassis.

**Figure 1-2** Installation positions and slots

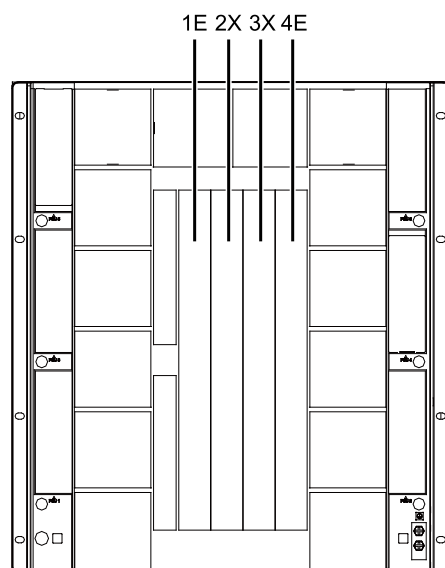

### NOTE

The CX610 panel provides more ports than other switch modules. For ease of cable routing and maintenance, you are advised to install the CX610 in slot 1E or 4E.

## Panel

**Figure 1-3** shows the CX610 panel.

**Figure 1-3 Panel**

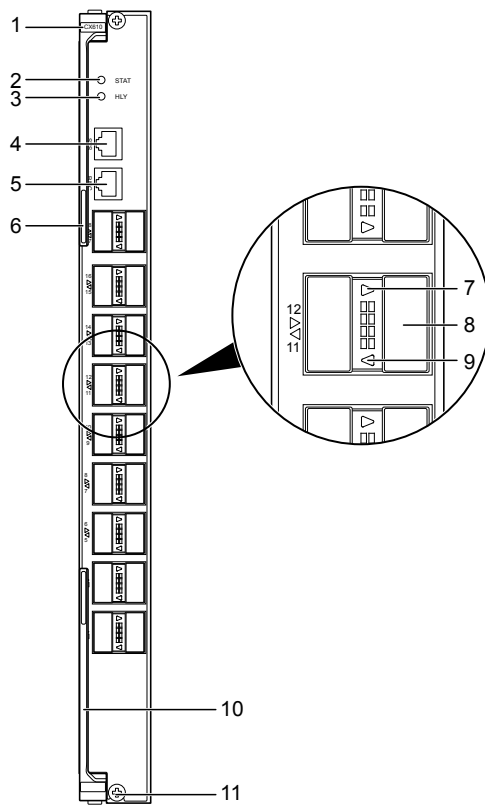

1	Product Model	2	STAT indicator
3	HLY indicator	4	SYS serial port
5	BMC serial port	6	Customization label (with an ESN label)
7	Status indicator of the right optical port	8	Optical port (QSFP+)
9	Status indicator of the left optical port	10	Ejector lever
11	Captive screw	-	-

**NOTE**

The numbers on the left side are port serial numbers. The arrow direction of a triangle indicates the direction of a port.

**ESNs**

An Equipment Serial Number (ESN) is a string that uniquely identifies a product. An ESN is required when you apply for technical support from Huawei.

**Figure 1-4** shows the ESN format.

**Figure 1-4** ESN example

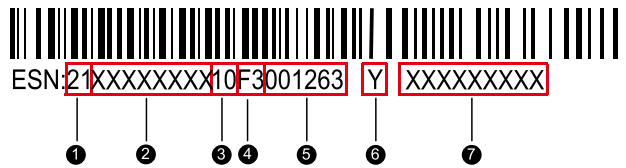

No.	Description
1	Indicates the ESN ID (two digits).
2	Indicates the item identification code (eight characters).
3	Indicates the vendor code (two characters).
4	Indicates the year and month (two characters). The first character indicates the year. The digits 1 to 9 indicate 2001 to 2009, and the letters A to Z indicate 2010 to 2035. The second character indicates the month. The digits 1 to 9 indicate January to September, and the letters A to C indicate October to December.
5	Indicates the sequence number (six digits).
6	Indicates RoHS compliance (one character).
7	Indicates the internal model number of the board.

## 1.4 Ports

This topic describes the name, type, quantity, description, and the naming rules of the ports on the CX610.

### Overview

**Table 1-1** describes the external ports on the CX610.

**Table 1-1** Ports

Port	Type	Quantity	Description
SYS serial port	RJ-45	1	The serial port is used to debug the small system and the baud rate of 115200 bit/s.
BMC serial port	RJ-45	1	The serial port is used to debug the baseboard management controller (BMC) module and the baud rate of 115200 bit/s.
Optical port	QSFP+	18	These ports are used to connect to the external network and provide FDR10 signal. One green indicator is provided for each port.

Figure 1-5 shows the CX610 port naming rules.

Figure 1-5 Port naming rules

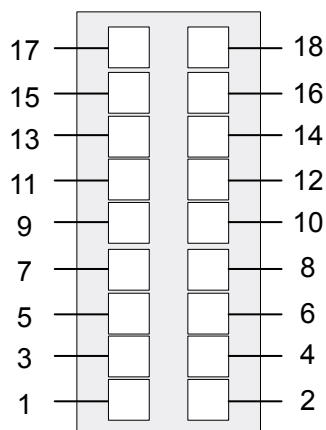

## 1.5 Indicators

This topic describes the names, meanings, colors, descriptions and working status of the indicators on the CX610.

You can observe the indicators to determine the current operating status of the CX610. [Table 1-2](#) describes the indicators.

Table 1-2 Indicators

Indicator	Meaning	Color	Description
STAT indicator	Power status indicator	Green	<ul style="list-style-type: none"> <li>● Off: The module is not powered on.</li> <li>● Blinking green: The module is being powered on.</li> <li>● Steady green: Power is properly supplied to the module.</li> </ul>

Indicator	Meaning	Color	Description
HLY indicator	Healthy indicator	Red and green	<ul style="list-style-type: none"> <li>● Off: The module is not powered on.</li> <li>● Steady green: The module is working properly.</li> <li>● Blinking red (1 Hz): A major alarm is generated.</li> <li>● Blinking red (4 Hz): A critical alarm is generated.</li> <li>● Blinking red (5 Hz): The CX610 is not installed properly.</li> </ul> <p><b>NOTE</b> It is difficult to distinguish a blinking frequency of 4 Hz from a blinking frequency of 5 Hz. When the HLY indicator is quickly blinking red, you are advised to check whether the device is securely inserted and then check whether a critical alarm is generated.</p>
Status indicator of the optical port	The status indicator of the optical port	Green	<ul style="list-style-type: none"> <li>● Off: The port is not properly connected, or the <b>opensm</b> command is not executed in the OS.</li> <li>● Steady green: The port is properly connected.</li> <li>● Blinking green: Data is being sent or received over the port.</li> </ul>

## 1.6 Internal Chassis Networking

This topic describes the networking between the CX610 and other devices in the chassis.

### Switch Chip Port Allocation

The 34 ports for the CX610 are provided by the Switch-X chip, numbered 1 to 34. The ports are allocated as follows:

- Eighteen FDR10 ports (1 to 18) on the panel connect to external devices.
- Sixteen FDR ports (19 to 34) connect to the mezzanine cards on the 16 half-width or eight full-width nodes.

**Figure 1-6** shows the allocation of the ports provided by the Switch-X chip.

**Figure 1-6** Port allocation

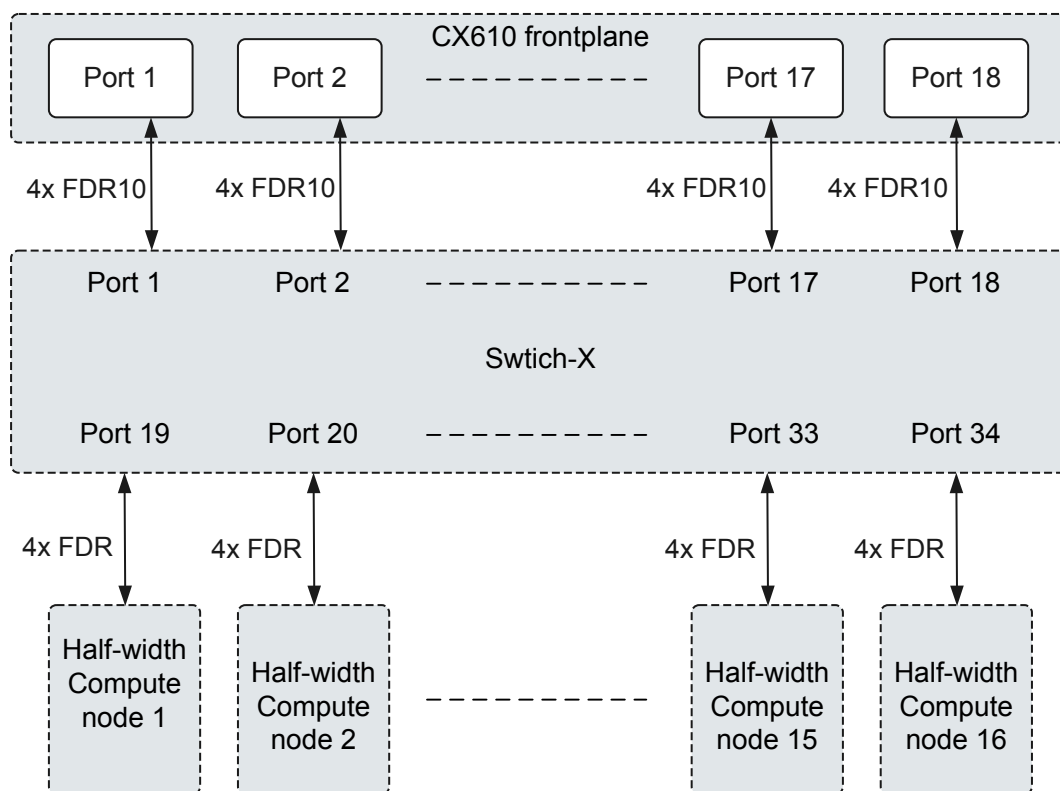

**NOTE**

The mapping between full-width nodes and ports is the same as the mapping between half-width nodes in corresponding slots and ports.

## Port mapping between switch modules and mezzanine cards

### Port mapping between the CX610s and the MZ611 mezzanine cards

The ports on mezzanine cards Mezz1 and Mezz2 of a compute node correspond to the four FDR ports of the CX610s in slots 2X, 3X, 1E, and 4E. [Figure 1-7](#) shows the port mapping between the CX610s and the MZ611 mezzanine cards.

**Figure 1-7** Port mapping between the CX610s and the MZ611 mezzanine cards

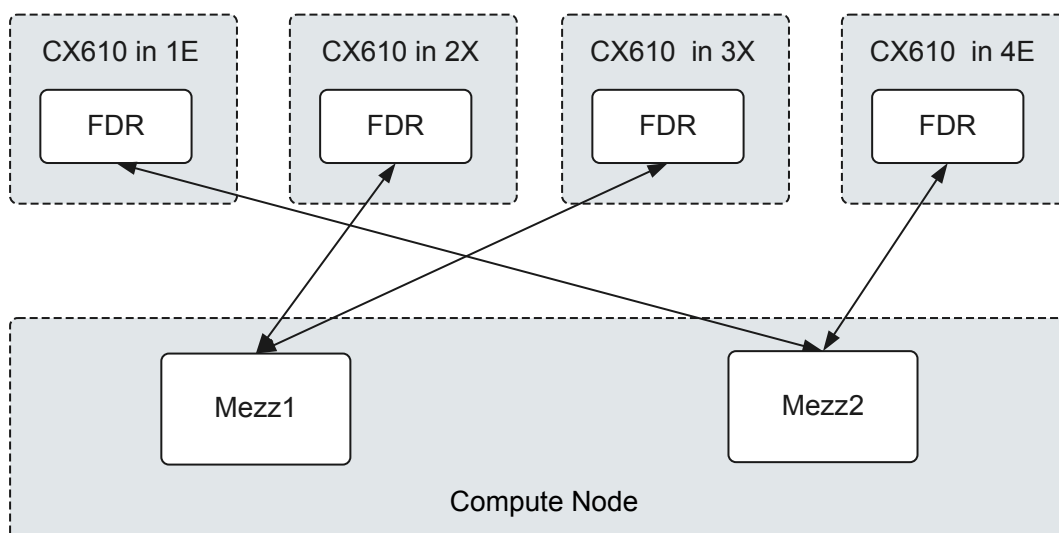

## 1.7 Software and Hardware Compatibility

This topic describes the software and hardware supported by the CX610.

For details about the software and hardware that are compatible with the CX610, see [Huawei Server Compatibility Checker](#).

### Supported Mezzanine Cards

**Table 1-3** describes the mezzanine cards supported by the CX610.

**Table 1-3** Mezzanine cards supported by the CX610

Module	Description
MZ611	2-port IB fourteen data rate (FDR) mezzanine card
MZ612	2-port IB fourteen data rate (FDR) mezzanine card

### Supported Cables and Transceivers

**Table 1-4** describes the cables and transceivers supported by the CX610.

**Table 1-4** Cables and transceivers supported by the CX610

Cable or Transceiver	Description
QSFP+ integrated optical module (FDR)	Date rate: FDR10; cable length: 3 m, 5 m, 10 m, or 20 m

Cable or Transceiver	Description
QSFP+ integrated optical module (QDR)	Date rate: QDR; cable length: 3 m, 5 m, 10 m, or 20 m
QSFP+ cable (FDR)	Date rate: FDR10; cable: 1 m or 3 m direct attached cable (DAC)
Console cable	Supports an RJ45 port and serves as the connection cable for an RS232 serial port

The CX610 supports various pluggable optical modules and DACs. You can choose optical modules and DACs based on site requirements.

- The CX610 provides the following functions for FDR10 applications:
  - Provides QSFP+ optical ports and supports IB-dedicated FDR optical modules and DACs.
  - Supports 1 m or 3 m QSFP+ DACs for connections.
- The CX610 provides the following functions for QDR applications:
  - Provides QSFP+ optical ports and supports IB-dedicated QDR optical modules and DACs.
  - Supports 1 m or 3 m QSFP+ DACs for connections.

## 1.8 Technical Specifications

This topic describes the physical, environmental, and power specifications of the CX610.

**Table 1-5** describes the CX610 technical specifications.

**Table 1-5** Technical Specifications

Category	Item	Specifications
Physical specifications	Dimensions (H x W x D)	388.55 mm x 35.06 mm x 272.15 mm (15.30 in. x 1.38 in. x 10.71 in.)
	Color	Silver white
	Weight	3.6 kg
Environmental specifications	Temperature	<ul style="list-style-type: none"> <li>● Operating temperature: 5°C to 40°C (41°F to 104°F) (ASHRAE Class A3 compliant)</li> <li>● Storage temperature: -40°C to +65°C (-40°F to +149°F)</li> <li>● Long-term storage temperature: 21°C to 27°C (69.8°F to 80.6°F)</li> </ul>
	Temperature change rate	15°C/h (27°F/h)



Category	Item	Specifications
	Humidity	<ul style="list-style-type: none"> <li>● Operating humidity: 5% RH to 85% RH (non-condensing)</li> <li>● Storage humidity: 5% RH to 95% RH (non-condensing)</li> <li>● Long-term storage humidity: 30% RH to 69% RH (non-condensing)</li> </ul>
	Altitude	<p>At an altitude of 900 m (2952.72 ft), the highest operating temperature is 40°C (104°F).</p> <p>When the device is used at an altitude of 900 m to 5000 m, the highest operating temperature decreases by 1°C (1.8°F) as the altitude increases by 300 m (984.24 ft).</p>
Input power supply	Rated input voltage	12 V DC
Power consumption	Maximum power consumption	144 W

# 2 Standards and Certifications

---

## About This Chapter

### [2.1 Standards Compliance](#)

This topic describes the international and industrial standards and communication protocols that the CX610 complies with.

### [2.2 Certifications](#)

This topic describes the certifications that the E9000 has passed.

## 2.1 Standards Compliance

This topic describes the international and industrial standards and communication protocols that the CX610 complies with.

### International Standards

**Table 2-1** lists the international standards.

**Table 2-1** Standards and protocol compliance

Standard	Protocol
IBTA1.21	IB Trade Association 1.21

### Industrial Standards

**Table 2-2** lists the industrial standards.

**Table 2-2** Industrial standards

Organization	Standard
ECMA TR/70	Environment protection
EN60950	Safety (Europe)
GR-929	Reliability
IEC60297	Chassis compliance
IEC60950	Safety
IEC60825-1/2/6	Safety
IEC60215	Safety
IEC61000	EMC standard
IEC 863	Reliability, maintainability, and availability compliance standard
Telcordia SR-332	Reliability
UL60950	Safety (North America)

### Communication Protocols

**Table 2-3** lists the communication protocols.

**Table 2-3** Communication protocols

Protocol	Description
ARP	Address Resolution Protocol
FTP	File Transfer Protocol
HTTP	Hypertext Transfer Protocol
ICMP	Internet Control Message Protocol
IP	Internet Protocol
IPMI	Intelligent Platform Management Interface
NTP	Network Time Protocol
SNMP	Simple Network Management Protocol
SSH	Secure Shell
SSL	Secure Socket Layer
TCP	Transmission Control Protocol
TELNET	Remote terminal protocol
TFTP	Trivial File Transfer Protocol
UDP	User Datagram Protocol

## 2.2 Certifications

This topic describes the certifications that the E9000 has passed.

**Table 2-4** lists the certifications.

**Table 2-4** Certifications

Country /Region	Certification	Standard
Europe	WEEE	2002/96/EC, 2012/19/EU
Europe	RoHS	2002/95/EC, 2011/65/EU, EN 50581: 2012
Europe	REACH	EC NO. 1907/2006

Country /Region	Certification	Standard
Europe	CE	Safety: EN 60950-1: 2006+A11: 2009+A1: 2010+A12: 2011 EMC: <ul style="list-style-type: none"> <li>● EN 55022: 2010</li> <li>● CISPR 22: 2008</li> <li>● EN 55024: 2010</li> <li>● CISPR 24: 2010</li> <li>● ETSI EN 300 386 V1.6.1: 2012</li> <li>● ETSI ES 201 468 V1.3.1: 2005</li> </ul>
China	RoHS	SJ/T-11363-20006 SJ/T-11364-20006 GB/T 26572-2011
China	China Environmental Labeling	GB/T24024: 2001 idt ISO14024: 1999 HJ 2507-2011
Australia	C-tick	AS/NZS CISPR22: 2009
America	UL	UL 60950-1
America	FCC	FCC Part 15 (Class A)
America	NTRL-UL	UL 60950-1, 2nd Edition, 2011-12-19 (Information Technology Equipment - Safety - Part 1: General Requirements) CSA C22.2 No.60950-1-07, 2nd Edition, 2011-12 (Information Technology Equipment-Safety-Part 1: General Requirements)
Canada	IC	ICES-003 Class A
Nigeria	SONCAP	IEC 60950-1: 2005 (2nd Edition) + A1: 2009 EN 60950-1: 2006+A11: 2009+A1: 2010 + A12: 2011
Kingdom of Saudi Arabia (KSA)	SASO	IEC 60950-1: 2005 (2nd Edition) + A1: 2009 EN 60950-1: 2006+A11: 2009+A1: 2010 + A12: 2011
Global	CB	IEC 60950-1
Japan	VCCI	VCCI V-4: 2012