



**OceanStor 18000F V5 Series
V500R007**

Product Description

Issue **02**
Date **2018-01-30**

Copyright © Huawei Technologies Co., Ltd. 2018. All rights reserved.

No part of this document may be reproduced or transmitted in any form or by any means without prior written consent of Huawei Technologies Co., Ltd.

Trademarks and Permissions



HUAWEI and other Huawei trademarks are trademarks of Huawei Technologies Co., Ltd.

All other trademarks and trade names mentioned in this document are the property of their respective holders.

Notice

The purchased products, services and features are stipulated by the contract made between Huawei and the customer. All or part of the products, services and features described in this document may not be within the purchase scope or the usage scope. Unless otherwise specified in the contract, all statements, information, and recommendations in this document are provided "AS IS" without warranties, guarantees or representations of any kind, either express or implied.

The information in this document is subject to change without notice. Every effort has been made in the preparation of this document to ensure accuracy of the contents, but all statements, information, and recommendations in this document do not constitute a warranty of any kind, express or implied.

Huawei Technologies Co., Ltd.

Address: Huawei Industrial Base
Bantian, Longgang
Shenzhen 518129
People's Republic of China

Website: <http://e.huawei.com>

About This Document

Purpose

This document describes the orientation, features, architecture, technical specifications, product configuration, environment requirements, standard compliance and granted certifications of the OceanStor storage system.

Supported product models are as follows.



Product Series	Product Model
OceanStor 18000F V5 series	OceanStor 18500F V5 and 18800F V5



Intended Audience

This document is intended for: All readers

Symbol Conventions

The symbols that may be found in this document are defined as follows.

Symbol	Description
 DANGER	Indicates an imminently hazardous situation which, if not avoided, will result in death or serious injury.
 WARNING	Indicates a potentially hazardous situation which, if not avoided, could result in death or serious injury.
 CAUTION	Indicates a potentially hazardous situation which, if not avoided, may result in minor or moderate injury.

Symbol	Description
 NOTICE	Indicates a potentially hazardous situation which, if not avoided, could result in equipment damage, data loss, performance deterioration, or unanticipated results. NOTICE is used to address practices not related to personal injury.
 NOTE	Calls attention to important information, best practices and tips. NOTE is used to address information not related to personal injury, equipment damage, and environment deterioration.

Change History

Changes between document issues are cumulative. The latest document issue contains all the changes made in earlier issues.

Issue 02 (2018-01-30)

This issue is the second official release.

Made some changes in specifications.

Issue 01 (2017-11-30)

This issue is the first official release.

Contents

About This Document.....	ii
1 Product Positioning.....	1
2 Product Features.....	4
3 Typical Applications.....	8
4 Hardware Architecture.....	13
4.1 Engines.....	15
4.1.1 Overview.....	15
4.1.2 Component Description.....	19
4.1.3 Indicator Introduction.....	38
4.2 U Disk Enclosure (2.5-Inch Disks).....	41
4.2.1 Overview.....	42
4.2.2 Component Description.....	43
4.2.2.1 System Subrack.....	43
4.2.2.2 Expansion Module.....	44
4.2.2.3 Power Module.....	45
4.2.2.4 Disk Module.....	46
4.2.3 Indicator Introduction.....	47
4.3 Coffered Disk.....	49
4.4 Data Switch.....	51
4.5 SVP.....	53
4.6 (Optional) Quorum Server.....	56
4.7 Device Cables.....	61
4.7.1 Power Cable.....	61
4.7.2 Ground Cable.....	62
4.7.3 Network Cable.....	62
4.7.4 Serial Cable.....	63
4.7.5 Mini SAS HD Cables.....	63
4.7.5.1 Mini SAS HD Electrical Cables.....	64
4.7.5.2 Mini SAS HD Optical Cables.....	64
4.7.6 Optical Fiber.....	65
4.7.7 AOC Cable.....	65
4.7.8 FDR Cables.....	66

4.7.9 MPO-4*DLC Fiber.....	66
5 Software Architecture.....	68
6 Product Specifications.....	76
6.1 Hardware Specifications.....	76
6.2 Software Specifications.....	82
7 Environmental Requirements.....	93
7.1 Temperature and Humidity.....	93
7.2 Vibration and Shock.....	94
7.3 Particle Contaminants.....	95
7.4 Corrosive Airborne Contaminants.....	96
7.5 Heat Dissipation and Noise.....	98
8 Standards Compliance.....	100
9 Certifications.....	105
10 Operation and Maintenance.....	108
A How to Obtain Help.....	110
A.1 Preparations for Contacting Huawei.....	110
A.1.1 Collecting Troubleshooting Information.....	110
A.1.2 Making Debugging Preparations.....	111
A.2 How to Use the Document.....	111
A.3 How to Obtain Help from Website.....	111
A.4 Ways to Contact Huawei.....	111
B Glossary.....	112
C Acronyms and Abbreviations.....	113

1 Product Positioning

The OceanStor 18000F V5 series (OceanStor 18500F V5 and 18800F V5 mission critical storage system) is Huawei's next-generation of enterprise products feature virtualization, hybrid cloud, thin IT, and low carbon footprint. The storage system offers an advanced storage solution for mission-critical services in medium- and large-sized enterprise data centers, virtualization data centers, and cloud data centers. It provides fast data access, high availability, and high utilization in the ease-of-use and energy saving form factor.

The series inherits the flexible and scalable design and adopts the innovative SmartMatrix 2.0 architecture. The architecture has a horizontal expansion system of multiple engines (each engine containing up to four controllers) and provides up to four system bays and twenty disk bays for enterprise data centers. The hardware is seamlessly integrated into enterprise data centers, boosting their efficiency and scalability for a wide range of environments such as Online Transaction Processing/Online Analytical Processing (OLTP/OLAP), high-performance computing (HPC), digital media, Internet-based operation, centralized storage, backup, disaster recovery, and data migration.

Figure 1-1 shows the appearance of the OceanStor 18500F V5 and 18800F V5 mission critical storage system.

Figure 1-1 OceanStor 18500F V5 and 18800F V5 mission critical storage system

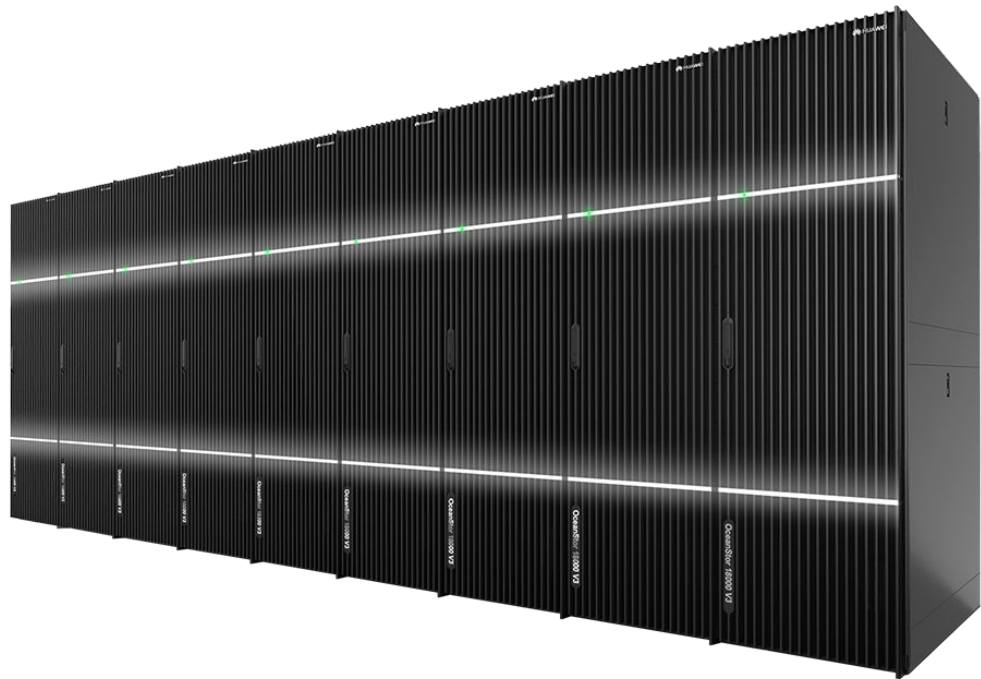

The OceanStor 18000F V5 series provides high-performance storage services for data centers. Various complete data backup and disaster recovery schemes are available to ensure smooth and secure service operation. In addition, the series offers easy-to-use management modes and convenient local/remote maintenance modes, greatly reducing the management and maintenance costs. [Figure 1-2](#) shows its role and applications in the network.

Figure 1-2 Role and applications of OceanStor 18500F V5 and 18800F V5 mission critical storage system in the network

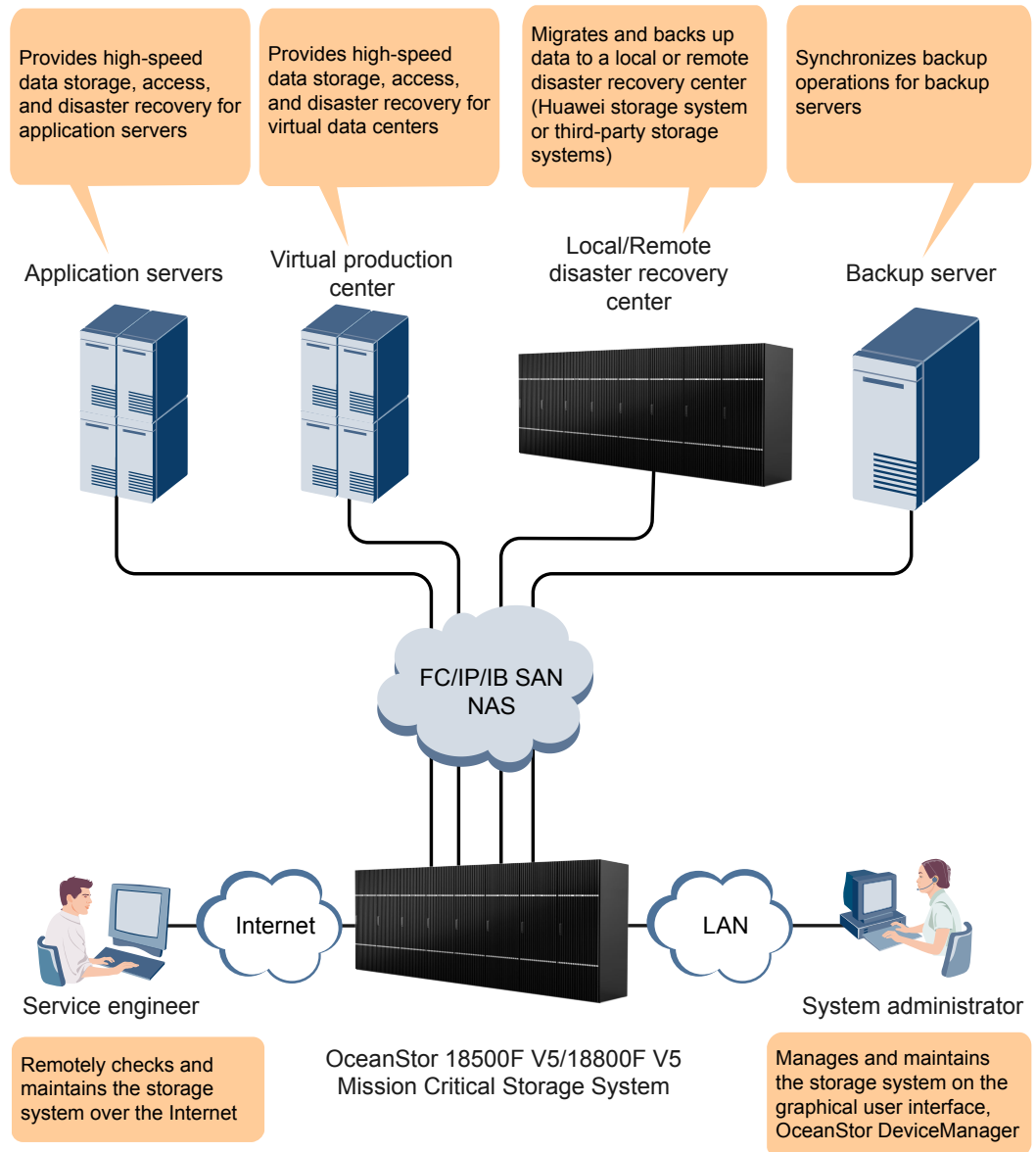

2 Product Features

The OceanStor 18000F V5 series employs high-grade hardware, innovative SmartMatrix 2.0 architecture, virtualized intelligent volumes, and multiple resource management and data protection technologies, committed to providing secure, trusted, flexible, and efficient core storage solutions for enterprise-class data centers.

Trusted, Ensuring 24/7 Availability for Core Services

The OceanStor 18000F V5 series adopts SmartMatrix 2.0 architecture that provides full switching, full virtualization, full redundancy, and inherent load balance. The architecture integrates with advanced data protection technologies such as end-to-end data integrity, memory error checking and correcting (ECC), and transmission channel cyclic redundancy check (CRC) to boost mission-critical services of medium- and large-sized data centers. The advanced hardware and various data protection technologies enable linear storage performance growth, 24/7 storage service, and high system security.

- **Innovative SmartMatrix 2.0 architecture**
A full-switching hardware architecture with the mission critical storage-dedicated OceanStor OS operating system meets most stringent reliability, performance and capacity requirements.
- **Full redundancy**
Intelligent redundancy technology is implemented for all hardware components in the storage system, ensuring service continuity in harsh scenarios.
- **RAID 2.0+ technology**
RAID 2.0+ technology achieves load balance across disks, and accelerates data recovery by 20 times.
- **Intelligent protection dedicated to core services**
The SmartQoS and SmartPartition features provide advanced protection for core services.
- **Complete disaster recovery solution**
The Hyper series management software suite provides a complete data protection strategy and disaster recovery solution.
- **Data protection in the event of a controller failure**
 - Built-in backup battery units (BBUs) supply power to controller enclosures in the event of unexpected power failures. BBUs enable cache data to be written to built-in disks of controllers to avoid data loss.

- When a piece of software is faulty, the storage system will attempt to reboot. During the reboot, data is stored in the cache. If the reboot fails, data in the cache will be written into the built-in disks of controllers to avoid data loss.
- If hardware of a controller is faulty, the storage system will use the memory mirroring technology to enable the other normal controller to take over the services to ensure data consistency.
- Online disk diagnosis
The online disk diagnosis feature is used to handle disk faults. If a disk fault occurs, the storage system takes the disk offline. Then, the online diagnosis module reads the S.M.A.R.T information about the disk and takes analysis, testing, and recovery measures. After the disk is recovered, the online diagnosis module enables the disk to rejoin the RAID, prolonging the lifecycle of the disk.
- Data coffer disk
Data coffer disks consist of the first four disks of a storage system's disk enclosure as well as each controller's built-in disks. They stores three types of data: cache data requiring power failure protection, OceanStor OS system data, and system configuration information and logs.
- Hot-swappable components
Controllers, fans, power supplies, interface modules, BBUs, and disk modules are hot swappable and can be operated online.
- Quick document incremental backup with Tivoli Storage Manager (TSM)
When the storage system interworks with the TSM backup software to perform incremental file backup, the Snapdiff feature uses the snapshot mechanism to quickly obtain differential file information and identify changed files. Without the need for full scanning, only changed files are backed, greatly shortening backup time. The backup performance is not affected by the number of files, which greatly improves the backup efficiency.

High System Security

Storage network security:

- Security of management channels
Management operations from physical ports are controlled by a storage system's access authentication mechanism, and only authorized users are allowed to manage the storage system.
- Anti-attack protection for protocols and ports
The storage system provides only necessary ports to the external for system operations and maintenance. All the ports used are listed in the *Communication Matrix*. Dynamic listening ports are functioning in the proper scope, and no unopened port exists.
- Isolation between service ports and management ports
The Access Control List (ACL) mechanism is adopted to isolate Ethernet ports from internal heartbeat network ports, management network ports, and maintenance network ports.

Storage service security:

- Security of the operating system
The storage system uses a dedicated operating system. Its security has been hardened prior to delivery. The storage system updates security patches for its operating systems and open-source software based on site requirements, thereby safeguarding users' data.

- Encrypted data transfer
Virtual private network (VPN) devices are used to establish an internet small computer system interface (iSCSI) transfer channel between two storage devices. Data transferred between storage devices is encrypted to ensure privacy and security. Encrypted data transfer can apply to service data transfer in using value-added features, such as LUN copy, synchronous remote replication, and asynchronous remote replication.
- Data storage encryption
 - The storage system supports data encryption by using a network password manager. The network password manager employs the standard cryptographic algorithm supported by the State Encryption Administration of China. It allows only the hosts that comply with security policies to access storage system data by auditing access control policies and controlling access attempts from hosts. After the network password manager is deployed, all mutual information between the hosts and storage system will pass the network password manager to enable read/write data encryption and decryption and ensure data security of the storage system.
 - The storage system supports disk encryption. The hardware circuits and internal data encrypt key of disks are used for data writing encryption and data reading decryption. To ensure the security of the data encrypt key, the storage system and the third-party key management server jointly provide a highly secure, reliable, and available key management solution.
- Data destruction
When deleting unwanted data, the system erases the specified LUN to ensure that the deleted data cannot be restored, preventing critical data leaks.
- File antivirus
When the storage system runs a file system and shares the file system with clients through CIFS, third-party antivirus software can be used to trigger virus scanning and delete virus-infected files, improving storage system security.

Storage management security:

- Security of management and maintenance
The operations of users can be allowed and denied. All management operations are logged by the system.
- Data integrity protection and tamper resistance
The Write Once Read Many (WORM) feature allows users to set critical data to read-only state, preventing unauthorized data change and deletion during a specified period of time.

In addition, trusted verification is enabled during the storage system startup to measure and verify **BIOS > Grub > Euler Linux Kernel > Euler Linux > Storage application software** level by level to prove integrity of loaded software at each level and to prevent software tampering. The storage system's power-on process will be verified to ensure that the system is not tampered with.

Flexible, Meeting Future Challenges

- The OceanStor 18000F V5 series possesses a comprehensive 4S scalability: scale-up, scale-out, scale-deep, and scale-in. The 4S scalability dynamically improves system performance and capacity to meet the increasing services.
 - Scale-up
Increases the storage capacity and performance of controllers.

- Scale-out
Enables linear performance increase with the storage space.
- Scale-deep
Implements consolidation with third-party storage devices.
- Scale-in
Fully explores the potentials of a storage system to improve the performance and storage capacity of host volumes without adding any hardware resources and let the storage system be infinitely adapted to service needs.
- The OceanStor 18000F V5 series employs an intelligent three-dimensional (3D) data flow technology. That is, data intelligently flows vertically, horizontally, and among devices. This technology enables all-directional data flow, boosting overall disk resource utilization by times, and maximizing ROI for customers.
 - Intelligent horizontal data flow
The SmartMotion feature automatically balances data distribution within disks in the same storage tier to avoid system bottlenecks caused by hotspot disks, improving disk utilization and the overall disk reliability.
 - Intelligent data flow among devices
The SmartVirtualization feature simplifies the storage system management, improves the resource usage, and maximizes customers' return on investment (ROI) by integrating the resources on heterogeneous storage arrays and providing unified storage to application servers.
- The OceanStor 18000F V5 series easily adapts to virtualization trends. The fully virtualized software architecture with wide support for open standards improves the working efficiency, data protection, and management capability in virtual environments.
- The OceanStor 18000F V5 series employs data reduction technology to find and process redundant data on disks, which improves disk utilization efficiently.
- The OceanStor 18000F V5 series employs multiple resource application technologies and provides flexible resource management to protect customers' storage investments. The resource application technologies include SmartVirtualization, SmartMigration, and SmartMulti-Tenant.
 - SmartVirtualization enables a local storage system to centrally manage storage resources of third-party storage systems, simplifying storage system management and reducing maintenance costs.
 - SmartMigration migrates LUNs in or between storage systems, adjusting and allocating resources along with business development.
 - SmartMulti-Tenant enables a storage system to provide different tenants with shared storage resources and to separate tenant access and management.
- The OceanStor 18000F V5 series provides flexible management approaches such as using tablets for management.
- Cloud-based operation and maintenance (Call Home service)
Huawei provides the Call Home service to remotely connect OceanStor 18000F V5 series storage system to the eService cloud platform, enabling centralized, remote, and intelligent operation and maintenance of storage devices. The Big Data analytics technology is used to prevent faults and locate faults quickly. In addition, it provides the optimal configuration, performance optimization suggestions, and troubleshooting solutions based on user service characteristics.

3 Typical Applications

As a high-end storage system designed for medium- and large-sized enterprise data centers, the OceanStor 18000F V5 series provides data storage for mission-critical services, virtual environments, mixed services, and three-data center disaster recovery solutions.

Mission-Critical Services

The OceanStor 18000F V5 series boasts the innovative SmartMatrix 2.0 architecture, industry-leading hardware specifications, and 100% component redundancy. It provides large capacity, high performance, and 24/7 data storage operation for mission-critical services such as enterprise resource planning (ERP), customer relationship management (CRM), business and operation support system (BOSS), office automation (OA), online transaction, electrical dispatch, tax management, and credit systems.

Figure 3-1 illustrates how the OceanStor 18000F V5 series data for mission-critical services.

Figure 3-1 Storage for mission-critical services

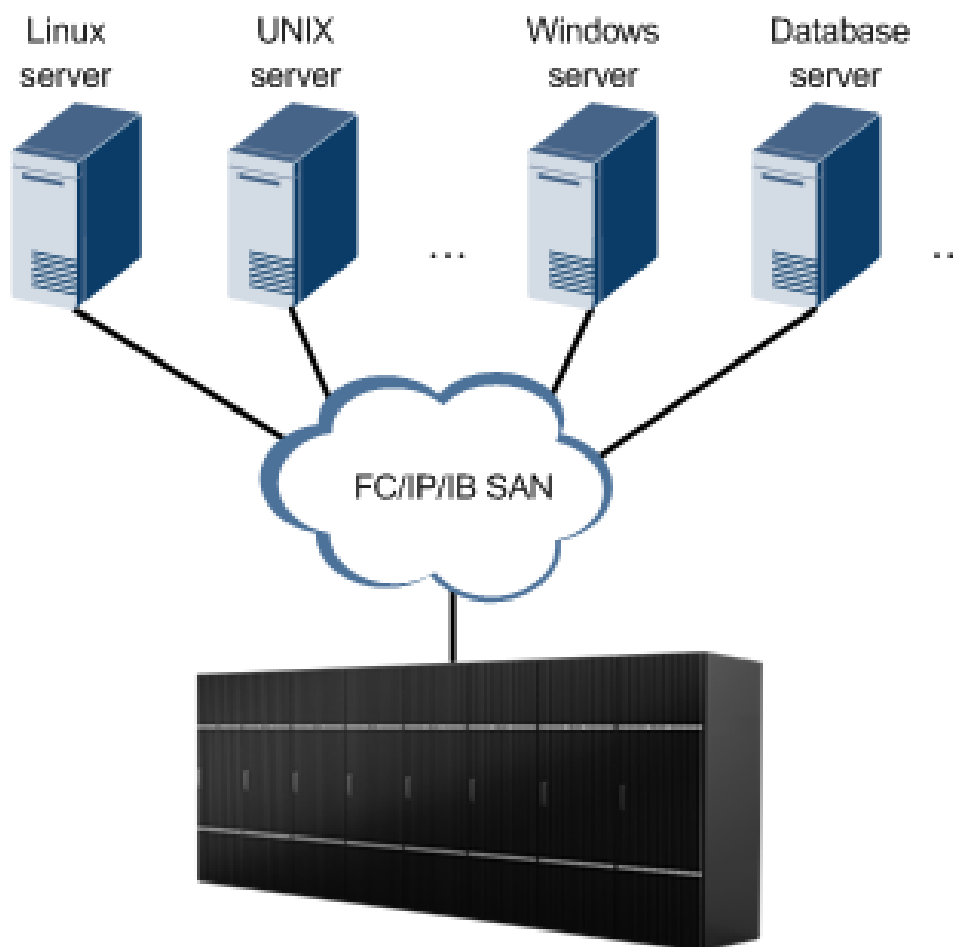

Virtual Environments

The OceanStor 18000F V5 series offers powerful compatibility to lower the total cost of ownership (TCO) and maximize the return on investment (ROI) of enterprises. It incorporates server virtualization optimization technologies such as vStorage APIs for Array Integration (VAAI), vStorage APIs for Storage Awareness (VASA) and Site Recovery Manager (SRM). It also employs numerous key technologies to enhance the deployment efficiency, bearing capacity, and operating efficiency of virtual machines (VMs) and simplify storage management in virtual environments, helping you easily manage with storage in a virtual environment.

Figure 3-2 illustrates how the OceanStor 18000F series stores data in a virtual environment.

Figure 3-2 Storage in a virtual environment

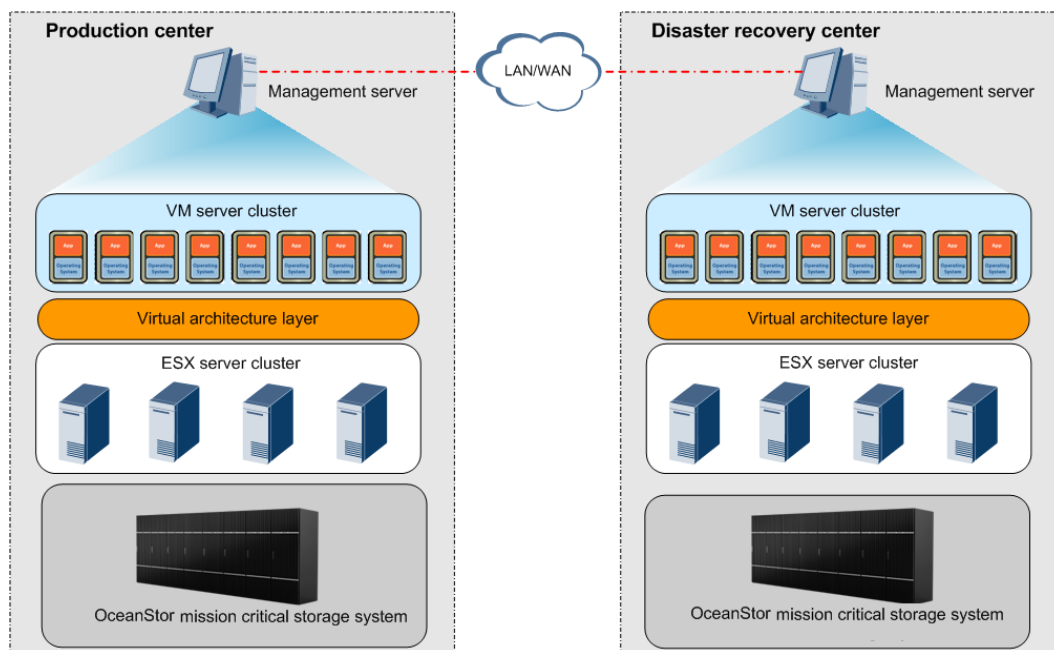

Mixed Services

It is difficult for a storage system processing large amounts of mixed services to predict data growth, control service response time, separate data and cold data, and reduce storage resource waste. The OceanStor 18000F V5 series, with its smart, flexible, and efficient design concept, serves as an effective solution to these problems.

Figure 3-3 illustrates how the OceanStor 18000F V5 series storage stores data for mixed services.

Figure 3-3 Storage for mixed services

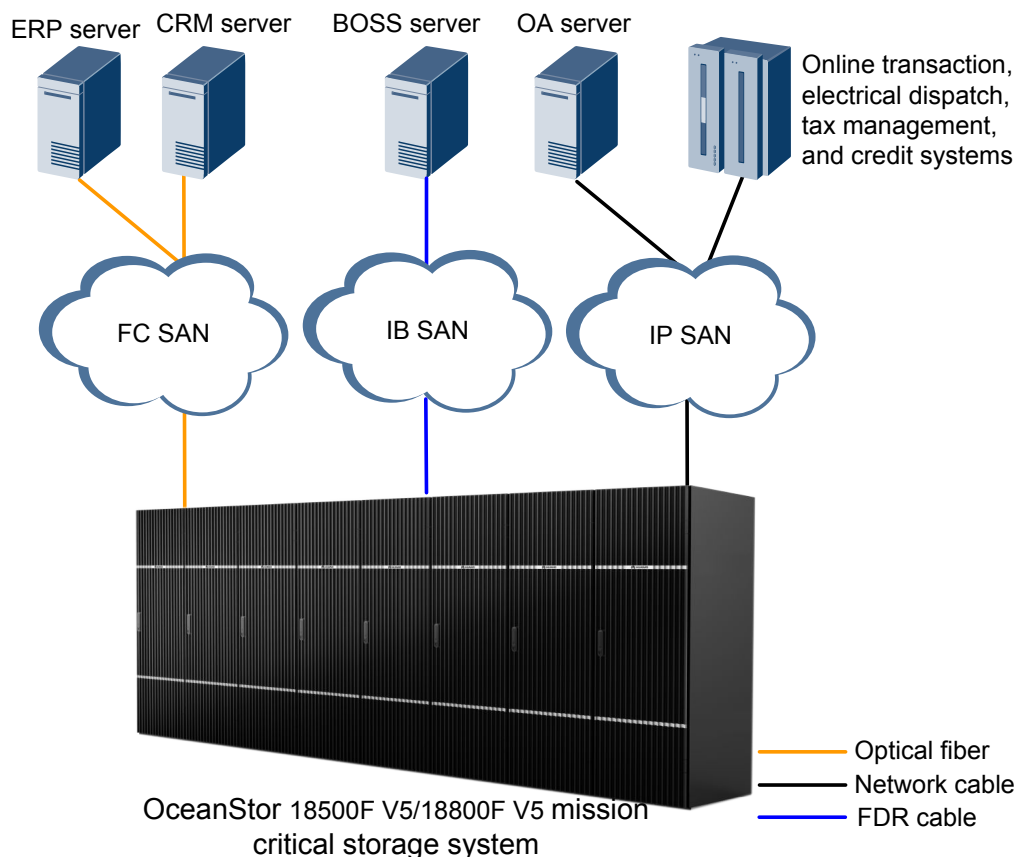

Three-Data Center Disaster Recovery

The OceanStor 18000F V5 series provides a wide range of data protection technologies, including snapshot, remote replication, LUN copy, and cloning. Among these technologies, remote replication can be used in three-data center disaster recovery solutions that have demanding requirements for recovery time object (RTO) and recovery point object (RPO).

Figure 3-4 illustrates the disaster recovery of critical data in the three-data center topology.

Figure 3-4 Three-data center disaster recovery solution

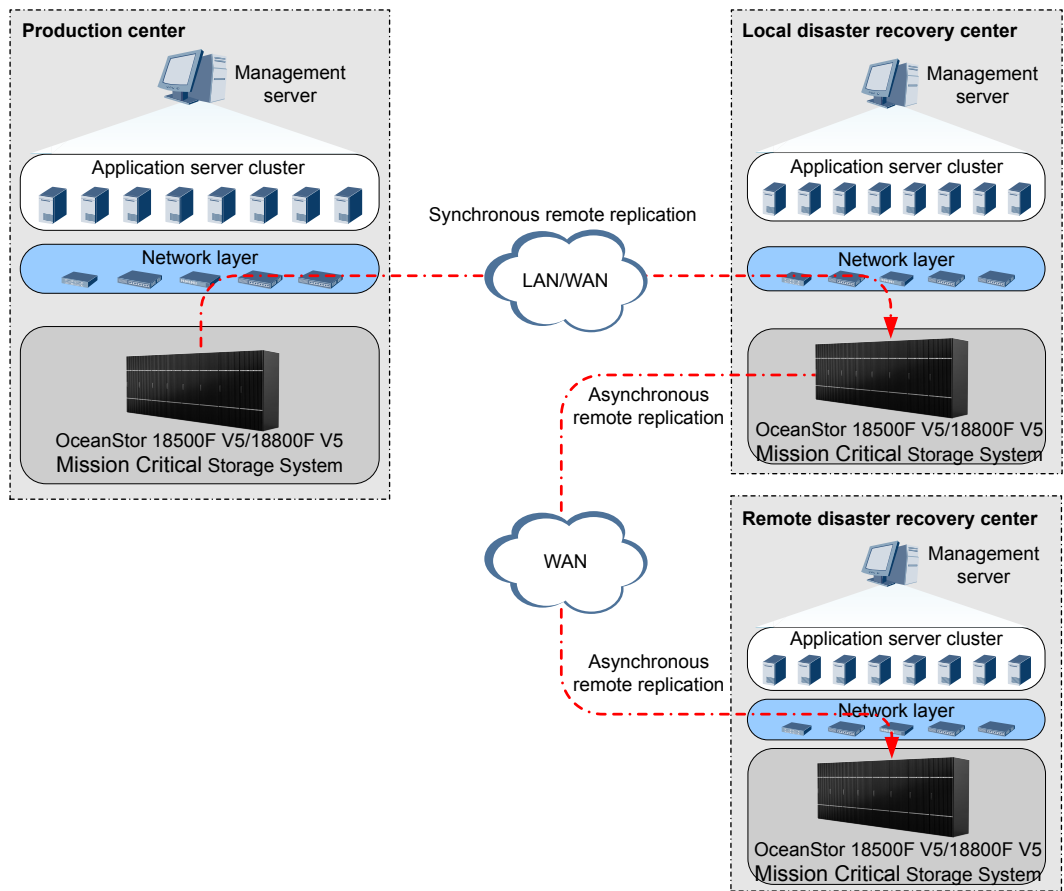

4 Hardware Architecture

About This Chapter

The OceanStor 18500F V5/18800F V5 mission critical storage system is Huawei storage product designed for medium- and large-sized enterprise data centers. It consists of system bays and disk bays. In AC scenario, a system bay consists of an engine, disk enclosures, a keyboard, video, and monitor (KVM), a service processor (SVP), and data switches. Each disk bay houses disk enclosures.

AC Scenario

The OceanStor 18500F V5/18800F V5 supports up to four system bays as system bay 0, system bay 1, system bay 2, system bay 3 and twelve disk bays.

- System bay 0 houses disk enclosures (up to sixteen 2 U disk enclosures), an SVP, a KVM, and an engine.
- System bay 1 houses disk enclosures (up to sixteen 2 U disk enclosures), two data switches, and an engine.
- System bay 2 or system bay 3 houses disk enclosures (up to sixteen 2 U disk enclosures) and an engine.

Figure 4-1 shows the front view of system bays and disk bays.

Figure 4-1 Front view of system bay 0 and disk bays

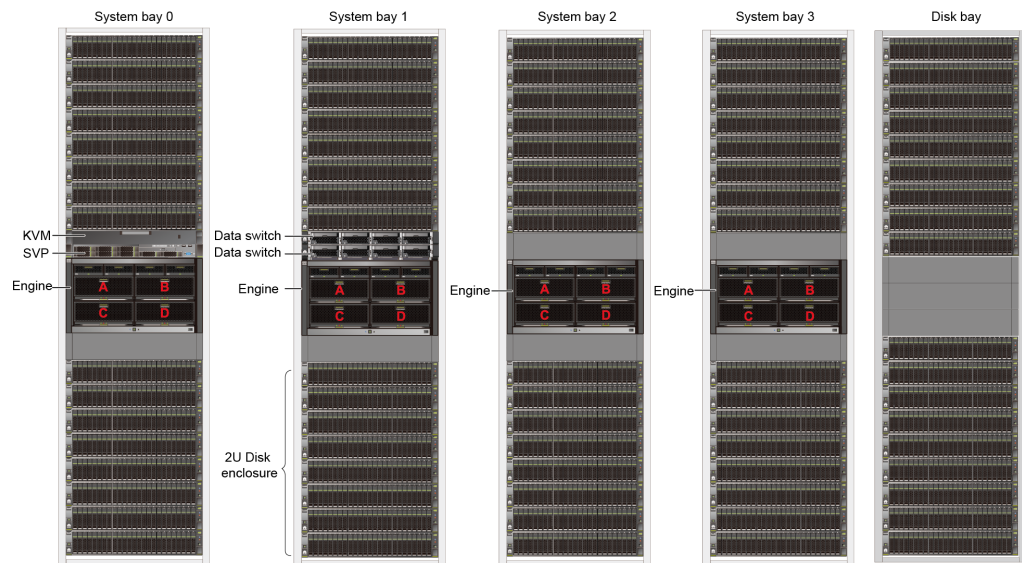

4.1 Engines

Engines are the core components of system bays. The engine consists of a system subrack, controller modules, BBU modules, fan modules, power modules, and host interface modules (multiple types allowed).

4.2 2 U Disk Enclosure (2.5-Inch Disks)

This section describes a disk enclosure in terms of its hardware structure, component functions, front and rear views, and indicators.

4.3 Coffer Disk

The storage system has two kinds of coffer disks: built-in coffer disk and external coffer disk. Coffers are used to store three types of data: cache data requiring power failure protection, OceanStor OS system data, and system configuration information and logs.

4.4 Data Switch

With high bandwidth and low latency, data switches are the key to interconnection and communication among engines as well as control data flow and service flow exchange among controllers.

4.5 SVP

When the bay uses AC power, the service processor (SVP), working with the keyboard, video, and mouse (KVM), is the core component for managing, configuring, and maintaining the OceanStor 18500F V5/18800F V5 mission critical storage system. Maintenance and management tools are installed on the SVP and used for local or remote monitoring, management, configuration, and authentication.

4.6 (Optional) Quorum Server

For HyperMetro, if the heartbeats between two storage arrays are interrupted, the quorum server decides which storage array continues providing services, thereby greatly improving host service continuity.

4.7 Device Cables

Device cables used in the storage system include power cables, ground cables, and signal cables. This section shows these cables and describes their functions and specifications.

4.1 Engines

Engines are the core components of system bays. The engine consists of a system subrack, controller modules, BBU modules, fan modules, power modules, and host interface modules (multiple types allowed).

4.1.1 Overview

Each engine has two or four controllers that have advanced CPUs, memories, host ports, and expansion ports.

Overall Structure

Figure 4-2 shows the overall structure of an engine.

Figure 4-2 Overall structure of an engine

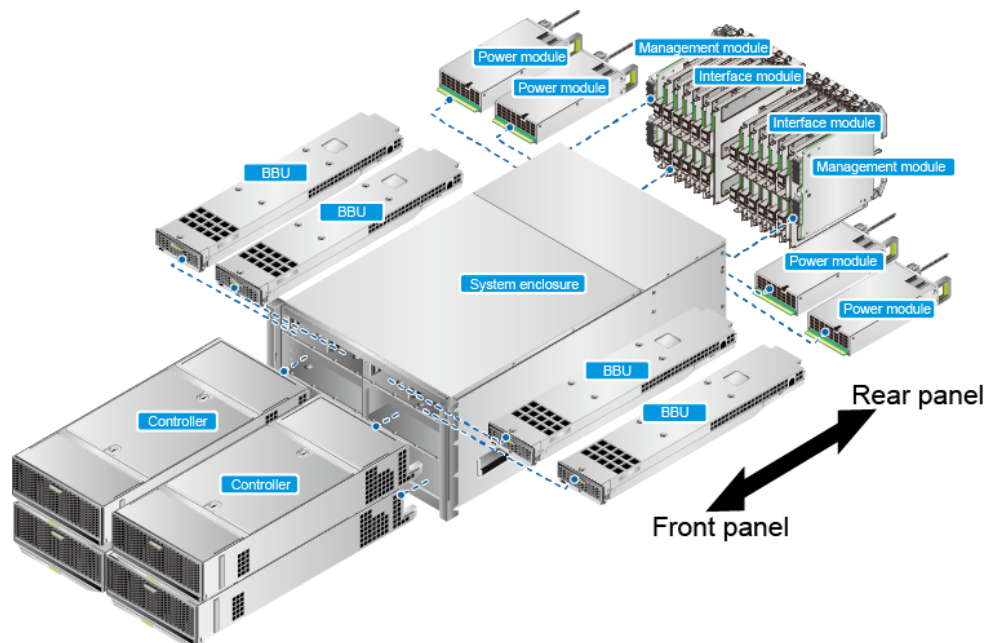

NOTE

- When two controllers are deployed in an engine, both controllers are inserted into the upper slots and assistant cooling units are inserted into the lower slots.
- Slots accommodate and secure disks, interface modules, controller modules, fan modules, and power modules.

Front View

Figure 4-3 shows the front view of an engine.

Figure 4-3 Front view of an engine

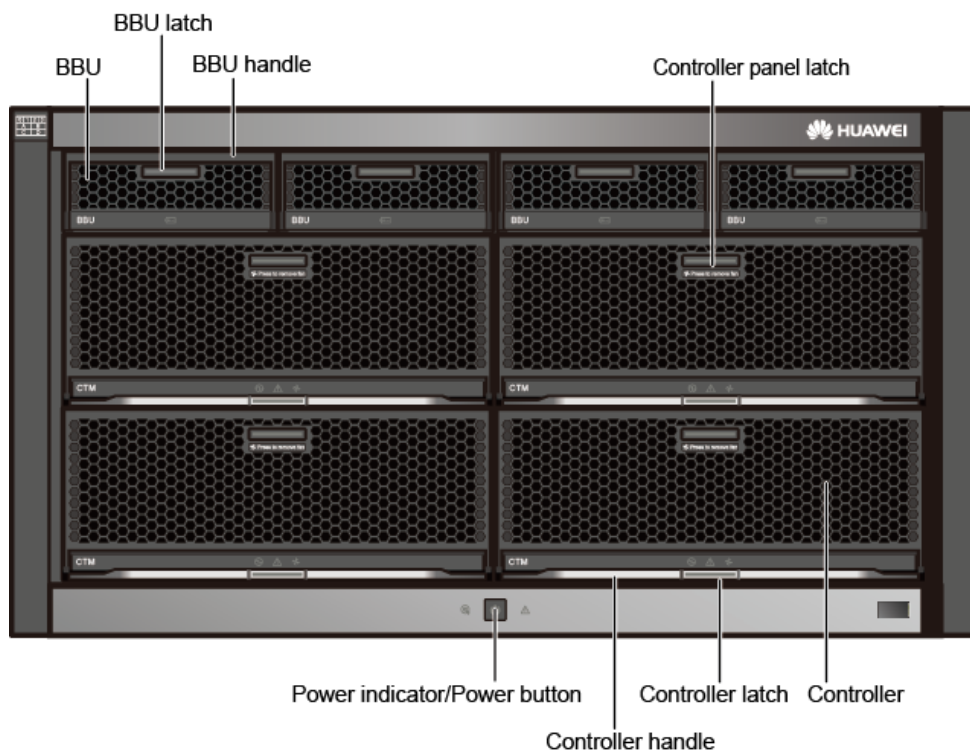

NOTE

After opening the controller panel latch, you will see that each controller contains three fan modules.

Rear View

Figure 4-4 shows the rear view of an engine with the AC power module.

NOTE

An engine supports 8 Gbit/s Fibre Channel interface modules (four ports), GE electrical interface modules, 10GE electrical interface modules, 10 Gbit/s FCoE interface modules (two ports), 56 Gbit/s IB interface modules, SmartIO interface modules, 8 Gbit/s Fibre Channel interface modules (eight ports), 16Gbit/s Fibre Channel interface modules (eight ports) (applicable to OceanStor 18500F V5), 12 Gbit/s SAS shared expansion modules and PCIe interface modules.

NOTICE

Do not connect the management network port and maintenance network port to the same switch.

Figure 4-4 Rear view of an engine with the AC power module

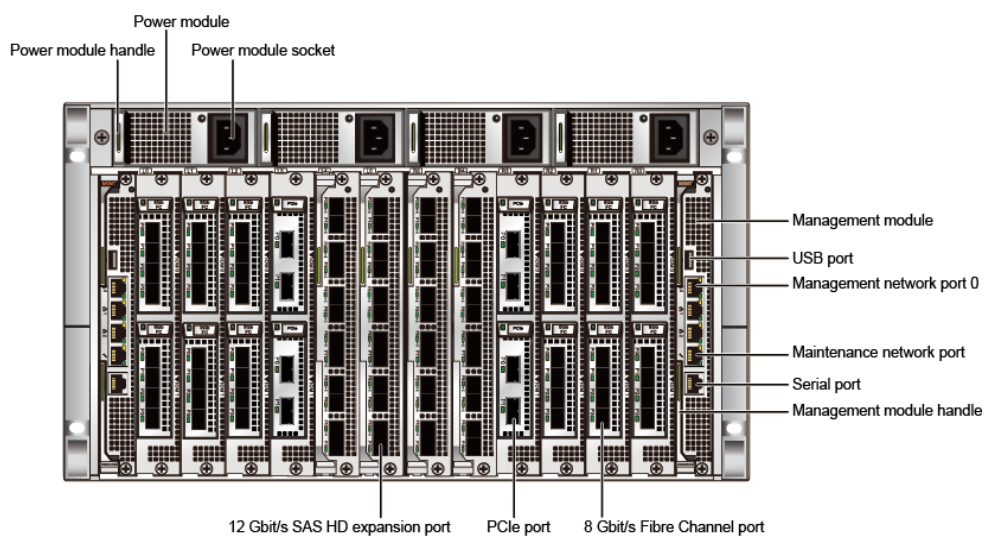
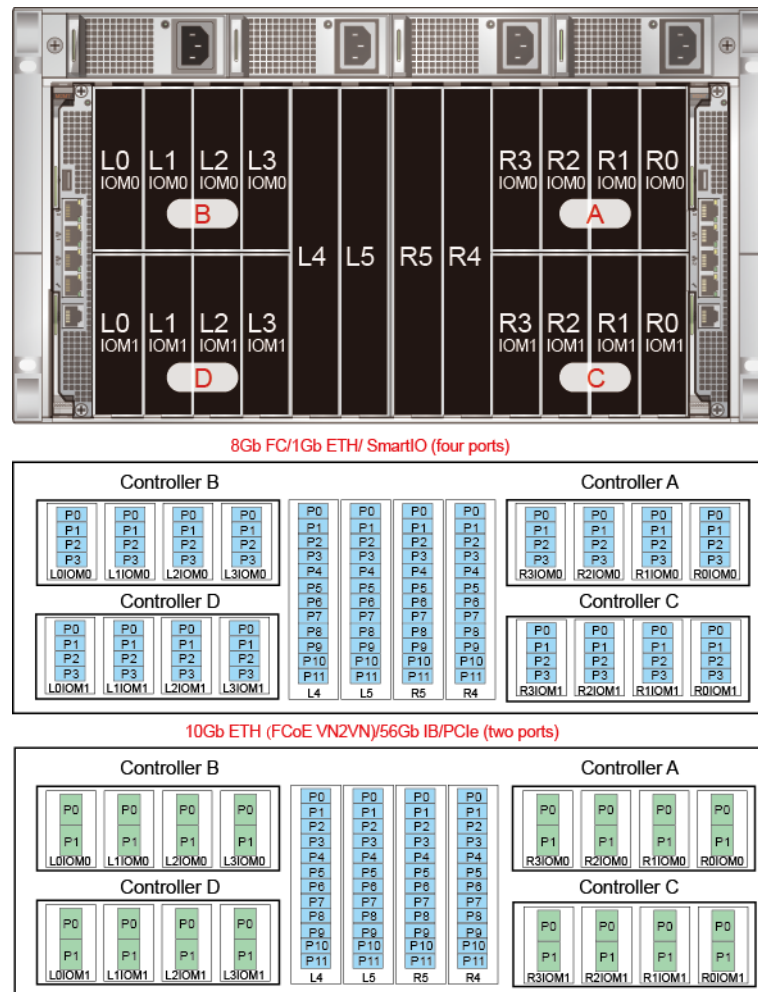

Figure 4-5 shows the interface module slots corresponding to controllers in an engine and the port mappings between them.

Figure 4-5 Interface module slots corresponding to controllers and their mapping relationships



NOTICE

The ports of an 8 Gbit/s Fibre Channel interface module (eight ports) are arranged in the sequence of P0 to P7.

You need to follow the rules as below when installing interface modules for engines.

- The slots on the interface modules of a 6 U engine are numbered as L0, L1, L2, L3, L4, L5, R5, R4, R3, R2, R1, and R0 from left to right and numbered as IOM0 and IOM1 from top to bottom.
- The first pair of 12 Gbit/s SAS shared expansion modules are installed in slots L5 and R5, and the second pair are installed in slots L4 and R4.
- PCIe interface modules are installed in slots L3 and R3.
- Front-end interface modules are installed in slots L0, L1, L2, R0, R1, and R2. Slots L4 and R4 can only be used once all the slots on the front-end interface modules are fully configured and SAS interface modules are not installed in slots L4 and R4.

- Except for SAS interface modules and PCIe interface modules, the rest interface modules are installed in the following sequence (R0/L0 to R3/L3): GE optical interface module > 10GE optical interface module > 8 Gbit/s Fibre Channel interface module (four ports) > 10 Gbit/s FCoE interface module > 56 Gbit/s IB interface module.

 **NOTE**

If both the Smart IO interface module and non-Smart IO interface module of the same specifications exist, install the non-Smart IO interface module first. When both the 8 Gbit/s Fibre Channel interface module (eight ports) and 8 Gbit/s Fibre Channel interface module (four ports) exist, install the 8 Gbit/s Fibre Channel interface module (eight ports) first. If some interface module is missing from the specification list, transfer its priority to the next interface module.

- Insert interface modules of the same type into a slot of controller A and the corresponding slot of controller B. Insert interface modules of the same type into a slot of controller C and the corresponding slot of controller D.

For example, if you insert an 8 Gbit/s Fibre Channel interface module (four ports) into slot R2IOM0 of controller A, you must insert an 8 Gbit/s Fibre Channel interface module (four ports) into slot L2IOM0 on controller B.

- Interface modules of the same type must be inserted in sequence.
- When the maintenance network port is used for management and maintenance, the maintenance network port can only be used by Huawei technical support for emergency maintenance and cannot be connected to the same network with the management network port. Otherwise, a network loopback may occur, causing a network storm. The initial IP addresses of maintenance network ports from system bay 0 to system bay 3 are 172.31.128.101 to 172.31.128.108. The default subnet mask is 255.255.0.0. You are advised to only connect the management network port to the network.

4.1.2 Component Description

An engine's component consists of controllers, (optional) assistant cooling units, fan modules, power modules, backup battery unit (BBU) modules, management modules, and interface modules.

Controller

A controller is the core component of a storage system. It processes storage services, receives configuration management commands, saves configuration data, connects to disk enclosures, and saves critical data onto coffer disks.

 **NOTE**

Each controller has one or more built-in disks to store system data. If a power failure occurs, such disks also store cache data. The disks built in one controller and those built in another are redundant for each other.

Figure 4-6 shows the appearance of a controller. **Figure 4-7** shows the front view of a controller.

Figure 4-6 Appearance of a controller



Figure 4-7 Front view of a controller

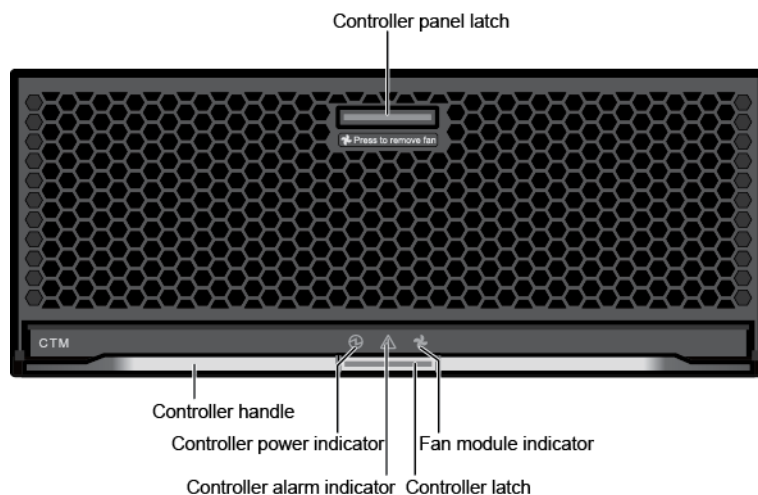

Table 4-1 describes the indicators on a controller of a storage system that is powered on.

Table 4-1 Indicators on a controller

Indicator	Status and Description
Fan module indicator	<ul style="list-style-type: none"> ● Steady green: The fan module is working correctly. ● Steady red: The fan module is faulty. ● Off: The fan module is powered off.
Controller alarm indicator	<ul style="list-style-type: none"> ● Steady red: An alarm about the controller is generated. ● Off: The controller is working correctly.

Indicator	Status and Description
Controller power indicator	<ul style="list-style-type: none"> ● Steady green: The controller is powered on. ● Blinking green (0.5 Hz): The controller is powered on and in the BIOS boot process. ● Blinking green (2 Hz): The controller is in the operating system boot process. ● Off: The controller cannot be detected or is powered off.

Assistant Cooling Unit

When two controllers are deployed in an engine, the assistant cooling units are inserted into the lower slots to help the engine in heat dissipation.

[Figure 4-8](#) shows the appearance of an assistant cooling unit. [Figure 4-9](#) shows the front view of an assistant cooling unit.

Figure 4-8 Appearance of an assistant cooling unit



Figure 4-9 Front view of an assistant cooling unit

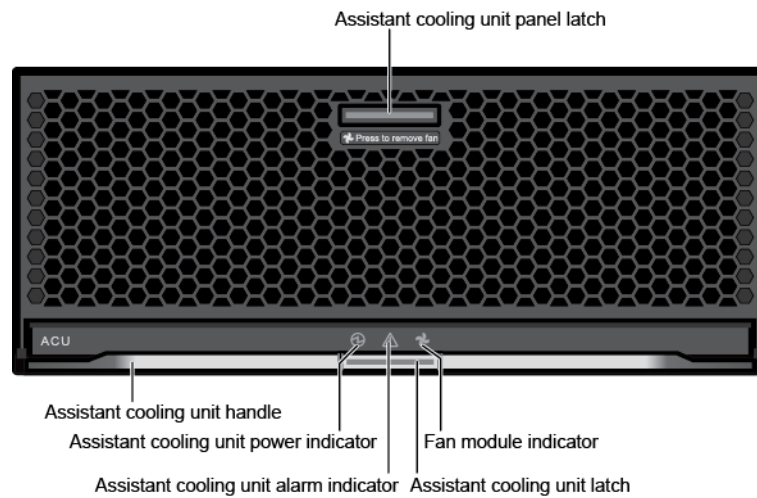

Table 4-2 describes the indicators on an assistant cooling unit of a storage system that is powered on.

Table 4-2 Indicators on an assistant cooling unit

Indicator	Status and Description
Fan module indicator	<ul style="list-style-type: none"> ● Steady green: The fan module is working correctly. ● Steady red: The fan module is faulty. ● Off: The fan module is powered off.
Assistant cooling unit alarm indicator	<ul style="list-style-type: none"> ● Steady red: An alarm about the assistant cooling unit is generated. ● Off: The assistant cooling unit is working correctly.
Assistant cooling unit power indicator	<ul style="list-style-type: none"> ● Steady green: The assistant cooling unit is powered on. ● Off: The assistant cooling unit cannot be detected or is powered off.

Fan Module

A fan module provides heat dissipation and enables an engine to work properly at the maximum power consumption.

Figure 4-10 shows the appearance of a fan module. **Figure 4-11** shows the front view of a fan module.

Figure 4-10 Appearance of a fan module



Figure 4-11 Front view of a fan module

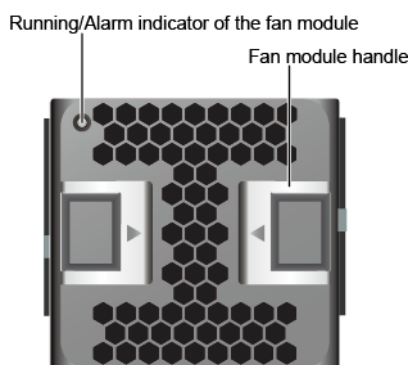

Table 4-3 describes indicators on a fan module of a powered-on storage system.

Table 4-3 Indicators on a fan module

Indicator	Status and Description
Running/Alarm indicator of the fan module	<ul style="list-style-type: none"> ● Steady green: The fan module is working correctly. ● Steady red: The fan module is faulty. ● Off: The fan module is powered off.

BBU

BBUs provide enough power to ensure that any data in flight is de-staged to the vault area in the event of a power failure. When the external power supply is normal, BBUs are standby. In the event of a power failure, BBUs provide power for the storage system. A faulty BBU can be isolated without affecting the normal running of the storage system. After the external power supply resumes, the driver reads data from the build-in disks of the controllers to the cache.

NOTE

In a system using the lithium batteries, the battery capacity is updated and detected by charging and discharging the batteries. In this way, the problems can be detected in advance that the battery capacity attenuates, the batteries fail to meet the power backup requirements of the system, and thus the data backup fails when the batteries are not used for a long time. Then, the reliability of data protection upon the system power failure can be improved.

Figure 4-12 shows the appearance of a BBU.

Figure 4-12 Appearance of a BBU



Table 4-4 describes the indicator on a BBU of a storage system that is powered on.

Table 4-4 Indicator on a BBU

Indicator	Status and Description
Running/Alarm indicator on a BBU	<ul style="list-style-type: none"> ● Steady green: The BBU is fully charged. ● Blinking green (1 Hz): The BBU is being charged. ● Blinking green (4 Hz): The BBU is being discharged. ● Steady red: The BBU is faulty. ● Off: The interface module is powered off or hot swappable.

Power Module

Power modules are AC power modules that allow a controller enclosure to work properly at the maximum power consumption.

Figure 4-13 shows the appearance of an AC power module.

Figure 4-13 AC power module

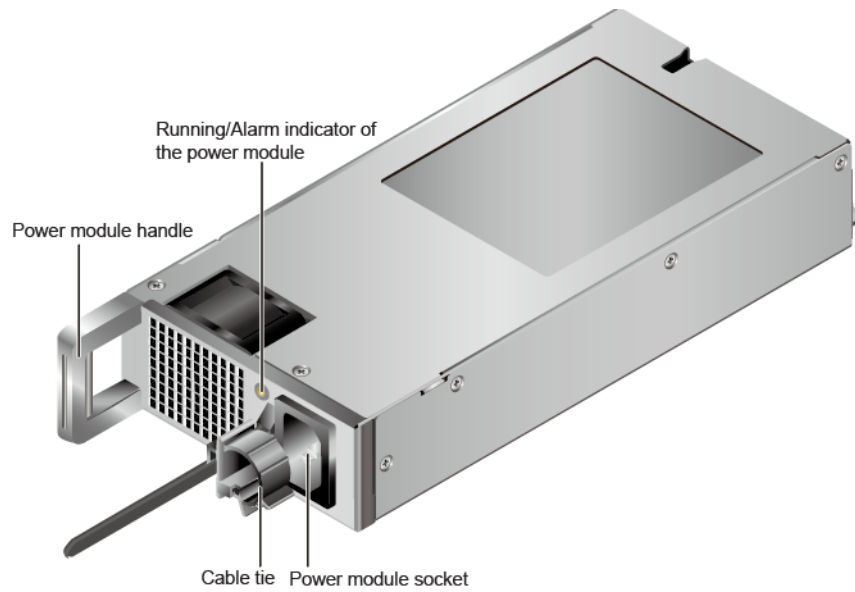

Table 4-5 describes indicators on a power module of a powered-on storage system.

Table 4-5 Indicators on a power module

Indicator	Status and Description
Running/Alarm indicator of the power module	<ul style="list-style-type: none"> ● Steady green: The power supply is correct. ● Green blinking: The power input is normal but the disk enclosure is powered off. ● Steady red: The power supply is faulty. ● Off: No external power input is found.

Management Module

A management module provides management ports, including a USB port, management network port, serial port, and maintenance network port.

Figure 4-14 shows a management module.

Figure 4-14 Management module

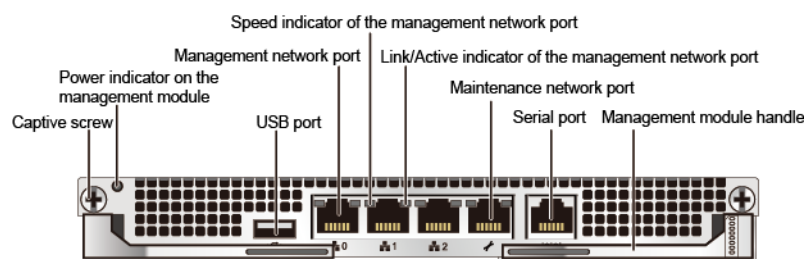

Table 4-6 describes the indicators on a management module of a storage system that is powered on.

Table 4-6 Indicators on a management module

Indicators	Status and Description
Power indicator on the management module	<ul style="list-style-type: none"> ● Steady green: The module is working correctly. ● Blinking green: The module receives a hot swap request. ● Steady red: The module is faulty. ● Off: The module is powered off or hot swappable.
Speed indicator of the management network port	<ul style="list-style-type: none"> ● Steady orange: Data is being transferred at the highest rate. ● Off: The data transfer speed is lower than the highest speed.
Link/Active indicator of the management network port	<ul style="list-style-type: none"> ● Steady green: The port is connected properly. ● Blinking green: Data is being transferred. ● Off: The port is connected abnormally.

8 Gbit/s Fibre Channel Interface Module (Four Ports)

The 8 Gbit/s Fibre Channel interface module (four ports) provides the service ports for the application server and the storage system. The service ports are used to receive data exchange commands sent by the application server. The Fibre Channel interface module provides four 8 Gbit/s Fibre Channel ports. If the port speed is auto-negotiable, the port will auto-negotiate 2 Gbit/s, 4 Gbit/s, or 8 Gbit/s. If the port speed is manually set but inconsistent with the data transfer speed of the connected application server, the connection will be interrupted.

Figure 4-15 shows an 8 Gbit/s Fibre Channel interface module (four ports).

Figure 4-15 8 Gbit/s Fibre Channel interface module (four ports)

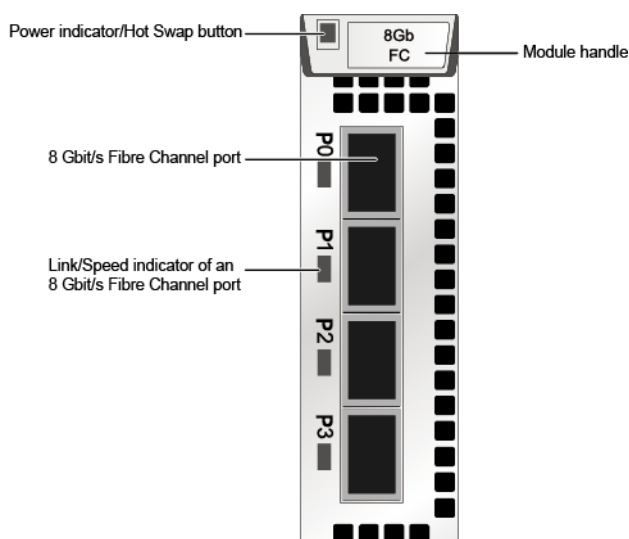

Table 4-7 describes indicators on an 8 Gbit/s Fibre Channel interface module (four ports) after it is powered on.

Table 4-7 Indicators on an 8 Gbit/s Fibre Channel interface module (four ports)

Indicator Name	Status and Description
Power indicator/Hot Swap button	<ul style="list-style-type: none"> ● Steady green: The interface module is working properly. ● Blinking green: There is a hot swap request to the module. ● Steady red: The module is faulty. ● Off: The module is powered off.
Link/Speed indicator of an 8 Gbit/s Fibre Channel port	<ul style="list-style-type: none"> ● Steady blue: The data transfer rate between the storage system and the application server is 8 Gbit/s. ● Blinking blue: Data transfer is in progress. ● Steady green: The data transfer rate between the storage system and the application server is 2 Gbit/s or 4 Gbit/s. ● Blinking green: Data transfer is in progress. ● Steady red: The port is faulty. ● Off: The link of the port is down.

GE Electrical Interface Module

A GE electrical interface module has four 1 Gbit/s electrical ports. These ports are the service ports used to connect the storage system to application servers and to receive read/write requests from application servers.

Figure 4-16 shows a GE electrical interface module.

Figure 4-16 GE electrical interface module

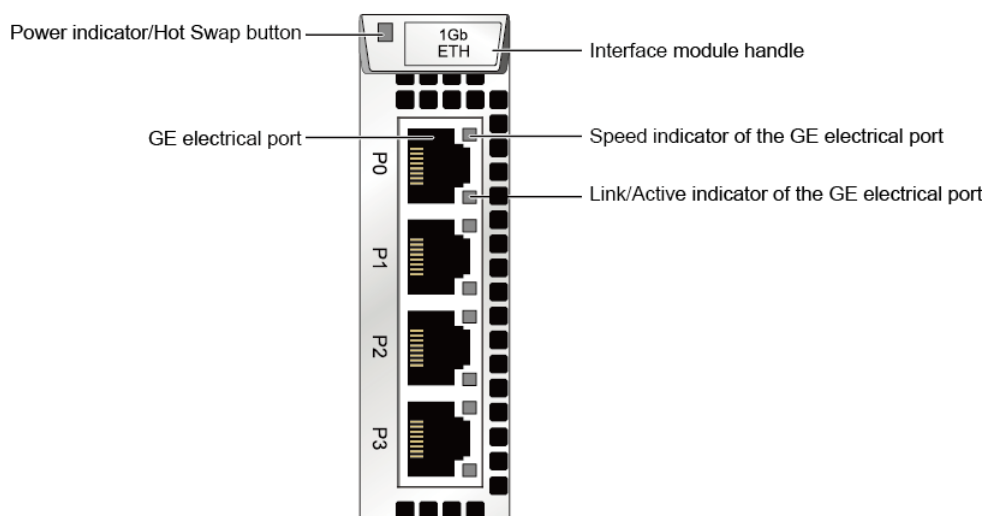

Table 4-8 describes indicators on a GE electrical interface module of a powered-on storage system.

Table 4-8 Indicators on a GE electrical interface module

Indicator	Status and Description
Power indicator/Hot Swap button	<ul style="list-style-type: none"> ● Steady green: The interface module is working correctly. ● Blinking green: There is a hot swap request to the module. ● Steady red: The module is faulty. ● Off: The interface module is powered off or hot swappable.
Link/Active indicator of the GE electrical port	<ul style="list-style-type: none"> ● Steady green: The link to the server is normal. ● Blinking green: Data is being transferred. ● Off: The link to the application server is down or no link exists.
Speed indicator of the GE electrical port	<ul style="list-style-type: none"> ● Steady orange: The data transfer rate between the storage system and the application server is 1 Gbit/s. ● Off: The data transfer rate between the storage system and the application server is less than 1 Gbit/s.

10GE Electrical Interface Module

A 10GE electrical interface module has four 10 Gbit/s electrical ports. These ports are the service ports used to connect the storage system to application servers and to receive read/write requests from application servers. 10GE electrical interface modules of the storage system support GE/10GE autonegotiation.

Figure 4-17 shows a 10GE electrical interface module.

Figure 4-17 10GE electrical interface module

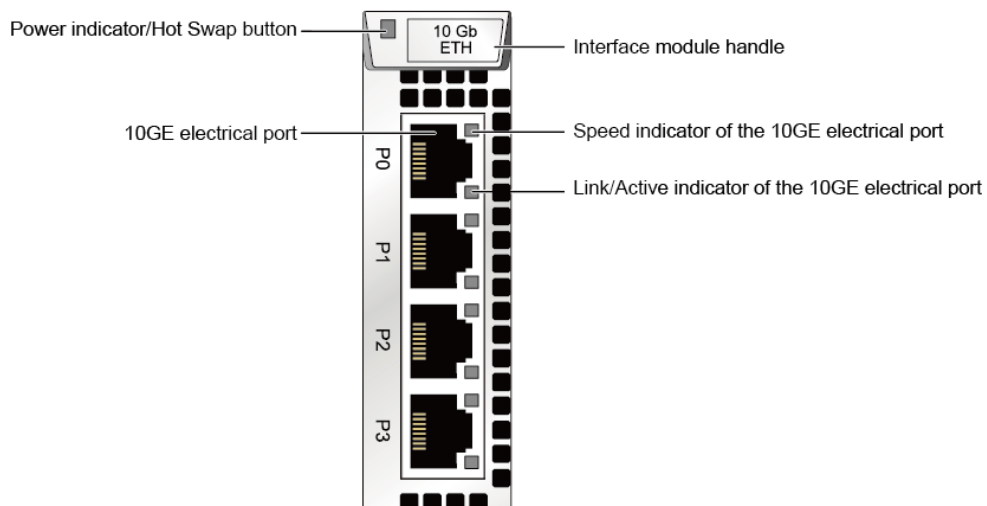

Table 4-9 describes indicators on a 10GE electrical interface module of a powered-on storage system.

Table 4-9 Indicators on a 10GE electrical interface module

Indicator	Status and Description
Power indicator/Hot Swap button	<ul style="list-style-type: none"> ● Steady green: The interface module is working correctly. ● Blinking green: There is a hot swap request to the module. ● Steady red: The module is faulty. ● Off: The interface module is powered off or hot swappable.
Link/Active indicator of the 10GE electrical port	<ul style="list-style-type: none"> ● Steady green: The link to the server is normal. ● Blinking green: Data is being transferred. ● Off: The link to the application server is down or no link exists.
Speed indicator of the 10GE electrical port	<ul style="list-style-type: none"> ● Steady orange: The data transfer rate between the storage system and the application server is 10 Gbit/s. ● Off: The data transfer rate between the storage system and the application server is less than 10 Gbit/s.

10 Gbit/s FCoE Interface Module (Two Ports)

A 10 Gbit/s FCoE interface module provides two 10 Gbit/s FCoE ports for the storage device to connect to application servers and to receive read/write requests from the application servers.

Figure 4-18 shows a 10 Gbit/s FCoE interface module.

 **NOTE**

- A 10 Gbit/s two-port FCoE interface module only supports direct connection networking.
- You are not advised to run iSCSI and FCoE protocols simultaneously on a 10 Gbit/s two-port FCoE interface module to ensure system performance.

Figure 4-18 10 Gbit/s FCoE interface module (Two Ports)

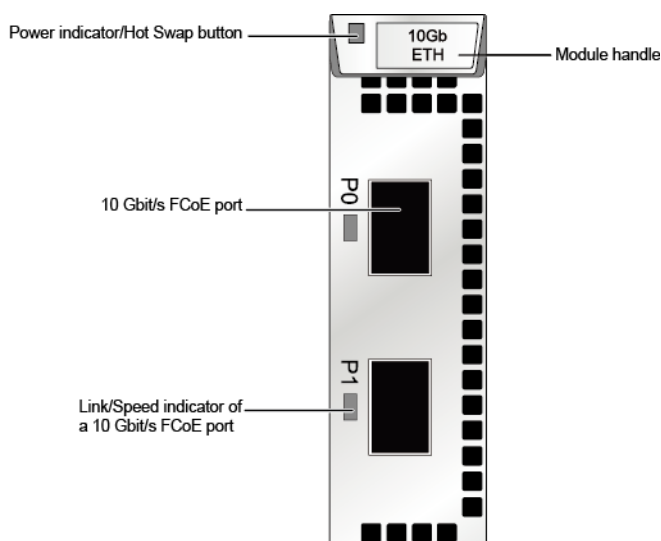

Table 4-10 describes indicators on a 10 Gbit/s FCoE interface module after it is powered on.

Table 4-10 Indicators on a 10 Gbit/s FCoE interface module

Indicator Name	Status and Description
Power indicator/Hot Swap button	<ul style="list-style-type: none"> ● Steady green: The interface module is working properly. ● Blinking green: There is a hot swap request to the module. ● Steady red: The module is faulty. ● Off: The module is powered off.
Link/Speed indicator of a 10 Gbit/s FCoE port	<ul style="list-style-type: none"> ● Steady blue: The data transfer rate between the storage system and the application server is 10 Gbit/s. ● Blinking blue: Data transfer is in progress. ● Steady red: The port is faulty. ● Off: The link of the port is down.

PCIe Interface Module

A PCIe interface module provides two PCIe ports as the service ports connecting engines to the data switch for the engines to exchange control flow and data flow.

Figure 4-19 shows a PCIe interface module.

Figure 4-19 PCIe interface module

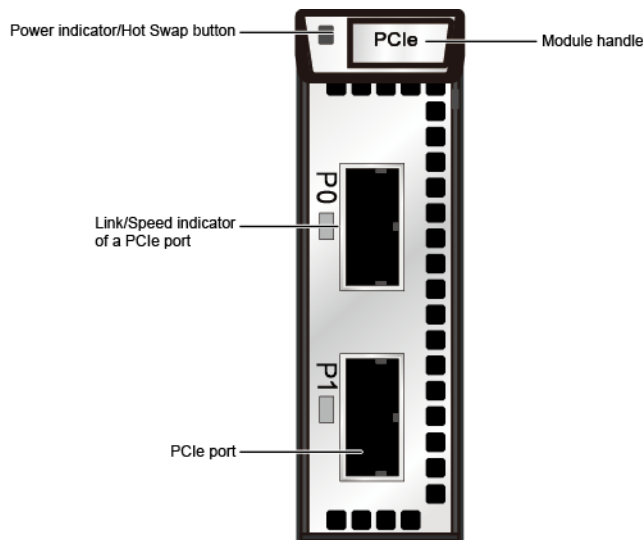

Table 4-11 describes indicators on a PCIe interface module after it is powered on.

Table 4-11 Indicators on a PCIe interface module

Indicator Name	Status and Description
Power indicator/Hot Swap button	<ul style="list-style-type: none"> ● Steady green: The interface module is working properly. ● Blinking green: There is a hot swap request to the module. ● Steady red: The interface module is faulty. ● Off: The module is powered off.
Link/Speed indicator of a PCIe port	<ul style="list-style-type: none"> ● Steady blue: The data transfer rate between the PCIe port and the data switch is 5 Gbit/s. ● Steady green: The data transfer rate between the PCIe port and the data switch is 2.5 Gbit/s. ● Steady red: The port is faulty. ● Off: The link of the port is down.

12 Gbit/s SAS Shared Expansion Module

A 12 Gbit/s SAS shared expansion module on an engine provides twelve 4 x 12 Gbit/s mini SAS ports to connect the engine to a disk enclosure through a mini SAS cable. When the transfer rate of the connected device is less than that of the expansion port, the expansion port automatically adjusts the transfer rate to that of the connected device to ensure the connectivity of the data transfer channel.

Figure 4-20 shows a 12 Gbit/s SAS shared expansion module.

Figure 4-20 12 Gbit/s SAS shared expansion module

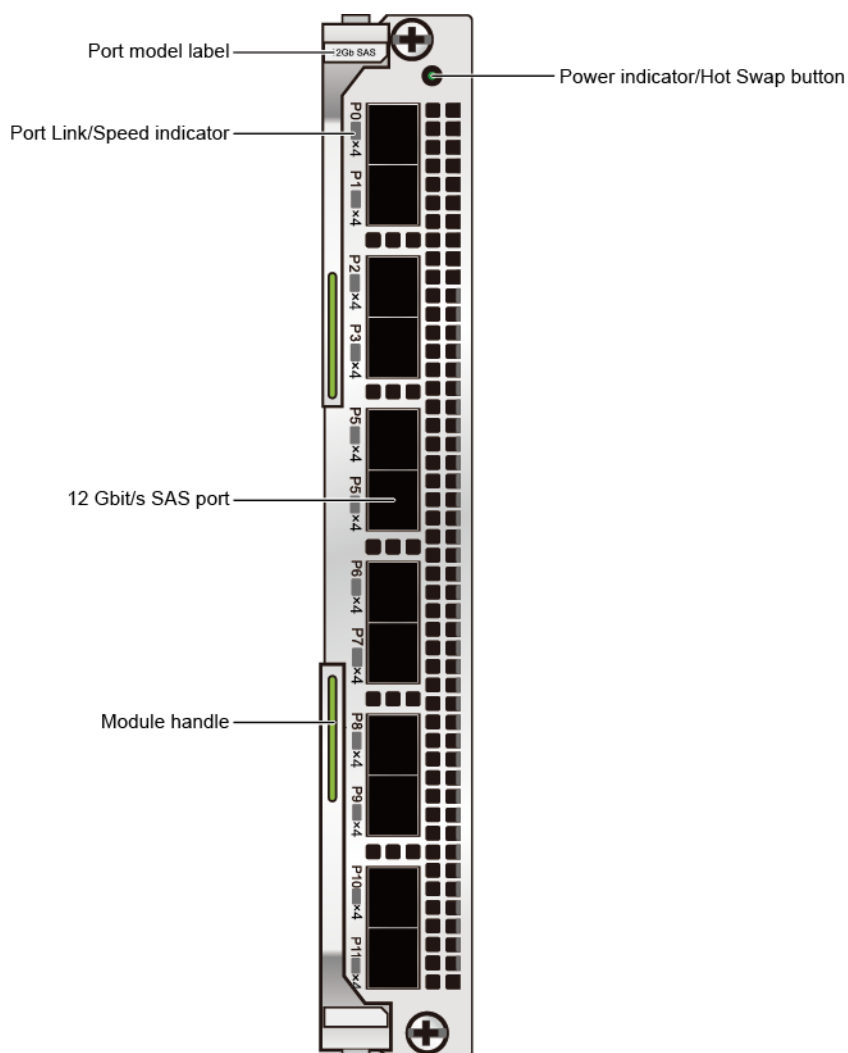

Table 4-12 describes indicators on a 12 Gbit/s SAS shared expansion module after it is powered on.

Table 4-12 Indicators on a 12 Gbit/s SAS shared expansion module

Indicator Name	Status and Description
Port Link/Speed indicator	<ul style="list-style-type: none"> ● Steady blue: Data is being transferred at the highest rate. ● Steady green: The data transfer speed is lower than the highest speed. ● Steady red: The port is faulty. ● Blinking red: The module is being located. ● Off: The link of the port is down.

Indicator Name	Status and Description
Power indicator/Hot Swap button	<ul style="list-style-type: none"> ● Steady green: The module is working properly. ● Blinking green: There is a hot swap request to the module. ● Steady red: The module is faulty. ● Off: The module is powered off.

SmartIO Interface Module

A SmartIO interface module provides 8 Gbit/s, 10 Gbit/s, and 16 Gbit/s optical transceiver. They are the service ports used to connect to application servers and to receive read/write instructions from application servers.

Figure 4-21 shows the components of a SmartIO interface module.

Figure 4-21 SmartIO interface module

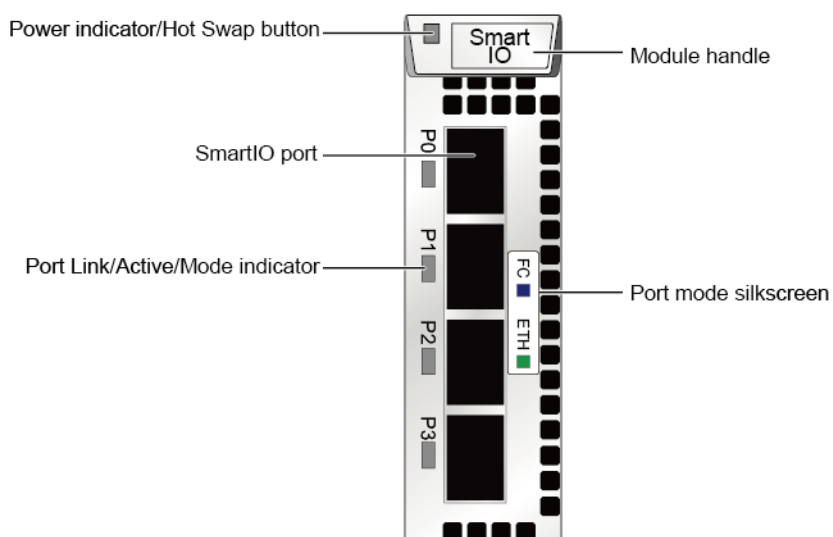

Table 4-13 describes the states of indicators and their meanings on a SmartIO interface module after the storage device is powered on.

Table 4-13 Indicator status description for a SmartIO interface module

Indicator	Status Description
Module Power/Hot Swap button	<ul style="list-style-type: none"> ● Steady green: The interface module is running properly. ● Blinking green: The interface module receives a hot swap request. ● Steady red: The interface module is faulty. ● Off: The interface module is not powered on or can be hot-swappable.
Port Link/Active/Mode indicator	<ul style="list-style-type: none"> ● Blinking blue slowly (1 Hz): The interface module is working in FC mode, and the port link is down. ● Blinking blue quickly (2 Hz): The interface module is working in FC mode, and data is being transmitted. ● Steady blue: The interface module is working in FC mode, the port link is up, and no data is being transmitted. ● Blinking green slowly (1 Hz): The interface module is working in ETH mode, and the port link is down. ● Blinking green quickly (2 Hz): The interface module is working in ETH mode, and data is being transmitted. ● Steady green: The interface module is working in ETH mode, the port link is up, and no data is being transmitted. ● Steady red: The port is faulty. ● Off: The port is not powered on.

 **NOTE**

- If the mode of the SmartIO port is set to **FCoE/iSCSI** or **Cluster** on the software interface, the port indicator is in ETH mode and a 10 Gbit/s optical module is required. 10 Gbit/s optical transceiver does not support GE/10GE autonegotiation.
- If the mode of the SmartIO port is set to **FC** on the software interface, the port indicator is in FC mode, and an 8 Gbit/s or 16 Gbit/s optical module is required.
- If the mode of the SmartIO interface module is set to **FCoE/iSCSI** and the host uses the FCoE protocol, the module must connect to FCoE switches for networking and a 10 Gbit/s optical module is required.
- If the mode of the SmartIO interface module is set to **FCoE/iSCSI** and the host uses the iSCSI protocol, the MTU value of the SmartIO port must be the same as that of the host.

56 Gbit/s InfiniBand Interface Module

A 56 Gbit/s InfiniBand interface module provides two 4 x 14 Gbit/s InfiniBand ports. Both are the service ports used to connect to application servers and to receive read/write instructions from application servers.

Figure 4-22 shows the appearance of a 56 Gbit/s InfiniBand interface module.

Figure 4-22 56 Gbit/s InfiniBand interface module

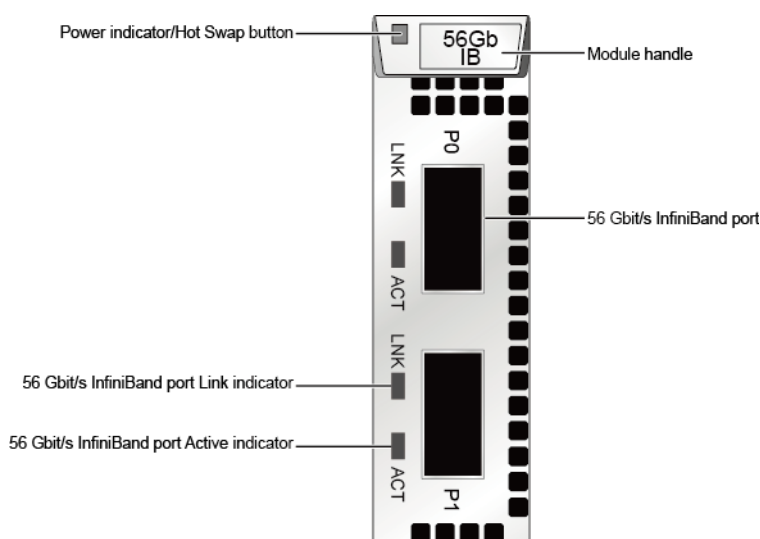

Table 4-14 describes the states of indicators and their meanings on a 56 Gbit/s InfiniBand interface module after the storage device is powered on.

Table 4-14 Indicator status description for a 56 Gbit/s InfiniBand interface module

No.	Indicator	Status Description
1	Power indicator/Hot Swap button	<ul style="list-style-type: none"> ● Steady green: The interface module is running properly. ● Blinking green: The interface module receives a hot swap request. ● Steady red: The interface module is faulty. ● Off: The interface module is not powered on or can be hot-swappable.
2	56 Gbit/s InfiniBand port Link indicator	<ul style="list-style-type: none"> ● Steady green: The port is connected properly. ● Off: The port link is down.
3	56 Gbit/s InfiniBand port Active indicator	<ul style="list-style-type: none"> ● Steady orange: Data is being transmitted. ● Off: No data is being transmitted.

8 Gbit/s Fibre Channel Interface Module (Eight Ports)

An 8 Gbit/s Fiber Channel interface module (eight ports) provides two ports and can be converted to eight 8 Gbit/s Fibre Channel ports through dedicated fiber cables. These Fibre Channel ports can be used for a storage system to receive data exchange commands from application servers. If the port speed is auto-negotiable, the port will auto-negotiate 2 Gbit/s, 4 Gbit/s, or 8 Gbit/s. If the port speed is manually set but inconsistent with the data transfer speed of the connected application server, the connection will be interrupted.

Figure 4-23 shows the appearance of an 8 Gbit/s Fibre Channel interface module (eight ports).

Figure 4-23 8 Gbit/s FC interface module (eight ports)

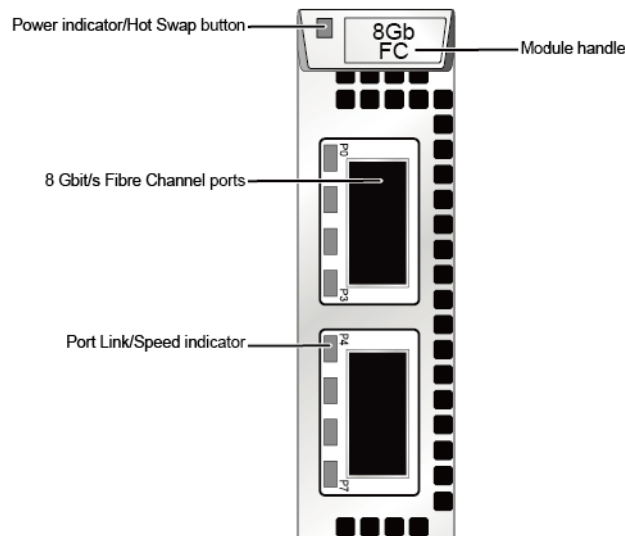

Table 4-15 describes the states of indicators and their meanings on an 8 Gbit/s Fibre Channel interface module (eight ports) after the storage device is powered on.

Table 4-15 Indicator status description for an 8 Gbit/s Fibre Channel interface module (eight ports)

Indicator	Status Description
Module Power/Hot Swap indicator	<ul style="list-style-type: none"> ● Steady green: The interface module is running properly. ● Blinking green: The interface module receives a hot swap request. ● Steady red: The interface module is faulty. ● Off: The interface module is not powered on or can be hot-swappable.
Link/Speed indicator of the 8 Gbit/s Fibre Channel host port	<ul style="list-style-type: none"> ● Steady blue: Data is being transmitted between the storage system and the application server at a rate of 8 Gbit/s. ● Blinking blue: Data is being transferred. ● Steady green: Data is being transmitted between the storage system and the application server at a rate of 2 Gbit/s or 4 Gbit/s. ● Blinking green: Data is being transmitted. ● Steady red: The port is faulty. ● Off: The port link is down.

16Gbit/s Fibre Channel Interface Module (Eight Ports) (Supported by OceanStor 18500F V5)

A 16 Gbit/s Fiber Channel interface module (eight ports) provides two ports and can be converted to eight 16 Gbit/s Fibre Channel ports through dedicated fiber cables. These Fibre Channel ports can be used for a storage system to receive data exchange commands from application servers. If the port speed is auto-negotiable, the port will auto-negotiate 4 Gbit/s, 8 Gbit/s, or 16 Gbit/s. If the port speed is manually set but inconsistent with the data transfer speed of the connected application server, the connection will be interrupted.

Figure 4-24 shows the appearance of a 16 Gbit/s Fibre Channel interface module (eight ports).

Figure 4-24 16 Gbit/s FC interface module (eight ports)

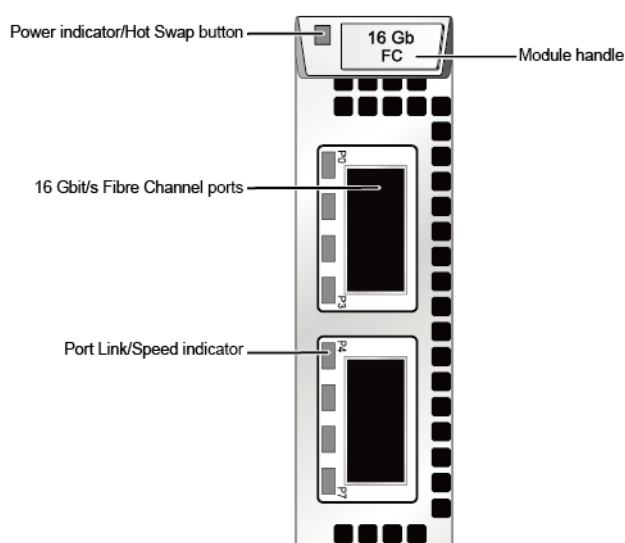

Table 4-16 describes the states of indicators and their meanings on a 16 Gbit/s Fibre Channel interface module (eight ports) after the storage device is powered on.

Table 4-16 Indicator status description for a 16 Gbit/s Fibre Channel interface module (eight ports)

Indicator	Status Description
Power indicator/Hot Swap button	<ul style="list-style-type: none"> ● Steady green: The interface module is running properly. ● Blinking green: The interface module receives a hot swap request. ● Steady red: The interface module is faulty. ● Off: The interface module is not powered on or can be hot-swappable.

Indicator	Status Description
Link/Speed indicator of the 8 Gbit/s Fibre Channel host port	<ul style="list-style-type: none"> ● Steady blue: Data is being transmitted between the storage system and the application server at a rate of 16 Gbit/s. ● Blinking blue: Data is being transferred. ● Steady green: Data is being transmitted between the storage system and the application server at a rate of 4 Gbit/s or 8 Gbit/s. ● Blinking green: Data is being transmitted. ● Steady red: The port is faulty. ● Off: The port link is down.

4.1.3 Indicator Introduction

After an engine is powered on, you can check the current operating status of the engine by viewing its indicators.

Indicators on the Front Panel

Figure 4-25 shows the indicators on the front panel of an engine.

Figure 4-25 Indicators on the front panel of an engine

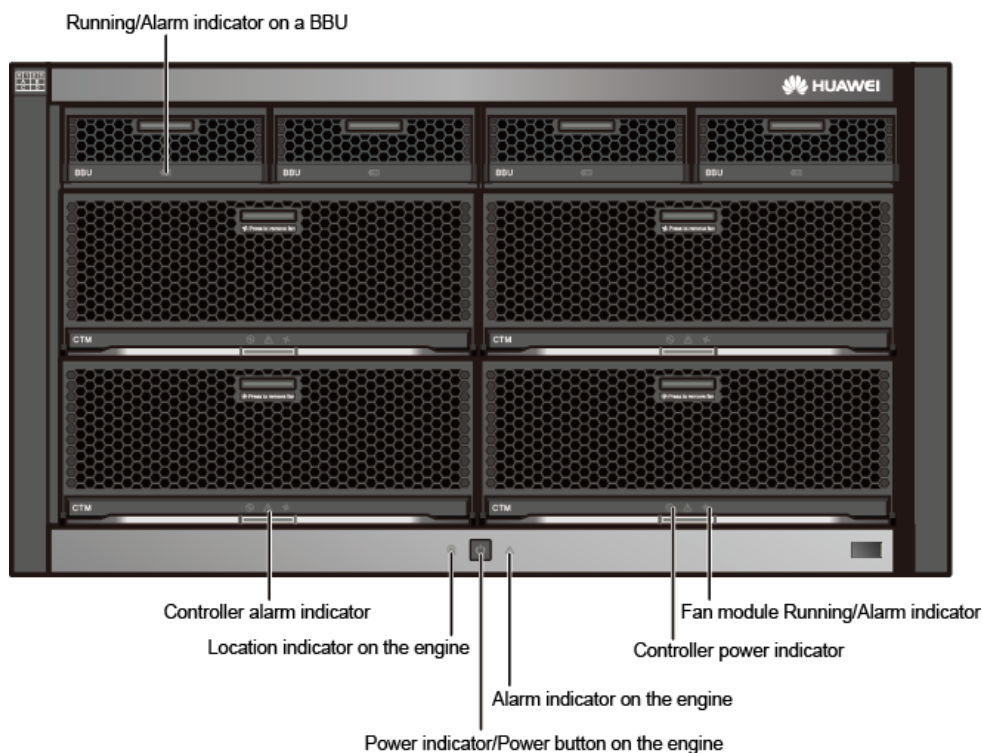

Table 4-17 describes the indicators on the front panel of an engine.

Table 4-17 Indicators on the front panel of an engine

Module	Indicator	Status and Description
BBU	Running/Alarm indicator on a BBU	<ul style="list-style-type: none"> ● Steady green: The BBU is fully charged. ● Blinking green (1 Hz): The BBU is being charged. ● Blinking green (4 Hz): The BBU is being discharged. ● Steady red: The BBU is faulty.
Controller	Fan module Running/Alarm indicator	<ul style="list-style-type: none"> ● Steady green: Fan modules are working correctly. ● Steady red: The fan module is faulty. ● Off: Fan modules are powered off.
	Controller power indicator	<ul style="list-style-type: none"> ● Steady green: The controller is powered on. ● Blinking green (0.5 Hz): The controller is powered on and in the BIOS boot process. ● Blinking green (2 Hz): The controller is in the operating system boot process. ● Off: The controller cannot be detected or is powered off.
System subrack	Alarm indicator on the engine	<ul style="list-style-type: none"> ● Steady red: An alarm about the engine is generated. ● Off: The engine is working properly.
	Power indicator/Power button on the engine	<ul style="list-style-type: none"> ● Steady green: The engine is powered on. ● Blinking green (0.5 Hz): The engine is powered on for a short time. ● Blinking green (1 Hz): The engine is in the burn-in test. ● Blinking green (2 Hz): The engine is in the operating system boot process, or is being powered off. ● Off: The engine is powered off or powered by BBUs.
	Location indicator on the engine	<ul style="list-style-type: none"> ● Blinking blue: The engine is being located. ● Off: The engine is not located.

Module	Indicator	Status and Description
Controller	Controller alarm indicator	<ul style="list-style-type: none"> ● Steady red: An alarm about the controller is generated. ● Off: The controller is working correctly.

Indicators on the Rear Panel

Figure 4-26 shows the indicators on the rear panel of an engine.

Figure 4-26 Indicators on the rear panel of an engine

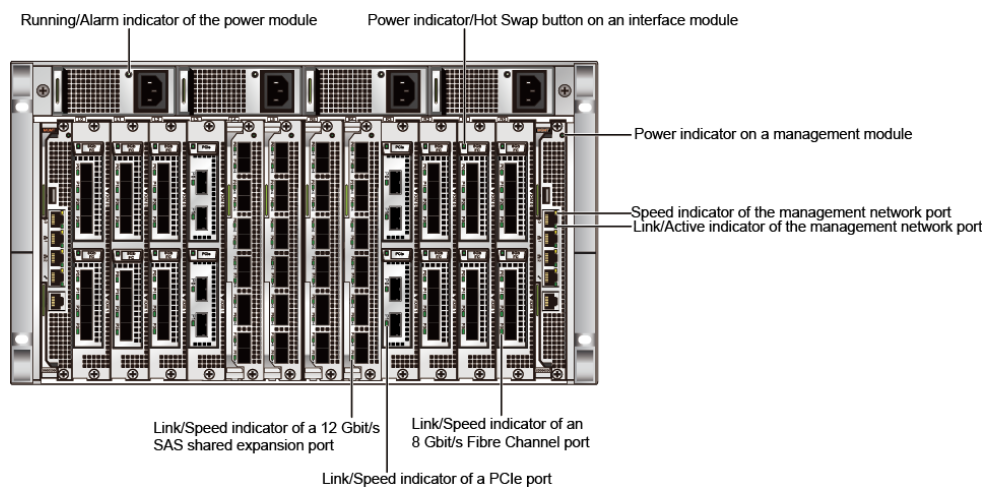

Table 4-18 describes the indicators on the rear panel of an engine.

Table 4-18 Indicators on the rear panel of an engine

Module	Indicator	Status and Description
Power module	Running/Alarm indicator of the power module	<ul style="list-style-type: none"> ● Steady green: The power supply is normal. ● Blinking green: The power input is normal but the device is powered off. ● Steady red: The power module is faulty. ● Off: No external power input is available.
Interface module	Power indicator/Hot Swap button on an interface module	<ul style="list-style-type: none"> ● Steady green: The interface module is working correctly. ● Blinking green: The interface module receives a hot swap request. ● Steady red: The interface module is faulty. ● Off: The interface module is powered off or hot swappable.

Module	Indicator	Status and Description
Management module	Power indicator on a management module	<ul style="list-style-type: none"> ● Steady green: The module is working correctly. ● Blinking green: The module receives a hot swap request. ● Steady red: The module is faulty. ● Off: The module is powered off or hot swappable.
	Speed indicator of the management network port	<ul style="list-style-type: none"> ● Steady orange: Data is being transferred at the highest rate. ● Off: The data transfer speed is lower than the highest speed.
	Link/Active indicator of the management network port	<ul style="list-style-type: none"> ● Steady green: The port is connected properly. ● Blinking green: Data is being transferred. ● Off: The port is connected abnormally.
Interface module	Link/Speed indicator of an 8 Gbit/s Fibre Channel port	<ul style="list-style-type: none"> ● Steady blue: The data transfer rate between the storage system and the application server is 8 Gbit/s. ● Blinking blue: Data transfer is in progress. ● Steady green: The data transfer rate between the storage system and the application server is 2 Gbit/s or 4 Gbit/s. ● Blinking green: Data transfer is in progress. ● Steady red: The port is faulty. ● Off: The link of the port is down.
	Link/Speed indicator of a PCIe port	<ul style="list-style-type: none"> ● Steady blue: The data transfer rate between the PCIe port and the data switch is 5 Gbit/s. ● Steady green: The data transfer rate between the PCIe port and the data switch is 2.5 Gbit/s. ● Steady red: The port is faulty. ● Off: The link of the port is down.
	Link/Speed indicator of a 12 Gbit/s SAS shared expansion port	<ul style="list-style-type: none"> ● Steady blue: Data is being transferred at the highest rate. ● Steady green: The data transfer speed is lower than the highest speed. ● Steady red: The port is faulty. ● Blinking red: The module is being located. ● Off: The link of the port is down.

4.2 2 U Disk Enclosure (2.5-Inch Disks)

This section describes a disk enclosure in terms of its hardware structure, component functions, front and rear views, and indicators.

4.2.1 Overview

The disk enclosure consists of a system subrack, expansion modules, disk modules, and power modules.

Overall Structure

Figure 4-27 shows the overall structure of a disk enclosure.

Figure 4-27 Overall structure of a disk enclosure with AC power modules

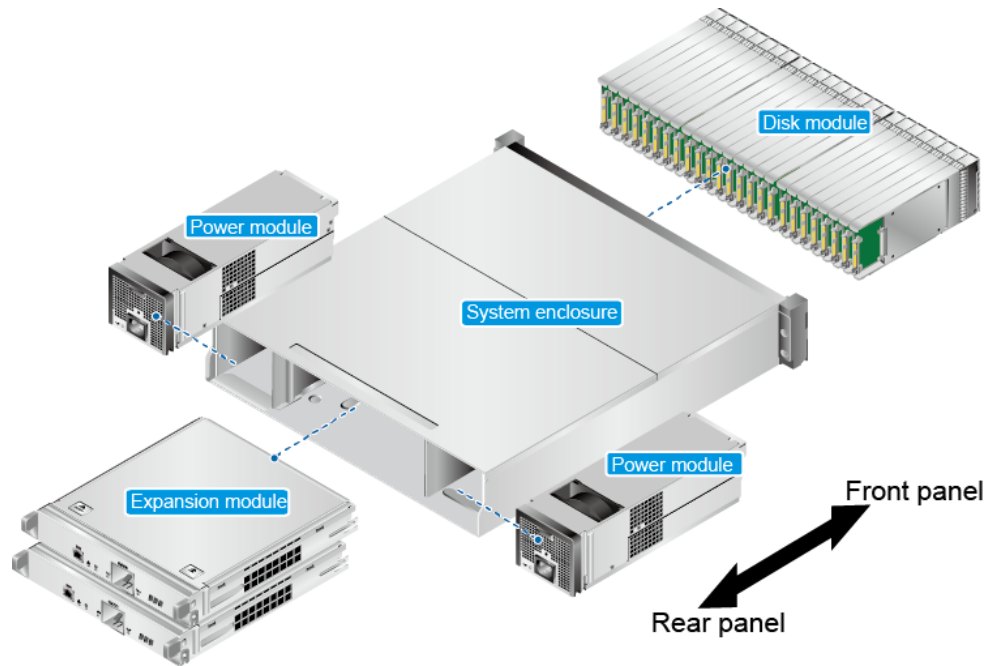

Front view

Figure 4-28 shows the front view of a 2 U disk enclosure.

Figure 4-28 Front view of a 2 U disk enclosure

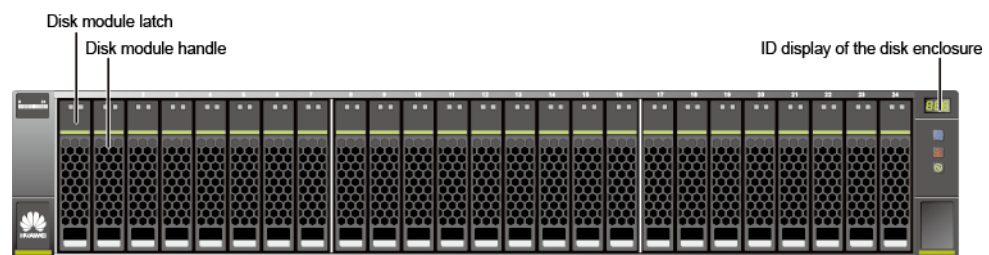

NOTE

The disk slots of a 2 U disk enclosure are numbered 0 to 24 from left to right. The first four disks in the first disk enclosure that is connected to the engine are coffer disks. The coffer disks are inserted into slot 0 to slot 3.

Rear View

Figure 4-29 shows the rear view of a disk enclosure with the AC power module.

Figure 4-29 Rear view of a disk enclosure with the AC power module

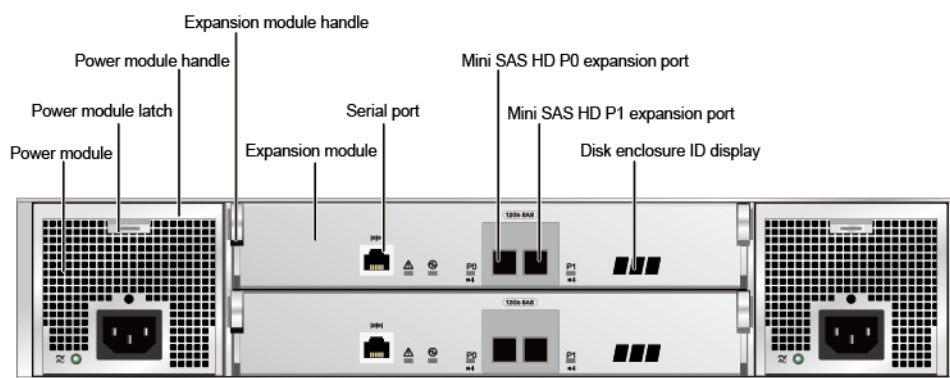

4.2.2 Component Description

This section provides the illustration and description of each component of the storage system.

4.2.2.1 System Subrack

The system subrack integrates a midplane in order to provide reliable connections for interface modules and to distribute power and signals to inner modules.

Appearance

Figure 4-30 shows the appearance of a system subrack.

Figure 4-30 System subrack



4.2.2.2 Expansion Module

An expansion module provides expansion ports for communication between the disk enclosure and the engine. Each expansion module provides a P0 expansion port and a P1 expansion port.

Appearance

Figure 4-31 shows the appearance of an expansion module.

Figure 4-31 Expansion module



Ports

Figure 4-32 shows the ports of an expansion module.

Figure 4-32 Interfaces of an expansion module

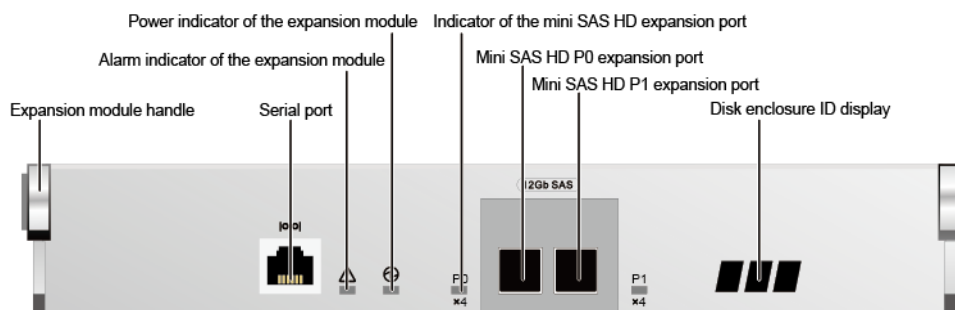

Indicators

Table 4-19 describes indicators on an expansion module of a powered-on storage system.

Table 4-19 Indicators on an expansion module

Indicator	Status and Description
Alarm indicator of the expansion module	<ul style="list-style-type: none"> ● Steady red: An alarm is generated in the expansion module. ● Off: The expansion module is working correctly.
Power indicator of the expansion module	<ul style="list-style-type: none"> ● Steady green: The expansion module is powered on. ● Off: The expansion module is powered off.
Mini SAS HD expansion port indicator	<ul style="list-style-type: none"> ● Steady green: The link to the expansion port is normal and the data transfer rate is 4 x 3 Gbit/s or 4 x 6 Gbit/s. ● Steady blue: The link to the expansion port is normal and the data transfer rate is 4 x 12 Gbit/s. ● Steady red: The port is faulty. ● Off: The link to the expansion port is down.

4.2.2.3 Power Module

The storage system supports AC power modules. Power modules can ensure that the disk enclosure works correctly in maximum power consumption mode.

Appearance

Figure 4-33 shows the appearance of an AC power module.

Figure 4-33 AC power module

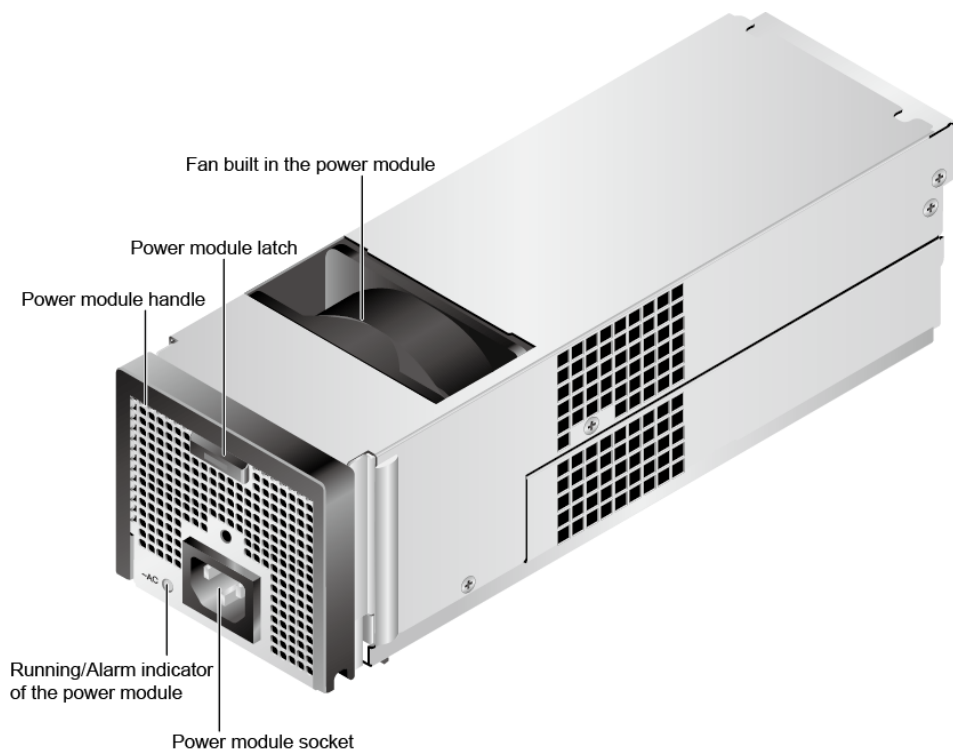

Indicators

Table 4-20 describes indicators on a power module of a powered-on storage system.

Table 4-20 Indicators on a power module

Indicator	Status and Description
Running/Alarm indicator of the power module	<ul style="list-style-type: none">● Steady green: The power supply is correct.● Blinking green: The power input is normal but the disk enclosure is powered off.● Steady red: The power module is faulty.● Off: No external power input is found.

4.2.2.4 Disk Module

Disk modules provide storage capacity for a storage system. Service data, system data, and cache data are all saved on disk modules.

Appearance

Figure 4-34 shows the appearance of a disk module.

Figure 4-34 Disk module

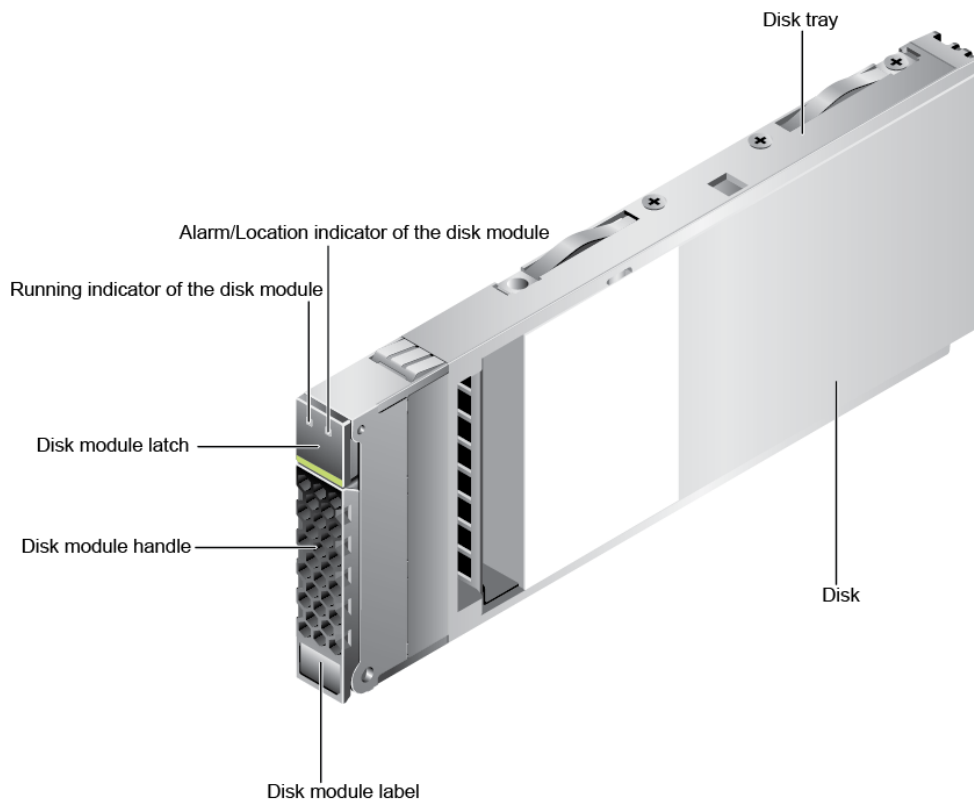

Indicators

Table 4-21 describes indicators on a disk module of a powered-on storage system.

Table 4-21 Indicators on a disk module

Indicator	Status and Description
Running indicator of the disk module	<ul style="list-style-type: none"> ● Steady green: The disk module is working correctly. ● Blinking green: Data is being read and written on the disk module. ● Off: The disk module is powered off or powered on incorrectly.
Alarm/Location indicator of the disk module	<ul style="list-style-type: none"> ● Steady red: The disk module is faulty. ● Blinking red: The disk module is being located. ● Off: The disk module is working correctly or hot swappable.

4.2.3 Indicator Introduction

After a disk enclosure is powered on, you can check the current operating status of the disk enclosure by viewing its indicators.

Indicators on the Front Panel

Figure 4-35 shows the indicators on the front panel of a disk enclosure.

Figure 4-35 Indicators on the front panel of a disk enclosure

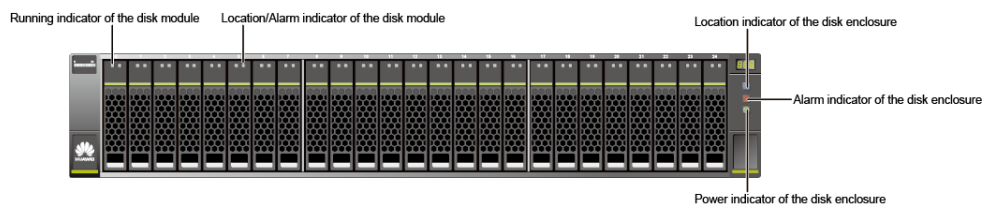

Table 4-22 describes the indicators on the front panel of the disk enclosure.

Table 4-22 Description of the indicators on the front panel of a disk enclosure

Module	Indicator	Status and Description
Disk module	Running indicator of the disk module	<ul style="list-style-type: none"> ● Steady green: The disk module is working correctly. ● Blinking green: Data is being read and written on the disk module. ● Off: The disk module is powered off or powered on incorrectly.

Module	Indicator	Status and Description
	Alarm/Location indicator of the disk module	<ul style="list-style-type: none"> ● Steady red: The disk module is faulty. ● Blinking red: The disk module is being located. ● Off: The disk module is working correctly or hot swappable.
System enclosure	Location indicator of the disk enclosure	<ul style="list-style-type: none"> ● Blinking blue: The disk enclosure is being located. ● Off: The disk enclosure is not detected.
	Alarm indicator of the disk enclosure	<ul style="list-style-type: none"> ● Steady red: An alarm is generated in the disk enclosure. ● Off: The disk enclosure is working correctly.
	Power indicator of the disk enclosure	<ul style="list-style-type: none"> ● Steady green: The disk enclosure is powered on. ● Off: The disk enclosure is powered off.

Indicators on the Rear Panel

Figure 4-36 shows the indicators on the rear panel of a disk enclosure.

Figure 4-36 Indicators on the rear panel of a disk enclosure

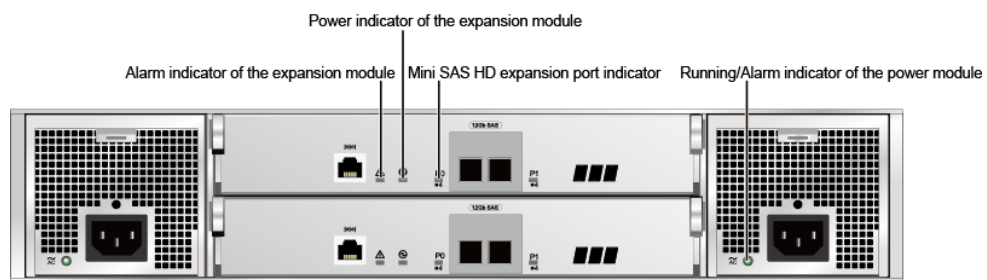

Table 4-23 describes the indicators on the rear panel of the disk enclosure.

Table 4-23 Description of the indicators on the rear panel of a disk enclosure

Module	Indicator	Status and Description
Expansion module	Alarm indicator of the expansion module	<ul style="list-style-type: none"> ● Steady red: An alarm is generated on the expansion module. ● Off: The expansion module is working correctly.

Module	Indicator	Status and Description
	Power indicator of the expansion module	<ul style="list-style-type: none"> ● Steady green: The expansion module is powered on. ● Off: The expansion module is powered off.
	Mini SAS HD expansion port indicator	<ul style="list-style-type: none"> ● Steady green: The link to the expansion port is normal and the data transfer rate is 4 x 3 Gbit/s or 4 x 6 Gbit/s. ● Steady blue: The link to the expansion port is normal and the data transfer rate is 4 x 12 Gbit/s. ● Steady red: The port is faulty. ● Off: The link to the expansion port is down.
Power module	Running/Alarm indicator of the power module	<ul style="list-style-type: none"> ● Steady green: The power supply is correct. ● Blinking green: The power input is normal but the disk enclosure is powered off. ● Steady red: The power supply is faulty. ● Off: No external power input is found.

4.3 Coffer Disk

The storage system has two kinds of coffer disks: built-in coffer disk and external coffer disk. Coffers disks are used to store three types of data: cache data requiring power failure protection, OceanStor OS system data, and system configuration information and logs.

Built-in Coffers Disk

Each controller houses two 800 GB U.2 NVMe SSD disks as coffer disks. The flushing speed of the U.2 NVMe SSD disk is 440 MB/s. [Table 4-24](#) describes capacity partitions of the built-in coffer disks.

Table 4-24 Capacity partitions of built-in coffer disks

Partition Name	Partition Size	Description
Cache dirty data partition	64 GB	Stores the cache dirty data that has not been written into a disk when the storage system is powered off.
OS system partition	10 GB	Stores the OceanStor OS system data.
CCDB partition	2 GB	Stores the user configuration information (such as user configuration data of remote replication, HyperMetro, and NAS data).
LogZone partition	4 GB	Stores system logs and run logs when the storage system is powered off and write through is enabled.

Partition Name	Partition Size	Description
DB partition	1 GB	Stores the user configuration information (such as information about the LUN capacity, ID, WWN, and Fibre Channel ports and iSCSI ports).

External Coffer Disk

The first four disks in the first disk enclosure are configured as coffer disks.

Appearance

Figure 4-37 shows the appearance of a coffer disk.

Figure 4-37 2.5-inch coffer disk

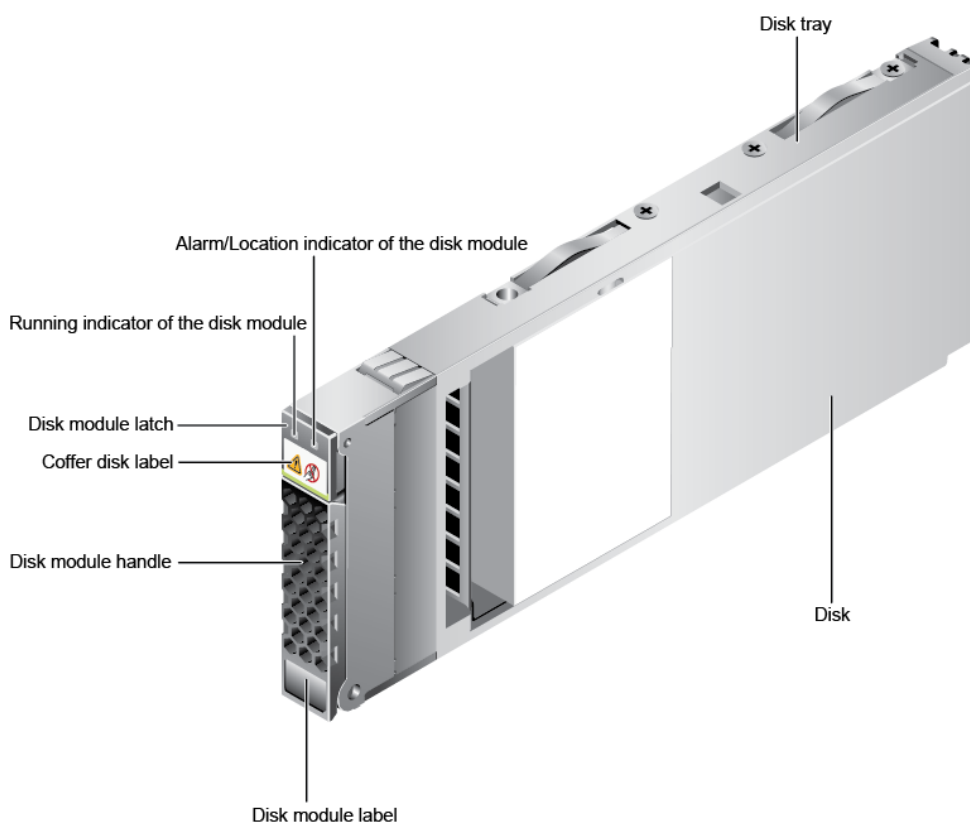

Positions

The first four disks in the first disk enclosure are planned as coffer disks, as shows in **Figure 4-38**.

Figure 4-38 Positions of external coffer disks



Capacity partitions: For the four disks, each spares 5 GB of space to form a RAID 1 group. The rest of the coffer disk space can be used to store service data. [Table 4-25](#) describes capacity partitions of external coffer disks.

Table 4-25 Capacity partitions of external coffer disks

Partition Name	Partition Size	Description
CCDB partition	2 GB	Stores the user configuration information (such as user configuration data of remote replication, HyperMetro, and NAS data). The four coffer disks are mirrors of each other for redundancy.
LogZone partition	2 GB	Stores system logs and run logs when the storage system is powered off and write through is enabled. The four coffer disks are mirrors of each other for redundancy.
DB partition	1 GB	Stores the user configuration information (such as information about the LUN capacity, ID, WWN, and Fibre Channel ports and iSCSI ports). The four coffer disks are mirrors of each other for redundancy.

4.4 Data Switch

With high bandwidth and low latency, data switches are the key to interconnection and communication among engines as well as control data flow and service flow exchange among controllers.

Data switches of the OceanStor 18500F V5/18800F V5 mission critical storage system are all monitored and managed by the service processor (SVP). Two data switches are configured only in system bay 1 and work in active-active mode that promotes I/O capability of the system.

Front View

[Figure 4-39](#) shows the front view of a data switch.

Figure 4-39 Front view of data switch

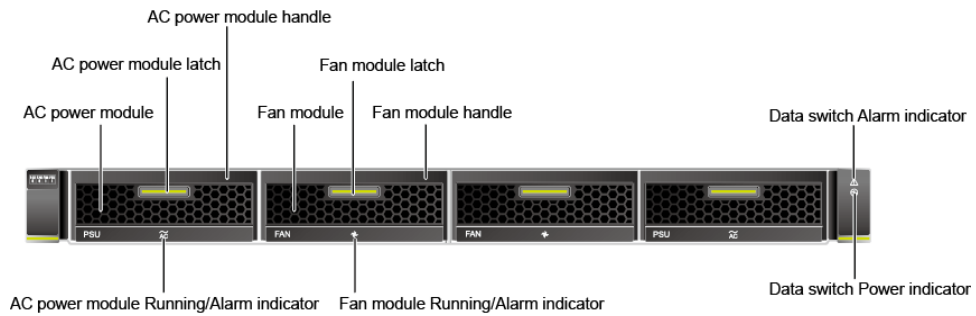

Table 4-26 describes indicators on the front panel of a powered data switch.

Table 4-26 Indicators on the front panel of a powered data switch

Indicator Name	Status and Description
Data switch Power indicator	<ul style="list-style-type: none"> ● Steady green: The data switch is working properly. ● Blinking green: The data switch is being powered on. ● Off: The data switch is powered off.
Fan Running/Alarm indicator	<ul style="list-style-type: none"> ● Steady green: The fan module is working properly. ● Steady red: The fan module is faulty. ● Off: The fan module is powered off.
Power Running/Alarm indicator	<ul style="list-style-type: none"> ● Steady green: The power module is working properly. ● Steady red: The power module is faulty. ● Off: The power module is powered off.
Data switch Alarm indicator	<ul style="list-style-type: none"> ● Steady red: The data switch is faulty. ● Off: The data switch is working properly.

Rear View

Figure 4-40 shows the rear view of a data switch.

Figure 4-40 Rear view of a data switch

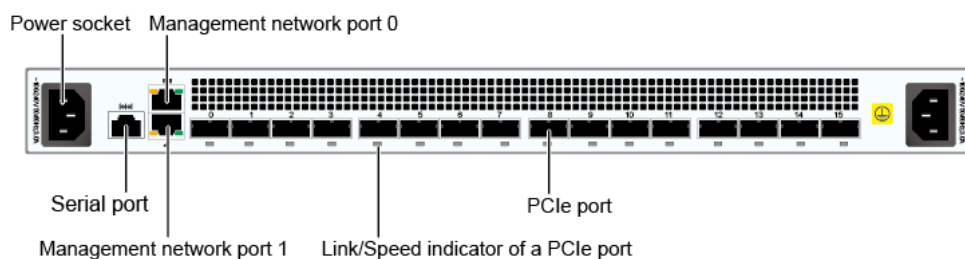

Table 4-27 describes indicators on the rear panel of a powered data switch.

Table 4-27 Indicators on the rear panel of a powered data switch

No.	Indicator Name	Status and Description
3	Link/Speed indicator of a PCIe port	<ul style="list-style-type: none"> ● Steady blue: The data transfer rate of the PCIe port is 5 Gbit/s. ● Steady green: The data transfer rate of the PCIe port is 2.5 Gbit/s. ● Steady red: The port is faulty. ● Off: The link of the port is down.

4.5 SVP

When the bay uses AC power, the service processor (SVP), working with the keyboard, video, and mouse (KVM), is the core component for managing, configuring, and maintaining the OceanStor 18500F V5/18800F V5 mission critical storage system. Maintenance and management tools are installed on the SVP and used for local or remote monitoring, management, configuration, and authentication.

Front Panel of the SVP

Figure 4-41 shows the front panel of the SVP.

Figure 4-41 Front Panel of the SVP

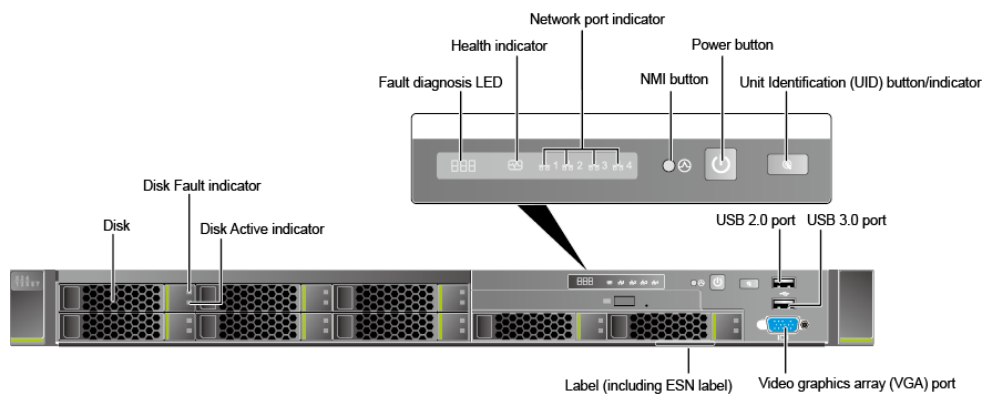

Table 4-28 describes the indicators and buttons on the SVP front panel.

Table 4-28 Indicators and buttons on the front panel

Meaning	Color	State Description
Fault diagnosis LED	None	<ul style="list-style-type: none"> ● ---: The SVP is operating properly. ● Error Code: A fault occurs in SVP hardware.

Meaning	Color	State Description
Power button/indicator	Yellow and green	<ul style="list-style-type: none"> ● Off: The SVP is not powered on. ● Blinking yellow: The system is being started. ● Steady yellow: The system is in the standby state. ● Steady green: The system is properly powered on. <p>NOTE You can hold down the power button for 6 seconds to power off the SVP.</p>
UID button/indicator	Blue	<p>The UID button/indicator helps identify and locate an SVP in a rack. You can turn on or off the UID indicator by manually pressing the UID button or remotely running a command on the CLI.</p> <ul style="list-style-type: none"> ● Steady on: The SVP is located. ● Off: The SVP is not located. ● You can hold down the UID button for 4 to 6 seconds to reset the system.
Health indicator	Red and green	<ul style="list-style-type: none"> ● Steady green: The SVP is operating properly. ● Blinking red at 1 Hz: A major alarm is generated. ● Blinking red at 5 Hz: A critical alarm is generated.
NMI button	None	<p>The NMI button triggers an SVP to generate a non-maskable interrupt. You can press this button or control it remotely through the WebUI.</p> <p>NOTICE</p> <ul style="list-style-type: none"> ● Click the NMI button only when the OS is abnormal. Do not click this button when the SVP is operating properly. ● Click the NMI button only for internal commissioning. Before clicking this button, ensure that the OS has the handler for NMI interrupt. Otherwise, the OS may crash. Exercise caution when clicking this button.
Disk Active indicator	Green	<ul style="list-style-type: none"> ● Off: The disk is not detected or is faulty. ● Blinking green: Data is being read from, written to the disk, or synchronized between disks. ● Steady green: The disk is inactive.

Meaning	Color	State Description
Disk Fault indicator	Yellow	<ul style="list-style-type: none"> ● Off: The disk is working properly or disks cannot be detected in the RAID group. ● Blinking yellow: The disk is being located, or the RAID is being reconstructed. ● Steady yellow: The disk is faulty, or hard disk members of the RAID array the hard disk is in are abnormal.
Network port Link status indicators	Green	<p>Each indicator shows the status of an Ethernet port on the network interface card (NIC).</p> <ul style="list-style-type: none"> ● Steady green: The port is properly connected. ● Off: The port is not in use. <p>NOTE If the NIC provides only two network ports, network port indicators 1 and 2 on the front panel are used.</p>

Rear View

Figure 4-42 show the rear view of the SVP.

Figure 4-42 Rear view of the SVP

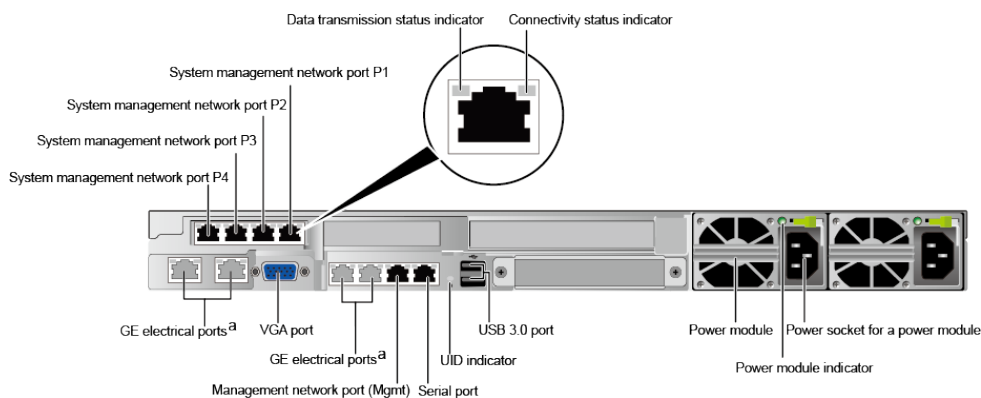

 **NOTE**

- On an SVP, system management network port P1 and system management network port P2 are bound by default. The two ports must always have the same IP address (for example, 192.168.0.136). It is advisable to connect system management network port P1 and system management network port P2 to the management network, for providing link redundancy and improving network reliability. Two links work in active-backup mode (mode 1). When the active link is faulty, the system automatically switches services to the backup link.
- System management networks port P3 and P4 on the SVP can be used for storage system connection.
- A serial port connects to the SMS modem only.
- USB ports connect to the status indicator on the front door using USB cables. When the system in the bay has major or critical alarms, the status indicator will be steady red.
- a: This port is reserved and does not have any function. Do not connect cables here.

Table 4-29 describes the indicators on the SVP rear panel.

Table 4-29 Indicators on the rear panel

Indicator	Color	State
Data transmission status indicator	Yellow	<ul style="list-style-type: none"> ● Off: No data is being transmitted. ● Blinking: Data is being transmitted.
Connectivity status indicator	Green	<ul style="list-style-type: none"> ● Steady green: The port is properly connected. ● Off: The port is not in use.
Unit Identification (UID) indicator	Blue	<p>The UID button/indicator helps identify and locate an SVP in a rack. You can turn on or off the UID indicator by manually pressing the UID button or remotely running a command on the CLI.</p> <ul style="list-style-type: none"> ● Steady on: The SVP is located. ● Off: The SVP is not located. ● You can hold down the UID button for 4 to 6 seconds to reset the system.
Power module indicator	Green	<ul style="list-style-type: none"> ● Steady green: Both the active output and the standby output are normal. ● Off: There is no AC power input; the input overvoltage or undervoltage occurs and the power module is not detected; the power module is abnormal.

4.6 (Optional) Quorum Server

For HyperMetro, if the heartbeats between two storage arrays are interrupted, the quorum server decides which storage array continues providing services, thereby greatly improving host service continuity.

Front Panel of the Quorum Server

Figure 4-43 shows the front panel of the quorum server.

Figure 4-43 Front panel of the quorum server

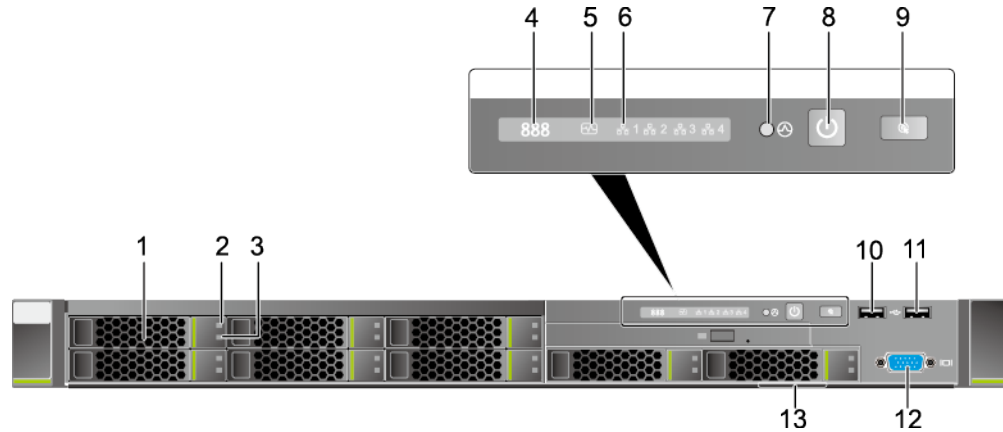

1	Disk	2	Disk Fault indicator
3	Disk Active indicator	4	Fault diagnosis LED
5	Health indicator	6	Network port indicator
7	NMI button	8	Power button/indicator
9	Unit Identification (UID) button/indicator	10	USB 2.0 port
11	USB 2.0 port	12	Video graphics array (VGA) port
13	Label (including ESN label)		

Table 4-30 describes the indicators and buttons on the quorum server front panel.

Table 4-30 Indicators and buttons on the front panel

Number	Meaning	Color	State Description
4	Fault diagnosis LED	None	<ul style="list-style-type: none"> ● ---: The quorum server is operating properly. ● Error Code: A fault occurs in quorum server hardware.

Number	Meaning	Color	State Description
8	Power button/ indicator	Yellow and green	<ul style="list-style-type: none"> ● Off: The quorum server is not powered on. ● Blinking yellow: The system is being started. ● Steady yellow: The system is in the standby state. ● Steady green: The system is properly powered on. <p>NOTE You can hold down the power button for 6 seconds to power off the quorum server.</p>
9	UID button/ indicator	Blue	<p>The UID button/indicator helps identify and locate an quorum server in a rack. You can turn on or off the UID indicator by manually pressing the UID button or remotely running a command on the CLI.</p> <ul style="list-style-type: none"> ● Steady on: The quorum server is located. ● Off: The quorum server is not located. ● You can hold down the UID button for 4 to 6 seconds to reset the system.
5	Health indicator	Red and green	<ul style="list-style-type: none"> ● Steady green: The quorum server is operating properly. ● Blinking red at 1 Hz: A major alarm is generated. ● Blinking red at 5 Hz: A critical alarm is generated.

Number	Meaning	Color	State Description
7	NMI button	None	<p>The NMI button triggers an quorum server to generate a non-maskable interrupt. You can press this button or control it remotely through the WebUI.</p> <p>NOTICE</p> <ul style="list-style-type: none"> ● Click the NMI button only when the OS is abnormal. Do not click this button when the quorum server is operating properly. ● Click the NMI button only for internal commissioning. Before clicking this button, ensure that the OS has the handler for NMI interrupt. Otherwise, the OS may crash. Exercise caution when clicking this button.
3	Disk Active indicator	Green	<ul style="list-style-type: none"> ● Off: The disk is not detected or is faulty. ● Blinking green: Data is being read from, written to the disk, or synchronized between disks. ● Steady green: The disk is inactive.
2	Disk Fault indicator	Yellow	<ul style="list-style-type: none"> ● Off: The disk is working properly. ● Blinking yellow: The disk is being located, or the RAID is being reconstructed. ● Steady yellow: The disk is faulty, or hard disk members of the RAID array the hard disk is in are abnormal.
6	Network port Link status indicators	Green	<p>Each indicator shows the status of an Ethernet port on the network interface card (NIC).</p> <ul style="list-style-type: none"> ● Steady green: The port is properly connected. ● Off: The port is not in use. <p>NOTE</p> <p>If the NIC provides only two network ports, network port indicators 1 and 2 on the front panel are used.</p>

Rear View of the Quorum Server

Figure 4-44 show the rear view of the quorum server.

Figure 4-44 Rear view of the quorum server

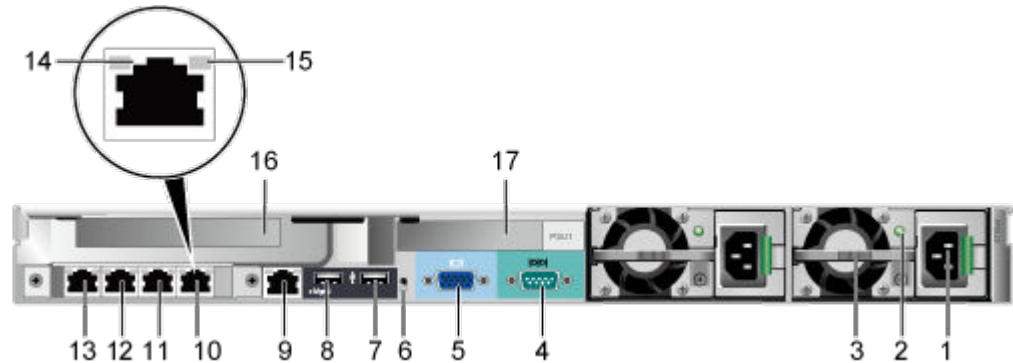

- | | | | |
|----|-----------------------------------|----|------------------------------------|
| 1 | Power socket for a power module | 2 | Power module indicator |
| 3 | Power module | 4 | Serial port |
| 5 | VGA port | 6 | UID indicator |
| 7 | USB 3.0 port | 8 | USB 3.0 port |
| 9 | Management network port of BMC | 10 | Management network port (Mgmt) |
| 11 | System management network port P3 | 12 | System management network port P2 |
| 13 | System management network port P1 | 14 | Data transmission status indicator |
| 15 | Connectivity status indicator | 16 | Full-height PCIe slot |

NOTE

This slot is reserved and does not install PCIe here.

- | | |
|----|-----------------------|
| 17 | Half-height PCIe slot |
|----|-----------------------|

NOTE

The default IP addresses of management network port (Mgmt) on quorum server is 192.168.128.200, the default subnet mask is 255.255.255.0.

Table 4-31 describes the indicators on the quorum server rear panel.

Table 4-31 Indicators on the rear panel

Number	Indicator	Color	State
14	Data transmission status indicator	Yellow	<ul style="list-style-type: none"> ● Off: No data is being transmitted. ● Blinking: Data is being transmitted.
15	Connectivity status indicator	Green	<ul style="list-style-type: none"> ● Steady green: The port is properly connected. ● Off: The port is not in use.

Number	Indicator	Color	State
6	Unit Identification (UID) indicator	Blue	<p>The UID button/indicator helps identify and locate an quorum server in a rack. You can turn on or off the UID indicator by manually pressing the UID button or remotely running a command on the CLI.</p> <ul style="list-style-type: none"> ● Steady on: The quorum server is located. ● Off: The quorum server is not located. ● You can hold down the UID button for 4 to 6 seconds to reset the system.
2	Power module indicator	Green	<ul style="list-style-type: none"> ● Steady green: Both the active output and the standby output are normal. ● Off: There is no AC power input; the input overvoltage or undervoltage occurs and the power module is not detected; the power module is abnormal.

4.7 Device Cables

Device cables used in the storage system include power cables, ground cables, and signal cables. This section shows these cables and describes their functions and specifications.

NOTE

The cable specifications vary according to the installation site. This section uses only one type of specifications for each device cable type as an example.

4.7.1 Power Cable

The power cable is PDU (Power Distribution Unit) power cable. The power cable transfers power for the device inside the cabinet. One end of the power cable is inserted to the socket on the engine or a disk enclosure, and the other end connects to the PDU.

AC Power

Each AC power module of an enclosure has a PDU power cable configured.

Figure 4-45 shows a PDU power cable.

Figure 4-45 PDU power cable



4.7.2 Ground Cable

Ground cables ground the engine and disk enclosures to ensure safe operation of the storage system.

Figure 4-46 shows a ground cable.

Figure 4-46 Ground cable



4.7.3 Network Cable

A network cable connects to a GE electrical port or the management network port in the storage system.

In the storage system, a network cable is used to:

- Connect the engine to an application server
 - Direct-connection networking
One end of the network cable is connected to the GE electrical port of the engine and the other end to the NIC port of the application server.
 - GE switch networking
One end of a network cable is connected to the GE electrical port of the engine and the other end to a port of the Ethernet switch. One end of another network cable is connected to another port of the Ethernet switch and the other end to the NIC port of the application server.
- Connect the engine to the SVP
One end of the network cable is connected to the management network port of the engine and the other end to the system management network port of the SVP.
- Connect the SVP to the maintenance terminal

One end of the network cable is connected to the system management network port of the SVP and the other end to the NIC port of the maintenance terminal.

Figure 4-47 shows a network cable.

Figure 4-47 Network cable



4.7.4 Serial Cable

A serial cable is used to connect the serial port of the engine to the serial port of the maintenance terminal.

One end of the serial cable is an RJ-45 connector, and the other end is a DB-9 connector. The RJ-45 connector of the serial cable connects to the serial port of the engine and the DB-9 connector connects to the serial port of the maintenance terminal.

Figure 4-48 shows a serial cable.

Figure 4-48 Serial cable



4.7.5 Mini SAS HD Cables

Mini SAS HD cables are used to connect expansion ports. Mini SAS HD cables are divided into mini SAS HD electrical cables and mini SAS HD optical cables.

4.7.5.1 Mini SAS HD Electrical Cables

Mini SAS HD electrical cables are used to connect a controller enclosure to a disk enclosure or connect two disk enclosures.

Figure 4-49 shows the appearance of a mini SAS HD electrical cable.

Figure 4-49 Mini SAS HD electrical cable



4.7.5.2 Mini SAS HD Optical Cables

Mini SAS HD optical cables are used to connect a controller enclosure to a disk enclosure or connect two disk enclosures.

Figure 4-50 shows the appearance of a mini SAS HD optical cable.

Figure 4-50 Mini SAS HD optical cable



 **NOTE**

The optical connector of a mini SAS HD optical cable has a built-in O/E conversion module and provides electrical ports.

4.7.6 Optical Fiber

The storage system communicates with Fibre Channel switches through optical fibers. One end of the optical fiber connects to the Fibre Channel host bus adapter (HBA), and the other end connects to the Fibre Channel switch or the application server. The two ends of the optical fiber are LC connectors.

Figure 4-51 shows the appearance of an optical fiber.

 **NOTE**

When connecting cables, select proper cables according to site requirements and label information.

Figure 4-51 Optical fiber



4.7.7 AOC Cable

An active optical cable (AOC) connects a PCIe port on a controller to a data switch.

One end of an AOC cable connects to a PCIe port on a controller of an engine, and the other end connects to a data switch.

Figure 4-52 shows an AOC cable.

Figure 4-52 AOC cable



4.7.8 FDR Cables

Fourteen data rate (FDR) cables are used for 56 Gbit/s IB interface module.

Figure 4-53 shows the appearance of an FDR cable.

Figure 4-53 FDR cable



4.7.9 MPO-4*DLC Fiber

MPO-4*DLC fiber is used for 8 Gbit/s Fiber Channel interface module (eight ports) and 16 Gbit/s Fiber Channel interface module (eight ports).

Figure 4-54 shows the appearance of the MPO-4*DLC fiber.

Figure 4-54 MPO-4*DLC fiber



5 Software Architecture

The OceanStor 18000F V5 series software manages storage devices and stored data, and assists application servers in data operations.

The software suite provided by the OceanStor 18000F V5 series consists of software running on a storage system, software running on the service processor (SVP), and software running on an application server. These three types of software interwork with each other to deliver storage, backup, and disaster recovery services in a smart, efficient, and economical manner.

Figure 5-1 shows the software architecture.

Figure 5-1 Software architecture of the OceanStor 18500F V5 and 18800F V5 mission critical storage system

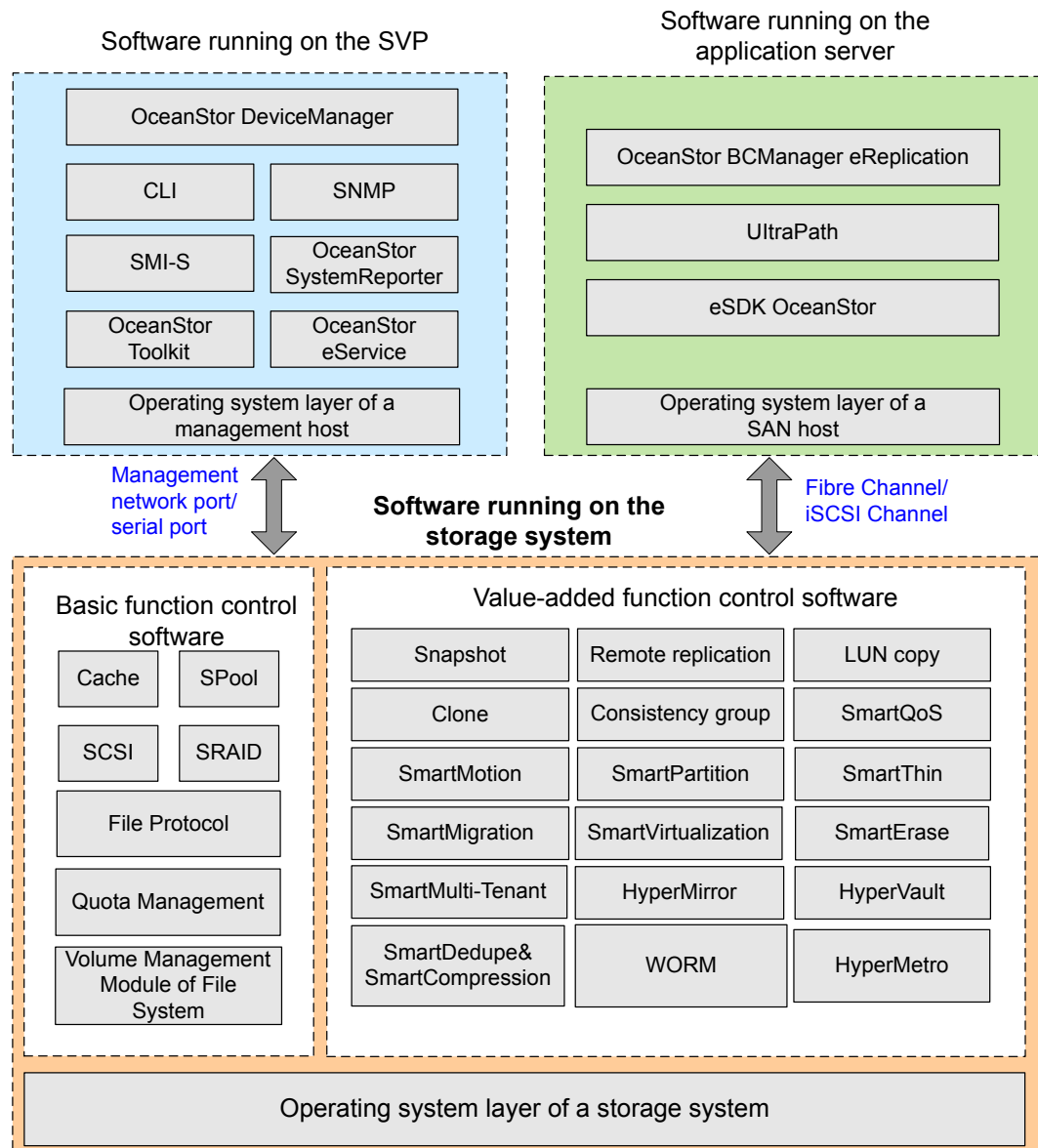

Table 5-1 describes the software running on a storage system. The dedicated OceanStor Operating System (OS) manages storage system hardware and supports the running of storage service software. The basic function control software provides basic data storage and access functions. The value-added function control software provides advanced functions such as backup, disaster recovery, and performance tuning.

Table 5-1 Software on a storage system

Software Set	Name	Function
Storage system operating system	-	Manages storage system hardware and supports the running of storage service software.
Basic function control software	SCSI software module	The software handles protocols at the Transport Layer of host interface protocols and manages status of SCSI commands. Also, it dispatches, resolves, and processes SCSI commands.
	Cache software module	The software converts a high-speed and small-capacity memory to a buffer memory of low-speed and large-capacity disks for tiered storage and improved system performance. Its major functions include data caching, delayed writes, and prefetch.
	SRAID software module	Uses data stripping and redundancy to provide high performance, large capacity, and high reliability for data storage. A wide range of RAID levels are provided for diversified data reliability and access performance.
	SPool software module	Logically combines disks from different disk enclosures into a disk domain, in which storage pools are created to provide storage resources for services.
	File protocol module	Provides file system sharing and backup functions. It supports CIFS, NFS, HTTP, and FTP file sharing protocols and NDMP backup protocol.
	Quota management module	Provides quota management for file system sharing. A shared file system allows you to specify the maximum storage capacity available to a specific directory.
	Volume management module of file system	Implements virtualized management based on volumes.
	Value-added function control software	HyperSnap software module

Software Set	Name	Function
	HyperReplication software module	Provides the remote replication function. Remote replication creates an available data duplicate of a local storage system almost in real time on a storage system that resides in a different region. The duplicate is instantly available without data restore operations, protecting service continuity and data availability to the maximum.
	HyperCopy software module	Provides the LUN copy function. A LUN copy copies the source LUN data onto the target LUN, addressing the requirements of tiered storage, application upgrade, and remote backup.
	HyperClone software module	Provides the clone function. Clone generates a full data copy of the source data in the local storage system.
	SmartThin software module	Provides the SmartThin function. SmartThin allocates storage space on demand. Within a specified quota of storage space, the OceanStor 18000F V5 series provides storage space based on demands of applications to save storage resources.
	SmartQoS software module	Provides the SmartQoS function. SmartQoS controls the storage performance of LUNs or file systems, and prioritizes the quality of service (QoS) of critical applications.
	SmartMotion software module	Provides the SmartMotion function. By analyzing services, SmartMotion evenly distributes data in the same type of medium for dynamically balanced capacity and performance.
	SmartPartition software module	Provides the SmartPartition function. SmartPartition allocates the cache resources from storage system engines on demand to improve QoS for mission-critical applications and high-level users.
	SmartMigration software module	Provides the SmartMigration function. SmartMigration migrates services on a source LUN transparently to a target LUN without interrupting host services. After the migration, the target LUN can replace the source LUN to carry the services.

Software Set	Name	Function
	SmartVirtualization software module	Provides the SmartVirtualization function. SmartVirtualization enables a local storage system to centrally manage storage resources of third-party storage systems, simplifying storage system management and reducing maintenance costs.
	SmartErase software module	Provides the SmartErase function. SmartErase erases unnecessary data on a specified LUN several times so that the data on the LUN cannot be recovered in case of leakage.
	SmartMulti-Tenant software module	Provides the SmartMulti-Tenant function. SmartMulti-Tenant enables a storage system to provide different tenants with shared storage resources and to separate tenant access and management.
	HyperMirror module	Provides the HyperMirror function. HyperMirror backs up data in real time. If the source data becomes unavailable, applications can automatically use the data copy, ensuring high data security and application continuity.
	SmartDedupe&SmartCompression software module	Provides the SmartDedupe&SmartCompression function. SmartDedupe analyzes and deletes redundant data in a storage system while SmartCompression significantly releases storage space occupied by data.
	WORM software module	Implements WORM to set critical data to read-only state, preventing unauthorized data change and deletion during a specified period of time.
	HyperMetro software module	Provides the HyperMetro function of SAN and NAS. HyperMetro enables real-time data synchronization and access between two storage systems, improving resource utilization. When data access fails, HyperMetro implements seamless service switchover, ensuring data security and service continuity.
	HyperVault software module	Provides the HyperVault function. HyperVault enables storage systems to protect their data.

Table 5-2 describes the software running on the SVP. Manages and maintains the storage system. The software includes OceanStor DeviceManager, command-line interface (CLI), simple network management protocol (SNMP), storage management initiative-specification (SMI-S), OceanStor Toolkit, OceanStor eService and OceanStor SystemReporter.

Table 5-2 Software on the SVP

Name	Function
OceanStor DeviceManager	The OceanStor DeviceManager is the integrated storage management platform developed by Huawei. The OceanStor DeviceManager provides easy configuration, management, and maintenance of storage devices.
SNMP ^{ab}	The storage system supports SNMP-based management and configuration. Users can manage and configure the storage system through third-party software that supports SNMP. A variety of network management software supports SNMP. Users can choose the software based on their requirements.
CLI ^c	The storage system supports CLI-based management and configuration. Third-party terminals (using the SSH protocol) can also be used to log in to and use the CLI of the OceanStor 18500F V5 and 18800F V5 mission critical storage system.
SMI-S	<p>The storage system supports SMI-S-based management and configuration. Users can manage and configure the storage system through third-party software that supports SMI-S. A variety of network management software supports SMI-S. Users can choose the software based on their requirements.</p> <p>To obtain interface introduction and configuration methods, please refer to <i>eSDK Storage V100R005C30 SMI-S Provider Quick Guide</i> and <i>eSDK Storage V100R005C30 SMI-S Provider Product Description</i>, which can be downloaded on the Huawei Mission Critical Technical Support Website.</p>
OceanStor Toolkit	OceanStor Toolkit helps service engineers and O&M engineers deploy, maintain, and upgrade devices.
OceanStor eService	OceanStor eService is a piece of remote maintenance and management software used for device monitoring, alarm reporting, and device inspection.
OceanStor SystemReporter	OceanStor SystemReporter is a dedicated performance and capacity report analysis tool for the storage system.
<p>a: Simple Network Management Protocol</p> <p>b: The supported character encoding is UTF-8.</p> <p>c: command-line interface</p>	

 **NOTICE**

The SVP carries the delivery-attached management software and maintenance software that are critical components of storage systems. To prevent compatibility issues and function failures, do not install third-party software (such as antivirus software and packet capturing tools) and uninstall the built-in software of the SVP. Otherwise, third-party software installation and built-in software uninstallation can result in management failures of storage systems and affect service stability and reliability. Huawei is not responsible for any system faults caused by forbidden installation and uninstallation actions.

Table 5-3 describes the software running on an application server. Includes the BCManager eReplication, UltraPath, and eSDK OceanStor. These pieces of software enable communication and collaboration between application servers and storage systems.

Table 5-3 Software on an application server

Name	Function
BCManager eReplication	The BCManager eReplication provides data backup and disaster recovery for application servers by working with related value-added features (synchronous/asynchronous remote replication, snapshot, LUN copy, clone, HyperMetro and HyperVault). It centrally manages the requirements for data backup and disaster recovery between storage systems and application servers.
UltraPath	The UltraPath is a storage system driver installed on application servers. When multiple data channels are set up between an application server and a storage system, the UltraPath selects an optimal channel for the application server to access the storage system. Therefore, UltraPath is an easy and efficient path management solution for proven data transmission reliability and high path security.
eSDK OceanStor	eSDK OceanStor is a Huawei-developed integration platform for storage devices. It has open capabilities and provides standard interfaces and preinstalled plug-ins. The plug-ins and providers of eSDK OceanStor enable the storage system to interconnect with vCenter and System Center so that customers can use their existing network management systems to manage Huawei's storage devices.

VM-based SVP Architecture

To ensure secure and stable operating of a storage system, the SVP employs a VM-based architecture. The SVP consists of a host, Windows VM, and Linux VM.

- The host runs Huawei Linux operating system EulerOS, and Windows and Linux VMs are deployed on the host.
- The Windows VM employs the Windows Server 2012 operating system to provide a graphical user interface (GUI). You can access the Windows VM remotely or using the KVM.

- The Linux VM employs Huawei Linux operating system EulerOS to provide a stable and open platform for management software. You can access the Linux VM using SSH and HTTPS.

Figure 5-2 shows the SVP software architecture.

Figure 5-2 SVP software architecture

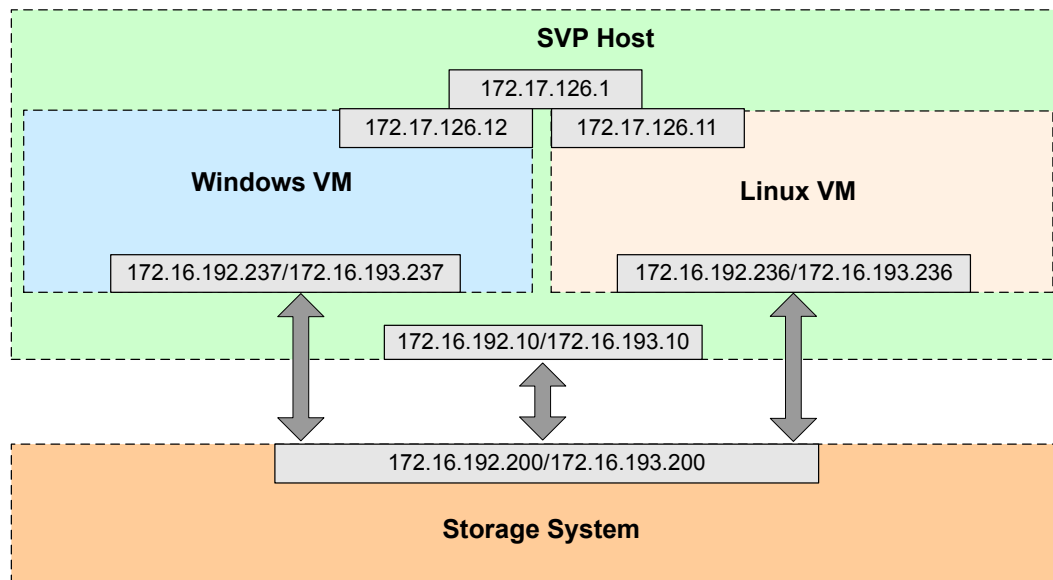

The host, Windows VM, and Linux VM use internal IP addresses to communicate with each other or with the storage system.

- Communication between the host and VMs:
 - IP address of the host: 172.17.126.1
 - IP address of the Windows VM: 172.17.126.12
 - IP address of the Linux VM: 172.17.126.11
- Communication between the host and the storage system:
 - IP addresses (physical IP addresses) of the host: 172.16.192.10 and 172.16.193.10
 - IP addresses of the storage system: 172.16.192.200 and 172.16.193.200
- Communication between the VMs and the storage system:
 - IP addresses of the Windows VM: 172.16.192.237 and 172.16.193.237
 - IP addresses of the Linux VM: 172.16.192.236 and 172.16.193.236
 - IP addresses of the storage system: 172.16.192.200 and 172.16.193.200

6 Product Specifications

About This Chapter

This chapter describes product specifications of the storage system: hardware specifications, and software specifications.

6.1 Hardware Specifications

Hardware specifications cover the hardware configuration, port specifications, disk specifications, dimensions, weight, electrical specifications, and reliability specifications.

6.2 Software Specifications

Software specifications cover the basic specifications, feature specifications, supported operating systems, and license control.

6.1 Hardware Specifications

Hardware specifications cover the hardware configuration, port specifications, disk specifications, dimensions, weight, electrical specifications, and reliability specifications.

Table 6-1 describes the hardware specification categories to help you quickly find out the specification information you need.

Table 6-1 Description of hardware specification categories

Category	Description
Hardware configuration	Describes the configuration of major hardware components, such as processors, memory capacity, hard disks, and ports.
Port specifications	Describes the port specifications, such as the maximum number of ports provided by each type of interface module and the maximum number of interface modules supported by each engine.
Disk specifications	Describes the dimensions, rotational speed, capacity, and weight of each type of disks.

Category	Description
Dimensions and weight	Describes the dimensions and weight of engine and disk enclosures.
Electrical specifications	Describes the electrical specifications of engine and disk enclosures.
Reliability specifications	Describes the reliability specifications of the OceanStor 18000 V3 series.

Hardware Configuration

Table 6-2 Hardware configuration

Item	OceanStor 18500F V5	OceanStor 18800F V5
Processors per controller	2 x 14-core processor	2 x 20-core processor
Memory size of a controller	<ul style="list-style-type: none"> ● 256 GB ● 512 GB ● 1 TB 	<ul style="list-style-type: none"> ● 512 GB ● 1 TB
Maximum number of controllers per engine	4	
Maximum number of engines	4	
Maximum number of disks	2400	3200
Engine configuration	6 U engine without disks	
Type of supported disk enclosures	2 U SAS disk enclosure with 25 x 2.5-inch disks	
Maximum number of expansion disk enclosures	2 U SAS disk enclosure: 96	2 U SAS disk enclosure: 128
Maximum number of disk enclosures connected to back-end channels (ports)	A maximum of Two SAS disk enclosures can be connected to a pair of SAS ports. One is recommended.	
Supported disk types	SSD	

Item	OceanStor 18500F V5	OceanStor 18800F V5
Types of hot-swappable front-end host interface modules	<ul style="list-style-type: none"> ● 8 Gbit/s Fibre Channel ● GE ● 10 Gbit/s FCoE ● 10GE (electrical) ● 56 Gbit/s (4 x 14 Gbit/s) IB ● SmartIO ● 16 Gbit/s Fibre Channel 	<ul style="list-style-type: none"> ● 8 Gbit/s Fibre Channel ● GE ● 10Gbit/s FCoE ● 10GE(electrical) ● 56Gbit/s(4 x 14 Gbit/s) IB ● SmartIO
Maximum number of front-end host ports per controller	<ul style="list-style-type: none"> ● 8 Gbit/s Fibre Channel: 24 (2 x 4-port 8 Gbit/s Fibre Channel module and 2 x 8-port 8 Gbit/s Fibre Channel module) ● GE: 16 ● 10 Gbit/s FCoE (VN2VF): 16 ● 10 Gbit/s FCoE (VN2VN): 8 ● 10GE (electrical): 16 ● 56 Gbit/s (4 x 14 Gbit) IB: 8 ● 10GE (optical port): 16 (SmartIO interface module equipped with a 10GE optical module) ● 16 Gbit/s Fibre Channel: 24 (2 x 4-port 16 Gbit/s Fibre Channel interface modules + SmartIO interface modules equipped with 16 Gbit/s Fibre Channel modules) 	<ul style="list-style-type: none"> ● 8 Gbit/s Fibre Channel: 24 (2 x 4-port 8 Gbit/s Fibre Channel module and 2 x 8-port 8 Gbit/s Fibre Channel module) ● GE: 16 ● 10 Gbit/s FCoE (VN2VF): 16 ● 10 Gbit/s FCoE (VN2VN): 8 ● 10GE (electrical): 16 ● 56 Gbit/s (4 x 14 Gbit/s) InfiniBand: 8 ● 10GE (optical port): 16 (SmartIO interface module equipped with a 10GE optical module) ● 16 Gbit/s Fibre Channel: 16 (SmartIO interface module equipped with a 16 Gbit/s Fibre Channel optical module)
Types of hot-swappable back-end disk interface modules	4 x 12 Gbit/s SAS (SAS shared expansion module)	
Maximum number of back-end ports per engine	48	
Length of expansion SAS cables	<ul style="list-style-type: none"> ● Electrical cables: 1 m, 3 m, and 5 m ● Optical cable: 15 m 	
Redundancy degree of main components	<ul style="list-style-type: none"> ● BBU: 3+1 ● Power modules: 2 x (1+1) ● Fans: 1+1 ● Management modules: 1+1 	

Port Specifications

Table 6-3 Port specifications

Maximum Number of Ports Per Interface Module	OceanStor 18500F V5	OceanStor 18800F V5
4-port 8 Gbit/s Fibre Channel interface module	Four ports for each front-end module	
8-port 8 Gbit/s Fibre Channel interface module	Eight ports for each front-end module	
GE electrical interface module	Four ports for each front-end module	
10GE electrical interface module	Four ports for each front-end module	
2-port 10 Gbit/s FCoE interface module	Two ports for each front-end module	
56 Gbit/s (4 x 14 Gbit/s) IB interface port	Two ports for each front-end module (The module is used for SAN services only and cannot be used for NAS services. It supports electrical ports only.)	
SmartIO interface module	Four ports for each front-end module ^a	
8-port 16 Gbit/s Fibre Channel interface module	Eight ports for each front-end module	-
SAS shared I/O module	Twelve ports for each back-end module	
PCIe interface module	Two ports for each data switch interface module	
<p>a: Each front-end module has four ports. The port types can be 8 Gbit/s Fibre Channel, 10 Gbit/s FCoE (VN2VF), 16 Gbit/s Fibre Channel, and 10 Gbit/s Eth (optical port, which cannot be used as GE ports). Specifications for switch connection using cables: Cisco-1 m cable SFP-H10GB-CU1M, Cisco- 3 m cable SFP-H10GB-CU3M, connect switches Cisco5596, and Cisco 2232 to Cisco 5596, connect Cisco 2232 to Cisco 5548; Huawei-1 m cable.</p>		

Disk Specifications

Table 6-4 Disk specifications

Disk Type ^a	Dimensions	Rotational Speed	Weight	Capacity
SSD	2.5-inch	-	0.25 kg (0.55 lb)	<ul style="list-style-type: none"> ● 600 GB ● 960 GB^b ● 1.92 TB^b ● 3.84 TB^b ● 7.68 TB
<p>a: Solid state disks (SSDs) cannot be preserved long after being powered off. In power-off status, the standing time of SSDs that have no data cannot exceed 12 months and the standing time of SSDs that have data cannot exceed three months. Otherwise, SSDs may malfunction or data loss may occur.</p> <p>b: Encrypted disks are supported.</p>				

Dimensions and Weight

Table 6-5 Dimensions and weight (unpackaged)

Module	OceanStor 18500F V5	OceanStor 18800F V5
Full bay dimensions (system bay and disk bay)	Bay: <ul style="list-style-type: none"> ● D: 1232 mm (48.50 in.) ● W: 600 mm (23.62 in.) ● H: 2000 mm (78.74 in.) 	
Engine dimensions	<ul style="list-style-type: none"> ● D: 750 mm (29.13 in.) ● W: 447 mm (17.60 in.) ● H: 263.9 mm (10.39 in.) 	
Dimensions of a 2 U disk enclosure	<ul style="list-style-type: none"> ● D: 488 mm (19.21 in.) ● W: 447 mm (17.60 in.) ● H: 86.1 mm (3.39 in.) 	
Fully loaded weight (system bay)	682.8 kg (1505.57 lb)	
Fully loaded weight (disk bay)	540 kg (1190.7 lb)	

Electrical Specifications

Table 6-6 Electrical specifications

Item	OceanStor 18500F V5	OceanStor 18800F V5
System bay	<ul style="list-style-type: none"> ● Maximum: 8526 W 4 controllers with 4 TB memory, 4 x 12-port SAS interface module, 12 SmartIO interface module (16 Gbit/s Fibre Channel), 400 x 2.5-inch 1.92 TB SSD disk ● Typical: 5604 W ● Minimum: 3493 W 	<ul style="list-style-type: none"> ● Maximum: 8686 W 4 controllers with 4 TB memory, 4 x 12-port SAS interface module, 12 SmartIO interface module (16 Gbit/s Fibre Channel), 400 x 2.5-inch 1.92 TB SSD disk ● Typical: 5764 W ● Minimum: 3582 W
Disk bay	<ul style="list-style-type: none"> ● Maximum: 5160 W ● Typical: 3344 W ● Minimum: 2208 W 	
Power consumption of an engine (four controllers)	<ul style="list-style-type: none"> ● Maximum: 3117 W ● Typical: 2144 W ● Minimum: 1514 W 	<ul style="list-style-type: none"> ● Maximum: 3384 W ● Typical: 2553 W ● Minimum: 1698 W
Power consumption of a 2U disk enclosure	<ul style="list-style-type: none"> ● Maximum: 320 W ● Typical: 192 W ● Minimum: 113 W 	
AC power voltage, rated currency and socket type of a PDU	<ul style="list-style-type: none"> ● Single-phase AC 220 V: 200 V to 240 V, AC±10%, 32 A, IEC60309-32A (2P+G) ● Three-phase AC 380 V: 346 V to 415 V, AC±10%, 32 A, IEC60309-32A (3W+N+PE) ● High voltage DC 240 V: 240 V, DC±20%, 32 A, IEC60309-32A (2P+G) ● North America three-phase 208 V: 200 V to 240 V, AC ±10%, CS8365C (3W+PE) 	
Each BBU capacity	32 Wh	

Reliability Specifications

Table 6-7 Reliability specifications

Item	Value
Solution reliability	99.9999%

Item	Value
Mean Time Between Failures (MTBF)	1,200,000 hours
Mean Time To Repair (MTTR)	1 hour

6.2 Software Specifications

Software specifications cover the basic specifications, feature specifications, supported operating systems, and license control.

Table 6-8 describes the software specification categories to help you quickly find out the specification information you need.

Table 6-8 Description of software specification categories

Category	Description
Basic specifications	Describes the basic software specifications of the OceanStor storage system, including the maximum number of connected application servers, maximum number of LUNs, and maximum number of mapping views.
Feature specifications	Describes the feature specifications of the OceanStor storage system, including snapshot, remote replication, LUN copy, and clone.
Supported operating systems	Describes the operating systems supported by the OceanStor storage system.
License control	Describes whether software features of the OceanStor storage system are controlled by licenses.

Basic Specifications

Table 6-9 Basic specifications

Item	OceanStor 18500F V5	OceanStor 18800F V5
Maximum number of connected application servers	<ul style="list-style-type: none"> ● Fibre Channel: 65,535 ● iSCSI: 4096 	
Maximum number of hosts per host group	64	
Maximum number of LUNs ^a	65,536	

Item	OceanStor 18500F V5	OceanStor 18800F V5
Maximum number of LUN groups	8192	
Maximum number of PE LUNs	64	
Maximum number of VVol LUNs ^a	65,536	
Maximum number of mapping views	8191	
Maximum number of disk domains	128	
Maximum number of disks in a disk domain	2400 (Maximum number of disks per engine: 2000)	3200 (Maximum number of disks per engine: 2000)
RAID level	0, 1, 3, 5, 6, 10, 50	
Maximum number of storage pools	512	
Maximum number of LUNs in a storage pool	65,536	
Minimum capacity of a LUN	512 KB	
Maximum capacity of a LUN	256 TB	
Maximum number of file systems	<ul style="list-style-type: none"> ● The maximum number of clone file systems and file systems cannot exceed 8192. ● The maximum number of clone file systems, file systems, LUNs, and their writable snapshots cannot exceed 65536. 	
Minimum capacity of a file system	1 GB	
Maximum capacity of a file system	16 PB	
Maximum number of files per file system	2 billion	
Maximum capacity of a file	256 TB	
Maximum number of sub-directories per directory	30 million	
Maximum number of SMB shares	12,000	
Maximum number of NFS shares	10, 000	

Item	OceanStor 18500F V5	OceanStor 18800F V5
Maximum number of CIFS and NFS connections per controller	36,000	
Maximum number of FTP connections per controller	512	
Maximum number of HTTP connections per controller	512	
Maximum number of NDMP streams	32	
Maximum number of local users	4000	
Maximum number of local user groups	70,000	
Maximum number of users in a user group	250,000	
Maximum file path length	4096 bytes	
Maximum length of a single file name or directory name	256 bytes	
Maximum directory depth of a file system	256	
Maximum number of files that can be opened at a time on a controller	500,000	
Maximum number of logical ports per controller	256	
Maximum number of VLAN per controller	256	
a: Maximum total number of file systems, LUNs, and their writable snapshots, plus the number of PE LUNs and VVol LUNs.		

Feature Specifications

Table 6-10 Feature specification

Feature Name	Parameter	OceanStor 18500F V5	OceanStor 18800F V5
HyperSnap	Maximum number of LUN snapshots	32,768	

Feature Name	Parameter	OceanStor 18500F V5	OceanStor 18800F V5
	Maximum number of read-only snapshots in a file system	128,000	
	Maximum number of source LUNs	16,384	
	Maximum number of snapshots for a source LUN	1024	
	Maximum number of read-only snapshots for a source file system	2048	
	Maximum number of LUNs that can be batch activated	8192	
	Minimum interval of periodic snapshots for a file system	1 minute	
	Recovery time of a file system snapshot	< 10 seconds	
LUN Copy	Maximum number of LUN copies	1024	
	Maximum number of target LUNs for each source LUN	128	
LUN clone	Maximum number of primary LUNs	16,384	
	Maximum number of secondary LUNs	32,768	
	Maximum number of secondary LUNs supported by a primary LUN	16	
	Maximum number of consistent split pairs	8192	
File system clone	Maximum number of clone file systems	<ul style="list-style-type: none"> ● The maximum number of clone file systems and file systems cannot exceed 8192. ● The maximum number of clone file systems, file systems, LUNs, and their writable snapshots cannot exceed 65536. 	
	Maximum levels of cascading clones	8	

Feature Name	Parameter	OceanStor 18500F V5	OceanStor 18800F V5
HyperReplication	Maximum number of pairs in a remote replication (synchronous + asynchronous, LUN + file system) ^a	65,536 (remote replication for file system: 4096)	
	Maximum number of secondary LUNs in a pair	<ul style="list-style-type: none"> ● Synchronous: 1 ● Asynchronous: 2 	
	Maximum number of secondary file systems in a pair	Asynchronous: 1	
	Maximum number of connected remote storage devices	64	
	Maximum number of remote replication consistency groups (LUN)	512	
	Maximum number of pairs in a remote replication consistency group (LUN)	8192	
SmartThin	Maximum number of thin LUNs (same as the maximum number of thick LUNs)	65,536	
	Maximum capacity of a thin LUN (TB)	256	
	Conversion between thin and thick LUNs	Supported (Implemented through LUN migration)	
	Thin granularity	64 KB	
	Space reclamation	Supported	
SmartQoS	Maximum number of SmartQoS policies	4096	
	Maximum LUN quantity supported by a QoS policy	64	
	Number of priority levels	3	
SmartMotion	Relocation granularity	64 MB	
SmartPartition	Maximum cache partitions for every two controllers	8	
	Minimum size of a cache partition	256 MB	

Feature Name	Parameter	OceanStor 18500F V5	OceanStor 18800F V5
	Maximum size of a cache partition	40 GB	
SmartMigration	Maximum number of LUNs that can be simultaneously migrated by a controller	8	
	Maximum number of LUNs for which migration can be configured at a time	2048	
SmartErase	Maximum number of LUNs whose data can be simultaneously destructed by each controller	16	32
SmartMulti-tenancy	Maximum number of tenants	255	
	Maximum number of tenant administrators	512	
	Maximum number of tenant administrators for a tenant	32	
SmartVirtualization	Maximum number of external LUNs	8192	
	Maximum number of external storage arrays	256	
	Maximum number of paths for each external LUN	32	
	Maximum number of masqueraded LUNs	8192	
	Maximum number of links that connect to external arrays	8192	
	Maximum number of links that connect to external arrays on a single controller	2048	
HyperMirror	Maximum number of volume mirrors	512	
	Number of copies per volume mirror	2	
SmartQuota	Number of quota directory trees per file system	4096	
	User quota	4000	
	User group quota	70000	

Feature Name	Parameter	OceanStor 18500F V5	OceanStor 18800F V5
SmartCompression	Granularity of data block compression	<ul style="list-style-type: none"> ● File system: 8 KB/16 KB/32 KB/64 KB auto-adjust ● LUN: 4 KB/8 KB/16 KB/32 KB/64 KB auto-adjust 	
SmartDeduplicate	Granularity of data block deduplication (configurable)	4 KB/8 KB/16 KB/32 KB/64 KB auto-adjust	
NAS antivirus	Virus-scanning mode	CIFS share (scanning starts when files are closed)	
	Maximum number of antivirus servers	512	
	Maximum number of file systems that can be monitored	8192	
	Maximum number of virus scanning policies	1024	
	Maximum number of antivirus servers per vStore	32	
HyperMetro (SAN)	Maximum number of active-active domains	32 The number of NAS and SAN HyperMetro domains cannot exceed 32.	
	Maximum number of active-active LUN pairs in a consistency group	512	
	Maximum number of active-active pairs	4096	
	Maximum number of pairs in a consistency group	4096	
	Maximum number of pairs in an active-active domain	4096	
	Maximum number of physical links that connect to a controller	8	
	Maximum distance	< 300 km	
	Supported link types	8 Gbit/s Fibre Channel/16 Gbit/s Fibre Channel/10GE	
	Supported protocol type	iSCSI or Fibre Channel	
	Arbitration mode	Static priority mode Quorum server mode	

Feature Name	Parameter	OceanStor 18500F V5	OceanStor 18800F V5
HyperMetro (NAS)	Maximum number of active-active domains	2	The number of NAS and SAN HyperMetro domains cannot exceed 32.
	Maximum number of tenant pairs	255	
	Maximum number of file system pairs	2048	
	Maximum number of physical links that connect to a controller	8	
	Maximum distance	< 300 km	
	Supported link types	8 Gbit/s Fibre Channel/16 Gbit/s Fibre Channel/10GE	
	Supported protocol type	SMB3.0/NFSv3/NFSv4	
	Arbitration mode	Static priority mode Quorum server mode	
Quorum client	Maximum number of quorum servers that can be connected to an array	32	
	Maximum number of quorum servers that can be connected to a HyperMetro domain	2	
	Maximum number of IP addresses that can be added to a quorum server	2	
	Maximum number of links that can be connected from each controller of an array to the same quorum server	2	
HyperVault	Maximum number of backup pairs	1024	
	Maximum number of backup copies	8192	
	Backup speed	Fast, high, medium, low	
	Backup period	5 minutes to 1 month	
	Maximum number of backup policies per pair	Local backup policies: 4 Remote backup policies: 4	

Feature Name	Parameter	OceanStor 18500F V5	OceanStor 18800F V5
	Maximum number of backup copies per pair	Local backup copies: 256 Remote backup copies: 256	
a: Maximum total number of remote replication pairs (LUN/file system), HyperMetro pairs (SAN/NAS), and HyperVault pairs.			

Supported Operating Systems

Only the common operating systems supported by the OceanStor mission critical storage system are listed. For details, contact Huawei technical support engineers.

Table 6-11 Supported operating systems

Operating System	OceanStor 18500F V5	OceanStor 18800F V5
Windows	Mainstream Windows operating systems are supported, including but not limited to the following: <ul style="list-style-type: none"> ● Windows Server 2003 R2 Standard SP2 ● Windows Server 2003 R2 Datacenter SP2 ● Windows Server 2003 R2 Enterprise Edition SP2 ● Windows Server 2008 R2 Standard SP1 ● Windows Server 2008 R2 Datacenter SP1 ● Windows Server 2008 R2 Enterprise Edition SP1 ● Windows Server 2012 Standard ● Windows Server 2012 Datacenter ● Windows Server 2012 Essentials ● Windows Server 2012 Foundation X64 Edition 	
Linux	Mainstream Linux operating systems are supported, including but not limited to the following: <ul style="list-style-type: none"> ● SUSE Linux Enterprise Server 10 ● SUSE Linux Enterprise Server 11 ● Red Hat Enterprise Server AS 5 ● Red Hat Enterprise Server AS 6 	

Operating System	OceanStor 18500F V5	OceanStor 18800F V5
Other mainstream operating systems	<ul style="list-style-type: none"> ● HP-UX 11i v2 ● HP-UX 11i v3 ● AIX 6.1 ● AIX 7.1 ● Solaris 10 for Sparc ● Solaris 11 for Sparc ● VMware ESXi 4.1 ● VMware ESXi 5.0 ● Citrix XenServer 5.6 ● Citrix XenServer 6.0 ● MAC OS X 10.7 ● Others 	

License Control

The following table only describes whether functions are license-controlled. For support means or authorized capacity of the licenses, contact Huawei technical support engineers.

Table 6-12 License control

Function	Requiring License Control or Not
HyperSnap (Snapshot)	√ ^a
HyperClone (Clone)	√
HyperCopy (LUN Copy)	√
HyperReplication (Remote replication)	√ ^b
SmartQoS	√
SmartMotion	√
SmartThin	√
SmartPartition	√
SmartMigration	√
SmartErase	√
SmartMulti-Tenant	√
SmartVirtualization	√
HyperMirror	√

Function	Requiring License Control or Not
SmartCompression (for LUN&FS)	√
SmartDedupe (for LUN&FS)	√
SmartQuota	√
CIFS	√
NFS	√
WORM (HyperLock)	√
NDMP	√
HyperMetro (for LUN)	√
HyperMetro (for FS)	√
HyperVault	√
<p>a: HyperSnap for block and file services requires the same license. After purchasing and importing the license file for the HyperSnap feature, a user can create snapshots for both block and file services.</p> <p>b: HyperReplication for block and file services requires the same license. After purchasing and importing the license file for the HyperReplication feature, a user can create remote replications for both block and file services.</p>	

 **NOTE**

As the OceanStor SystemReporter and OceanStor UltraPath are not deployed on a storage system, you cannot check them on the license management page of the storage system. To view purchased features, you can obtain the product authorization certificate from your dealer, which shows the purchased features.

Interoperability and Host Connectivity

You can go to [OceanStor Interoperability Navigator](#) and select the components such as an operating system and multipathing software you want to check to obtain the compatibility information.

7 Environmental Requirements

About This Chapter

Environmental requirements cover the following aspects: temperature, humidity, particle contaminants, corrosive airborne contaminants, heat dissipation, and noise.

[7.1 Temperature and Humidity](#)

The requirements of the storage system on temperature and humidity vary depending on the altitude at which the storage systems reside.

[7.2 Vibration and Shock](#)

Vibration and shock requirements must be met so that storage systems can correctly work or be properly preserved.

[7.3 Particle Contaminants](#)

Particle contaminants and other negative environmental factors (such as abnormal temperature and humidity) may expose IT equipment to higher risks of corrosive failure. This section specifies the limitation on particle contaminants with an aim to avoid such risks.

[7.4 Corrosive Airborne Contaminants](#)

Corrosive airborne contaminants and other negative environmental factors (such as abnormal temperature and humidity) may expose IT equipment to higher risks of corrosive failure. This article specifies the limitation on corrosive airborne contaminants with an aim to avoid such risks.

[7.5 Heat Dissipation and Noise](#)

A storage system can run steadily for a long time with the heat dissipation system carried by its own fan modules. An external device needs to be used to take away the hot air discharged from a storage system, ensuring air circulation. When the ambient temperature is 25°C (77°F), the noise made by a storage system is 7.5 bels.

7.1 Temperature and Humidity

The requirements of the storage system on temperature and humidity vary depending on the altitude at which the storage systems reside.

Table 7-1 lists the requirements of the storage system on temperature and humidity.

Table 7-1 Requirements on ambient temperature and humidity

Parameter	Condition	Requirement
Temperature	Operating temperature	<ul style="list-style-type: none"> ● 5°C to 35°C (41°F to 95°F) when the altitude is below 1800 m (5905.51 ft) ● 5°C to 30°C (41°F to 86°F) when the altitude ranges from 1800 m to 3000 m (5905.51 ft to 9842.52 ft)
	Temperature variation in the operating environment	<ul style="list-style-type: none"> ● Operating: 20°C/h ● Storage and transportation: 30°C/h
	Non-operating temperature	-40°C to 60°C (-40°F to 140°F)
	Temperature variation in the non-operating environment	10°C/h (18°F /h)
	Storage temperature (during transportation and storage with packages)	-40°C to 60°C (-40°F to 140°F)
Humidity	Humidity	10% RH ^a to 90% RH
	Storage humidity	5% RH to 95% RH
	Non-operating humidity	5% RH to 95% RH
	Maximum humidity variation	25%/h
a: relative humidity (RH)		

7.2 Vibration and Shock

Vibration and shock requirements must be met so that storage systems can correctly work or be properly preserved.

Table 7-2 shows the vibration and shock requirements of storage systems.

Table 7-2 Vibration and shock requirements of storage systems

Parameter	Requirement
Operating variation (random vibration)	5 Hz to 10 Hz: +12 dB/Oct; 10 Hz to 50 Hz: 0.04 m ² /s ³ ; 50 Hz to 100 Hz: - 12 dB/Oct
Operating variation (sinusoidal vibration)	5 Hz to 9 Hz: 1.2 mm; 9 Hz to 200 Hz: 4 m/s ²
Operating shock	Peak acceleration: 30 m/s ² ; pulse duration: 11 ms

Parameter	Requirement
Non-operating vibration	Power spectrum density: 5 Hz to 30 Hz, 0.00052 g ² /Hz; 100 Hz to 500 Hz, 0.0001 g ² /Hz
Non-operating shock	8 g/15 ms (peak acceleration/pulse width)

7.3 Particle Contaminants

Particle contaminants and other negative environmental factors (such as abnormal temperature and humidity) may expose IT equipment to higher risks of corrosive failure. This section specifies the limitation on particle contaminants with an aim to avoid such risks.

The concentration level of particle contaminants in a data center shall meet the requirements listed in the white paper entitled *Gaseous and Particulate Contamination Guidelines for Data Centers published in 2011* by American Society of Heating Refrigerating and Air-conditioning Engineers (ASHRAE) Technical Committee (TC) 9.9.

ASHRAE, affiliated to International Organization for Standardization (ISO), is an international organization operated for the exclusive purpose of advancing the arts and sciences of heating, ventilation, air-conditioning, and refrigeration (HVAC & R). The *Gaseous and Particulate Contamination Guidelines for Data Centers* is widely accepted, which is prepared by the members of ASHRAE TC 9.9, AMD, Cisco, Cray, Dell, EMC, Hitachi, HP, IBM, Intel, Seagate, SGI, and Sun.

According to the Guidelines, particle contaminants in a data center shall reach the cleanliness of ISO 14664-1 Class 8:

- Each cubic meter contains not more than 3,520,000 particles that are equal to and greater than 0.5 μm.
- Each cubic meter contains not more than 832,000 particles that are equal to and greater than 1 μm.
- Each cubic meter contains not more than 29,300 particles that are equal to and greater than 5 μm.

It is recommended that you use an effective filter to process the air flowing into the data center and use a filtering system to periodically clean the air already in the data center.

ISO 14644-1, *Cleanrooms and Associated Controlled Environments - Part 1: Classification of Air Cleanliness*, is the primary global standard on air cleanliness classification. [Table 7-3](#) gives the air cleanliness classification by particle concentration.

Table 7-3 Air cleanliness classification by particle concentration

ISO Class	Maximum allowable concentrations (particles/m ³) for particles equal to and greater than the considered sizes shown below					
	≥ 0.1 μm	≥ 0.2 μm	≥ 0.3 μm	≥ 0.5 μm	≥ 1 μm	≥ 5 μm
Class 1	10	2	-	-	-	-
Class 2	100	24	10	4	-	-

ISO Class	Maximum allowable concentrations (particles/m ³) for particles equal to and greater than the considered sizes shown below					
	≥ 0.1 μm	≥ 0.2 μm	≥ 0.3 μm	≥ 0.5 μm	≥ 1 μm	≥ 5 μm
Class 3	1000	237	102	35	8	-
Class 4	10,000	2370	1020	352	83	-
Class 5	100,000	23,700	10,200	3520	832	29
Class 6	1,000,000	237,000	102,000	35,200	8320	293
Class 7	-	-	-	352,000	83,200	2930
Class 8	-	-	-	3,520,000	832,000	29,300
Class 9	-	-	-	-	8,320,000	293,000

7.4 Corrosive Airborne Contaminants

Corrosive airborne contaminants and other negative environmental factors (such as abnormal temperature and humidity) may expose IT equipment to higher risks of corrosive failure. This article specifies the limitation on corrosive airborne contaminants with an aim to avoid such risks.

Table 7-4 lists common corrosive airborne contaminants and their sources.

Table 7-4 Common corrosive airborne contaminants and their sources

Symbol	Sources
H ₂ S	Geothermal emissions, microbiological activities, fossil fuel processing, wood rot, and sewage treatment.
SO ₂ , SO ₃	Coal combustion, petroleum products, automobile emissions, ore smelting, and sulfuric acid manufacture.
S	Foundries, sulfur manufacture, and volcanoes.
HF	Fertilizer manufacture, aluminum manufacture, ceramics manufacture, steel manufacture, and electronics device manufacture.
NO _x	Automobile emissions, fossil fuel combustion, chemical industry
NH ₃	Microbiological activities, sewage, fertilizer manufacture, geothermal emissions, and refrigeration equipment.
C	Incomplete combustion (aerosol constituent), and foundry.
CO	Combustion, automobile emissions, microbiological activities, tree rot

Symbol	Sources
Cl ₂ , ClO ₂	Chlorine manufacture, aluminum manufacture, zinc manufacture, and refuse decomposition.
HCl	Automobile emissions, combustion, forest fire, oceanic processes, and polymer combustion.
HBr, HI	Automobile emissions.
O ₃	Atmospheric photochemical processes mainly involving nitrogen oxides and oxygenated hydrocarbons.
C _N H _N	Automobile emissions, animal waste, sewage, and tree rot.

The concentration level of corrosive airborne contaminants in a data center shall meet the requirements listed in the white paper entitled *Gaseous and Particulate Contamination Guidelines for Data Centers published in 2011* by American Society of Heating Refrigerating and Air-conditioning Engineers (ASHRAE) Technical Committee (TC) 9.9.

According to the Guidelines, corrosive airborne contaminants in a data center shall meet the following requirements:

- Copper corrosion rate
Less than 300 Å/month per ANSI/ISA-71.04-1985 severity level G1.
- Silver corrosion rate
Less than 200 Å/month.

 **NOTE**

Å, or angstrom, is a unit of length. One Å is equal to 1/10,000,000,000 meter.

According to ANSI/ISA-71.04-1985 Environmental Conditions for Process Measurement and Control Systems: Airborne Contaminants, the gaseous corrosivity levels are G1 (mild), G2 (moderate), G3 (harsh), and GX (severe), as described in [Table 7-5](#).

Table 7-5 Gaseous corrosivity levels per ANSI/ISA-71.04-1985

Severity Level	Copper Reactivity Level	Description
G1 (mild)	300 Å/month	An environment sufficiently well-controlled such that corrosion is not a factor in determining equipment reliability.
G2 (moderate)	300 Å/month to 1000 Å/month	An environment in which the effects of corrosion are measurable and may be a factor in determining equipment reliability.
G3 (harsh)	1000 Å/month to 2000 Å/month	An environment in which there is high probability that corrosive attack will occur.
GX (severe)	> 2000 Å/month	An environment in which only specially designed and packaged equipment would be expected to survive.

See [Table 7-6](#) for the requirements on the copper and silver corrosion rates.

Table 7-6 Concentration limitation on corrosive airborne contaminants in a data center

Group	Gas	Unit	Concentration
Group A	H ₂ S	ppb ^a	< 3
	SO ₂	ppb	< 10
	Cl ₂	ppb	< 1
	NO ₂	ppb	< 50
Group B	HF	ppb	< 1
	NH ₃	ppb	< 500
	O ₃	ppb	< 2
a: Parts per billion (ppb) is the number of units of mass of a contaminant per billion units of total mass.			

Group A and group B are common gas groups in a data center. Group A's or group B's concentration limitation values that correspond to copper reactivity level G1 are calculated based on the condition that relative humidity in a data center is lower than 50% and that the gases in the group interact with each other. A 10% of increase in the relative humidity will heighten the gaseous corrosivity level by 1.

Corrosion is not determined by a single factor, but by comprehensive environmental factors such as temperature, relative humidity, corrosive airborne contaminants, and ventilation. Any of the environmental factors may affect the gaseous corrosivity level. Therefore, the concentration limitation values specified in the previous table are for reference only.

7.5 Heat Dissipation and Noise

A storage system can run steadily for a long time with the heat dissipation system carried by its own fan modules. An external device needs to be used to take away the hot air discharged from a storage system, ensuring air circulation. When the ambient temperature is 25°C (77°F), the noise made by a storage system is 7.5 bels.

Heat Dissipation

Air is taken in a bay of the OceanStor storage systems from the bay's front panel and out of the bay from the ventilation holes on the bay's rear panel and cover. You are advised to separate cold air aisles from hot air aisles. Deploy a hot air collecting ceiling above the hot air aisles. In this way, hot air generated by the device is returned to the precision air conditioner. Therefore, hot air and cold air are separated. This deployment can increase cooling efficiency of the air conditioner and decrease power usage efficiency (PUE) of the data center.

 **NOTICE**

If the storage device is installed on the raised floor, deploy a ventilation floor in front of each bay. This deployment can maintain an even system temperature against device damage caused by overheated parts.

For better maintenance, ventilation, and heat dissipation, pay attention to the following when installing the storage system to the cabinet:

- To ensure smooth ventilation, the cabinet should be at least 100 cm (39.4 inches) away from the walls and at least 120 cm (47.28 inches) away from another cabinet (in front of or behind this one).
- To keep air convecting between the cabinet and the equipment room, no enclosed space is allowed in the cabinet. 1 U (44.45 mm, 1.75 inches) space should be left above and below each device.

Table 7-7 lists the heat dissipation and exhausted air volume made by the a storage system when the ambient temperature is 25°C (77°F).

Table 7-7 Heat dissipation parameters of a storage system

Parameter	OceanStor 18500F V5	OceanStor 18800F V5
Heat dissipation (system bay)	Power consumption x 3.41 BTU/H	
Heat dissipation (Disk bay)	Power consumption x 3.41 BTU/H	
Exhausted air volume (system bay)	<ul style="list-style-type: none"> ● Typical: 784 CFM ● Maximum: 2312 CFM 	
Exhausted air volume (disk bay)	<ul style="list-style-type: none"> ● Typical: 608 CFM ● Maximum: 1872 CFM 	

Noise

The disks and fans make noise when they are working, and fans are the major noise source. The work intensity of fans is associated with the temperature. A higher temperature leads to greater work intensity of fans. Greater work intensity leads to stronger noise. Therefore, the noise made by a storage system is associated with the ambient temperature.

Table 7-8 lists the noise made by the a storage system when the ambient temperature is 25°C (77°F).

Table 7-8 Noise parameter of a storage system

Parameter	Value
Noise	73.4 dB(A)

8 Standards Compliance

The chapter describes the protocol standards, the safety specifications and electromagnetic compatibility (EMC) standards, the industry standards that the storage system complies with.

Protocol Standards

Table 8-1 lists the protocol standards that the storage system complies with.

Table 8-1 Protocol standards

Name	Standard No.
SCSI system	FC-PH: ANSI X3.230
	FC-PH2: ANSI X3.297
	SCSI-FCP: ANSI X.269
	FC-AL: ANSI X.272
	FC-AL-2: ANSI NCITS 332-1999
	FC-SW: ANSI NCITS 321
	FC-SW-2: ANSI NCITS 355-2001
	FC-GS: ANSI X.288 (for FC switch)
	FC-GS2: ANSI NCITS 288 (for FC switch)
	SAS Serial Attached SCSI-1.1 (SAS-1.1)
	SAS Serial Attached SCSI-2.0 (SAS-2.0)
	SAS Serial Attached SCSI-3.0 (SAS-3.0)
	T10/1562D Rev.05 Serial Attached SCSI (SAS)
	T10/1601D Rev.07 Serial Attached SCSI Model-1.1 (SAS-1.1)

Name	Standard No.
	T10/1601D Rev.07 Serial Attached SCSI Model-1.1 (SAS-2.0)
	T10/1601D Rev.07 Serial Attached SCSI Model-1.1 (SAS-3.0)
	SFF 8301 form factor of 3.5' disk drive
	SFF 8323 3.5' disk drive form factor with serial connector
	SFF 8482 SAS plug connector
	SCSI 3 SAM-2: ANSI INCITS 366-2003
	SPC-2: ANSI INCITS 351-2001
	SBC: ANSI INCITS 306-1998
	PICMG3.0 Advanced Telecommunications Computing Architecture
	PICMG3.1 Ethernet/Fibre Channel Over PICMG3.0
	iSCSI RFC 3720/7143
TCP/IP system	SNMP v1
	SNMP v2c
	SNMP v3
PCIe system	PCI Express Base Specification R1.1
	PCI Express to PCI or PCI-X Bridge Specification v1.0
	PCI Express Base Specification v2.0

Interface Standards

Table 8-2 describes the interface standards that the storage systems comply with.

Table 8-2 Interface standards that the storage systems comply with

Name	Description
VAAI	An application programming interface (API) framework from VMware. It enables some storage-related tasks (such as thin provisioning) to be offloaded from a VMware server to a storage array.
VASA	An API used for VMware vSphere ESXi hosts to communicate with storage devices. It enables vCenter to manage storage arrays in a unified manner.

Name	Description
SRA	An interface between VMware Site Recovery Manager (SRM) and a storage system. It enables SRM to perform the following operations: discovery of storage systems, non-disruptive failover test, emergency or planned failover, reverse replication, backup, and restoration.
SMI-S	<p>A storage standard developed and maintained by the Storage Networking Industry Association (SNIA). It aims to simplify the management of a storage area network (SAN) that contains devices from various manufacturers. It provides a universal management interface for all types of network elements and simplifies the management of a heterogeneous SAN environment.</p> <p>NOTE Log in to http://support.huawei.com/enterprise/, in the search field, enter eSDK Storage, and select a path from the paths that are automatically displayed to go to the document page. Search, browse, and download the SMI-S Provider documents of the corresponding version to get more information.</p>
ODX	Offloaded data transfer (ODX) is a feature of Windows Server 2012. The feature unloads files into storage arrays for transmission. High transmission bandwidth between storage arrays largely shortens the data transmission delay and improves the data copy speed, as well as reduces host server resource occupation.

Safety Specifications and EMC Standards

Table 8-3 lists the safety specifications and EMC standards that the storage system complies with.

Table 8-3 Safety specifications and EMC standards

Name	Standard No.
China safety standard	GB 4943
North America safety standard	UL 60950-1
European safety directive	2014/35/EU
European safety standard	EN 60950-1
China EMC standard	GB9254-2008
	GB17625.1-2012
Canada EMC standard	ICES-003
	CAN/CSA-CEI/IEC CISPR 22:02

Name	Standard No.
North America EMC standard	FCC, CFR 47 Part 15, Subpart B
European EMC directive	EMC Directive 2004/108/EC
European EMC standard	EN 55032
	EN 55024

Industry Standards

Table 8-4 lists the industry standards that the storage system complies with.

Table 8-4 Industry standards

Name	Standard No.
Ethernet	IEEE 802.3
Fast Ethernet	IEEE 802.3u
Gigabit Ethernet	IEEE 802.3z
	IEEE 802.3ab
10-Gigabit Ethernet	IEEE 802.3ae
VLAN	IEEE 802.1q
IEEE standard test access port and boundary-scan architecture	IEEE 1149.1-2001
Procedure for failure modes and effects analysis (FMEA)	IEC 812
Presentation of reliability, maintainability and availability predictions	IEC 863
ETSI standard (environment)	ETS 300 019
ETSI standard (power)	ETS 300 132
ETSI standard (noise)	ETS 300 753
ETSI standard (environment)	ETS 300 119
ETSI standard (grounding)	ETS 300 253
ITUT standard (grounding)	ITUT K.27

Name	Standard No.
Environmental protection	ECMA TR/70
Reliability	GR-929, Telcordia SR-332
Clean room and related controlled environments	ISO 14664-1 Class8
Airborne contaminants and environment standards	ANSI/ISA-71.04-1985 severity level G1

9 Certifications

The chapter describes the certifications of the storage system.

Table 9-1 lists the certifications that the storage system obtains.

Table 9-1 Certifications

Name	Description
CB	<p>The IEC System for Conformity Testing and Certification of Electrical Equipment (IECEE) is based on the use of specific IEC standards for electrical equipment. The Certification Bodies (CB) Scheme is applicable to electrical equipment within the scope of IEC standards for safety, accepted for use in the IECEE. The Scheme becomes operative for such standards as soon as at least one National Certification Body has declared their recognition of CB Test Certificates. The CB scheme is designed for eliminating the international commerce barriers resulted from the compliance with certifications and approval guidelines of different countries.</p> <p>The IEC System for Conformity Testing to Standards for Safety of Electrical Equipment (referred to as the IECEE) is based on the use of specific IEC standards for electrical equipment. The CB Scheme is applicable to electrical equipment within the scope of IEC standards for safety, accepted for use in the IECEE. The Scheme becomes operative for such standards as soon as at least one National Certification Body has declared their recognition of CB Test Certificates.</p>
CCC	<p>China Compulsory Certification (CCC) is a three-in-one authoritative certification incorporating the Conformity Certification of Electrical Equipment (CCEE), the certificate for the safe license of import granted by China Commodity Inspection Bureau (CCIB), and Safety and Electro Magnetic Compatibility (EMC).</p> <p>The China Compulsory Certificate (CCC) mainly involves the products related to human health and security, animal and plant life and health, environmental protection, and public security.</p>

Name	Description
FCC	Federal Communications Commission (FCC) authorizes and manages all RF transmission facilities and devices except for those used by the federal government. It is also responsible for the environmental damages generated by the facilities and devices it approves.
IC	Industry Canada (IC) sets up the test standards for analog and digital terminal devices and specifies corresponding EMC certificates that all import electronic products must obtain.
UL	<p>Underwriters Laboratories Inc. (UL): The UL is a non-profit agency engaged in product safety testing.</p> <p>UL has its own certification system for the entire system, components, and materials. All electric products that are exported to the USA must pass the UL certification.</p> <p>The UL safety certification is classified into the following three methods:</p> <ul style="list-style-type: none"> ● Labeling The UL labeling service is the best known service of the UL safety certification. The UL label on the product indicates that UL has tested the sample of the product according to the safety standards approved by the USA. The sample does not cause fire, creepage, or other dangers if predictable. ● Classification UL tests the product according to different features, in the specified danger range, or under specific cases. In general, the classified products are mostly construction materials or industrial instruments. The classified products include industrial or commercial products. Some specified features must be tested, such as inflammability, hazardous performance, or specifications specified by the government. ● Approval UL tests parts of the product or unfinished product. These parts will be used in the UL labeled product list. This service covers millions of plastics, wires, circuit boards, various finished products, and even some large components, such as motorcycles or power supplies.
CE	<p>Conformite Europeenne (CE): Products marked with CE conform to EMC (2014/30/EU) and low-voltage (2014/35/EU) specifications published by EU.</p> <p>If this product has telecommunication functionality, the R_TTE Directive (1999/5/EC) that complies with the directives mentioned previously implies conformity to the following European norms (in parentheses are the equivalent international standards and regulations):</p> <ul style="list-style-type: none"> ● EN 55032 (CISPR 32)-Electro Magnetic Interference ● EN 55024 (IEC61000-4-2, 3, 4, 5, 6, 8, 11)-Electro Magnetic Immunity ● EN 60950 (IEC 60950)-Product Safety
REACH	REACH is a set of comprehensive regulations that require all chemical products that are both imported and produced in Europe must be registered, assessed, authorized, and restricted. In this way, customers can easily recognize the chemical elements. As a result, both humans and environment are protected.

Name	Description
RoHS	<p>The restriction of the use of certain hazardous substances in electrical and electronic equipment (RoHS) is the directive that restricts the use of certain hazardous substances in the electrical, electronic equipment.</p> <p>RoHS is the European Union (EU) compulsory standard that is designed to regulate the materials and the technical standard of the electrical and electronic products. In this way, it does good to human health and environment protection. That is, the six hazardous substances of lead (Pb), mercury (Hg), cadmium (Cd), hexavalent chromium (Cr6+), polybrominated biphenyl (PBB), polybrominated diphenyl ethers (PBDE) cannot exceed the specified limits.</p>
WEEE	<p>The EU Directive on Waste of Electric and Electronic Equipment. Electrical and electronic products sold in the EU market must comply with this directive and have the mark of cross out wheeled bin.</p>
CU-TR	<p>Russia, Kazakhstan, and Belarus have integrated their own certification technology requirements and formulated a unified Customs Union (CU) certification. The products within the scope of control are subject to mandatory certification of customs union technical regulations (CU-TR), unified technical regulations and evaluation modes, product qualification directories, certificate forms, and technical supervision and registration.</p>
RCM	<p>The Australian & New Zealand Regulatory Compliance Mark (RCM) is the mandatory compliance for selling electrical equipment products in the market.</p>
SONCAP	<p>A certification issued by Standards Organization of Nigeria. The products in the certification item list must acquire SONCAP for the entrance to Nigeria market.</p>

Security Symbol (CCC)

The product is a Class A device based on the CCC. Use of it in a residential area is likely to cause radio interference. Users may be required to prevent the interference by taking protective measures.

10 Operation and Maintenance

The storage systems can be operated and maintained by using DeviceManager and the command-line interface (CLI), adapting to different environments and user habits.

Introduction to DeviceManager

Figure 10-1 shows the DeviceManager main window.

Figure 10-1 DeviceManager main window

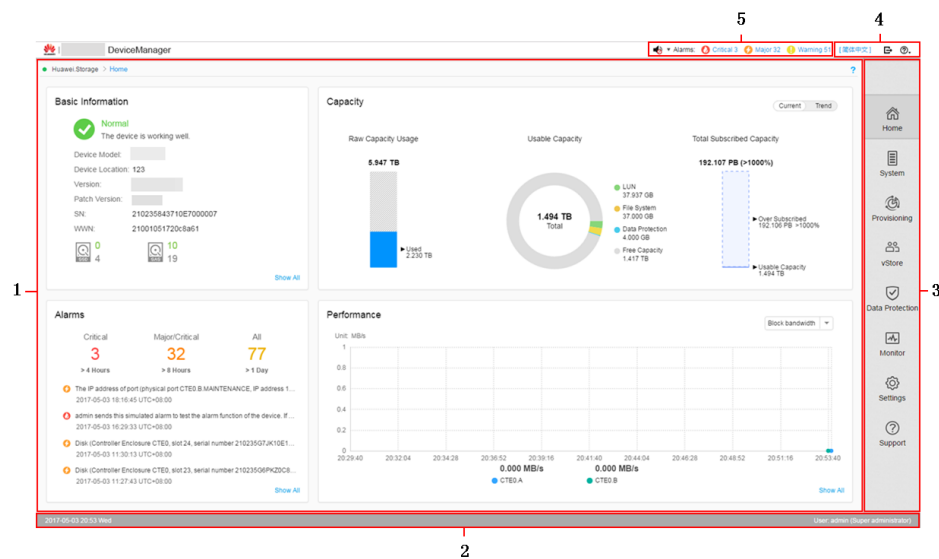

Table 10-1 describes the components of the DeviceManager main window.

Table 10-1 Components of the DeviceManager main window

No.	Name	Description
1	Function pane	The function pane shows a page associated with the current operation.

No.	Name	Description
2	Status bar	The status bar shows information such as the user name currently logged in and the login time.
3	Navigation bar	The navigation bar shows the function modules of a storage system. Users can click a function module to configure the corresponding functions.
4	Exit, help, and language selection area	This area displays an exit button, a help button, and a language selection button.
5	Fault statistics area	The fault statistics area shows the number of each level of system faults, helping users understand the running status of a storage system.

Users can log in to DeviceManager by using a common browser.

To master GUI-based operations, you are advised to read this document and practice the operations using the DeviceManager Demo. As a simulation program of storage system management software, the DeviceManager Demo simulates configuration and management operations on a storage system.

Introduction to the CLI

After logging in to the storage system through the command line interface (CLI), you can query, set, manage, and maintain the storage system.

You can log in to the storage system by either of the following methods:

- Through the service processor (SVP)
 - From a local computer
 - From a remote desktop
- Through the remote login software
 - You can log in to the CLI by using the IPv4 address or IPv6 address.
 - After the SVP management network port is connected to the maintenance terminal by a network cable, you can log in to the storage system by using the remote login software (for example, PuTTY) that supports the SSH protocol.

A How to Obtain Help

If a tough or critical problem persists in routine maintenance or troubleshooting, contact Huawei for technical support.

[A.1 Preparations for Contacting Huawei](#)

To better solve the problem, you need to collect troubleshooting information and make debugging preparations before contacting Huawei.

[A.2 How to Use the Document](#)

Huawei provides guide documents shipped with the device. The guide documents can be used to handle the common problems occurring in daily maintenance or troubleshooting.

[A.3 How to Obtain Help from Website](#)

Huawei provides users with timely and efficient technical support through the regional offices, secondary technical support system, telephone technical support, remote technical support, and onsite technical support.

[A.4 Ways to Contact Huawei](#)

Huawei Technologies Co., Ltd. provides customers with comprehensive technical support and service. For any assistance, contact our local office or company headquarters.

A.1 Preparations for Contacting Huawei

To better solve the problem, you need to collect troubleshooting information and make debugging preparations before contacting Huawei.

A.1.1 Collecting Troubleshooting Information

You need to collect troubleshooting information before troubleshooting.

You need to collect the following information:

- Name and address of the customer
- Contact person and telephone number
- Time when the fault occurred
- Description of the fault phenomena
- Device type and software version

- Measures taken after the fault occurs and the related results
- Troubleshooting level and required solution deadline

A.1.2 Making Debugging Preparations

When you contact Huawei for help, the technical support engineer of Huawei might assist you to do certain operations to collect information about the fault or rectify the fault directly.

Before contacting Huawei for help, you need to prepare the boards, port modules, screwdrivers, screws, cables for serial ports, network cables, and other required materials.

A.2 How to Use the Document

Huawei provides guide documents shipped with the device. The guide documents can be used to handle the common problems occurring in daily maintenance or troubleshooting.

To better solve the problems, use the documents before you contact Huawei for technical support.

A.3 How to Obtain Help from Website

Huawei provides users with timely and efficient technical support through the regional offices, secondary technical support system, telephone technical support, remote technical support, and onsite technical support.

Contents of the Huawei technical support system are as follows:

- Huawei headquarters technical support department
- Regional office technical support center
- Customer service center
- Technical support website: <http://support.huawei.com/enterprise/>

You can query how to contact the regional offices at <http://support.huawei.com/enterprise/>.

A.4 Ways to Contact Huawei

Huawei Technologies Co., Ltd. provides customers with comprehensive technical support and service. For any assistance, contact our local office or company headquarters.

Huawei Technologies Co., Ltd.

Address: Huawei Industrial Base Bantian, Longgang Shenzhen 518129 People's Republic of China

Website: <http://enterprise.huawei.com/>

B Glossary

If you want to obtain information about glossaries, visit <http://support.huawei.com/enterprise/>. In the search field, enter product model, and select a path from the paths that are automatically displayed to go to the document page of the product. Browse or download the *OceanStor V5 Series V500R007 Glossary*.

C Acronyms and Abbreviations

A

ANSI American National Standards Institute

B

BBU Backup Battery Unit

C

CLI Command Line Interface

E

ESN Equipment Serial Number

F

FC Fibre Channel

FC-AL Fibre Channel Arbitrated Loop

FCoE Fibre Channel over Ethernet

G

GUI Graphical User Interface

GE Gigabit Ethernet

H

HBA Host Bus Adapter

HD	High Density
I	
IP	Internet Protocol
ISA	Instrument Society of America
iSCSI	Internet Small Computer Systems Interface
ISO	International Organization for Standardization
L	
LUN	Logical Unit Number
M	
MTBF	Mean Time Between Failures
MTTR	Mean Time to Repair
N	
NL-SAS	Near Line Serial Attached SCSI
P	
PDU	Power Distribution Unit
U	
USB	Universal Serial Bus
R	
RAID	Redundant Array of Independent Disks
RSCN	Registered State Change Notification
S	
SAN	Storage Area Network
SAS	Serial Attached SCSI
SCSI	Small Computer System Interface

SSD	Solid State Drive
V	
VLAN	Virtual Local Area Network
VPN	Virtual Private Network