

# Huawei Agile Campus Solution Technology White Paper - IoT Convergence

Issue 1.0  
Date 2017-09-08

**Copyright © Huawei Technologies Co., Ltd. 2017. All rights reserved.**

No part of this document may be reproduced or transmitted in any form or by any means without prior written consent of Huawei Technologies Co., Ltd.

## **Trademarks and Permissions**



HUAWEI and other Huawei trademarks are trademarks of Huawei Technologies Co., Ltd.

All other trademarks and trade names mentioned in this document are the property of their respective holders.

## **Notice**

The purchased products, services and features are stipulated by the contract made between Huawei and the customer. All or part of the products, services and features described in this document may not be within the purchase scope or the usage scope. Unless otherwise specified in the contract, all statements, information, and recommendations in this document are provided "AS IS" without warranties, guarantees or representations of any kind, either express or implied.

The information in this document is subject to change without notice. Every effort has been made in the preparation of this document to ensure accuracy of the contents, but all statements, information, and recommendations in this document do not constitute a warranty of any kind, express or implied.

## **Huawei Technologies Co., Ltd.**

Address: Huawei Industrial Base  
Bantian, Longgang  
Shenzhen 518129  
People's Republic of China

Website: <http://www.huawei.com>

Email: [support@huawei.com](mailto:support@huawei.com)

---

# About This Document

---

## Key words

IoT, BLE, RFID

## Abstract

On the basis of Wi-Fi, WLAN access points (APs) achieve convergence of Internet of Things (IoT) applications and Wi-Fi through built-in Bluetooth modules and built-in IoT cards (or external IoT expansion modules). The convergence achieves integration of WLAN and IoT networks, reduces network deployment and maintenance costs, and provides IoT value-added services (VASs) for users while meeting their Wi-Fi application requirements. The document describes basic principles and typical applications of WLAN AP and IoT convergence.

## Acronyms and Abbreviations

Acronym and Abbreviation	Full Name
AP	Access Point
AC	Access Controller
RFID	Radio Frequency Identification
BLE	Bluetooth Low Energy
IoT	Internet of Things
CSMA/CA	Carrier Sense Multiple Access with Collision Avoidance
ESL	Electronic Shelf Label

---

# Contents

---

<b>About This Document</b> .....	<b>ii</b>
<b>1 Overview</b> .....	<b>1</b>
1.1 Background.....	1
1.2 Huawei's WLAN and IoT Convergence Strategy .....	2
<b>2 Technical Implementation</b> .....	<b>3</b>
2.1 Implementation Architecture .....	3
2.2 Wireless Technology.....	5
<b>3 Huawei WLAN and IoT Convergence Solution</b> .....	<b>10</b>
3.1 Enterprise Office Asset Management .....	10
3.1.1 BLE-based Asset Management.....	10
3.1.2 RFID-based Asset Management .....	12
3.2 Healthcare IoT .....	14
3.2.1 Baby Theft Prevention.....	14
3.2.2 Healthcare Asset Management.....	18
3.2.3 Infusion Management .....	18
3.3 ESL.....	19
<b>4 Customer Benefits</b> .....	<b>21</b>

# 1 Overview

## 1.1 Background

Internet of Things (IoT) is the third wave of information industry revolution in the world and is considered the 'next big thing'. Since the appearance of many 'firsts' — automated teller machine (ATM), laptop, mobile phone, automobile, meter, and other objects that are connected to the network, more devices have connected to the network through various connection modes, such as cellular network, Near Field Communication (NFC), Radio Frequency Identification (RFID), Bluetooth, ZigBee, and Wi-Fi. According to Huawei's forecast, over 100 billion objects (excluding individual broadband users) will be connected to networks by 2025. Any object can be connected to the network anytime, anywhere. IoT is profoundly influencing production and living.

**Figure 1-1** Key elements of IoT

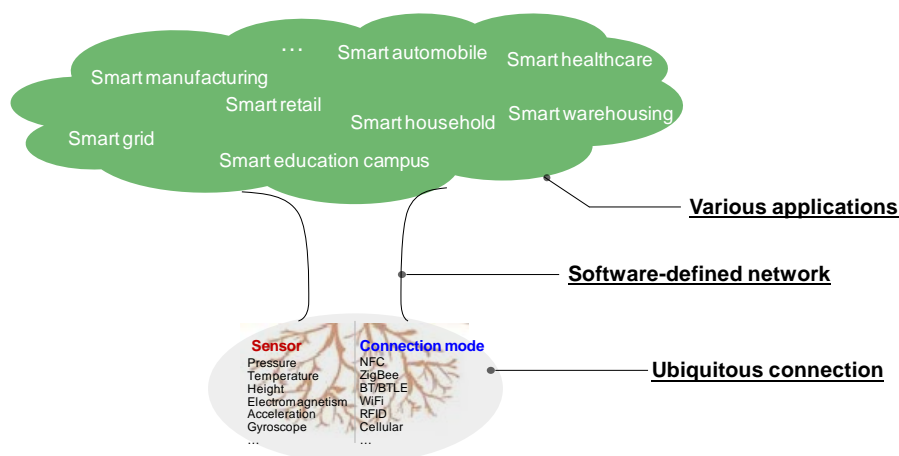

In an IoT network, various types of sensors obtain information from the physical world (information obtaining), and send the information to various types of intelligent applications (information transfer). The intelligent applications process the information and perform decision-making (information processing), and then impose the decision-making results on the physical world to make sure that the focused objects work in expected state (generation of information effects). Ubiquitous connections play a very important role in the process. Network products on the network edge are important in particular as they need to support various connection modes.

For example, valuable assets in an enterprise are attached with active RFID tags and RFID tag readers are deployed inside the enterprise. The RFID tag readers can track active RFID tags to manage valuable assets, and record moving tracks of valuable assets to achieve asset management such as automatic inventory checking. However, radio technologies used by active tags are diverse, such as RFID, Bluetooth Low Energy (BLE), and ZigBee. Access devices need to fast integrate with the various wireless access modes in the IoT field. This integration issue needs to be solved and is crucial to the large-scale promotion of IoT enterprise-grade applications in WLANs.

To enable the converged access, Huawei developed IoT APs. IoT connection modes, such as Bluetooth and RFID, are provided for Wi-Fi products that have been widely deployed and maturely applied. On the basis of Wi-Fi, Huawei's IoT AP solution achieves co-site, one backhaul, unified access, and unified management of various IoT connection modes on an AP, and supports flexibility and scalability.

IoT APs are the key breakthrough point for WLAN and IoT network convergence.

## 1.2 Huawei's WLAN and IoT Convergence Strategy

In the IoT field, the 'being integrated' strategy is used on Huawei WLAN products. This strategy helps build a pipe-based technical platform and eco-system and utilize professional advantages of partners in the IoT field, achieving fast convergence and response and helping customers gain most benefits.

Figure 1-2 Diagram of Huawei's WLAN and IoT convergence strategy

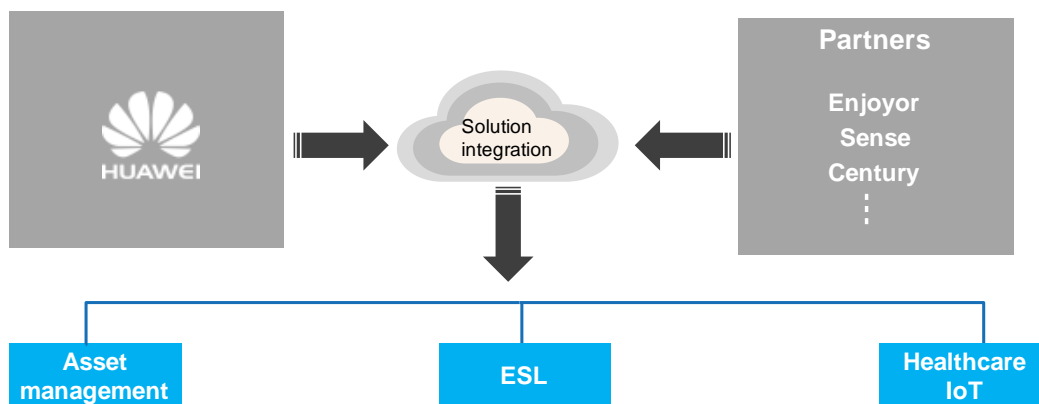

# 2 Technical Implementation

## 2.1 Implementation Architecture

Figure 2-1 Technical architecture of an IoT AP

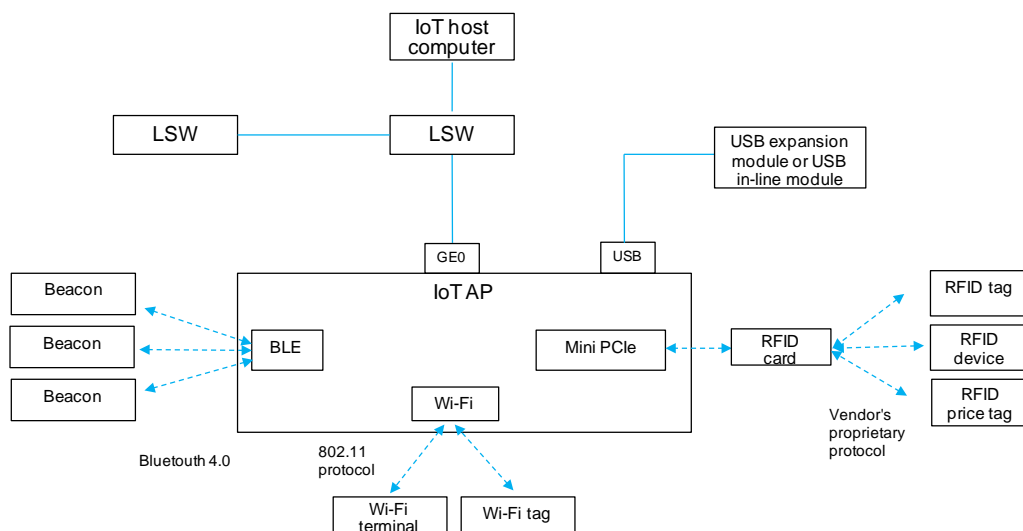
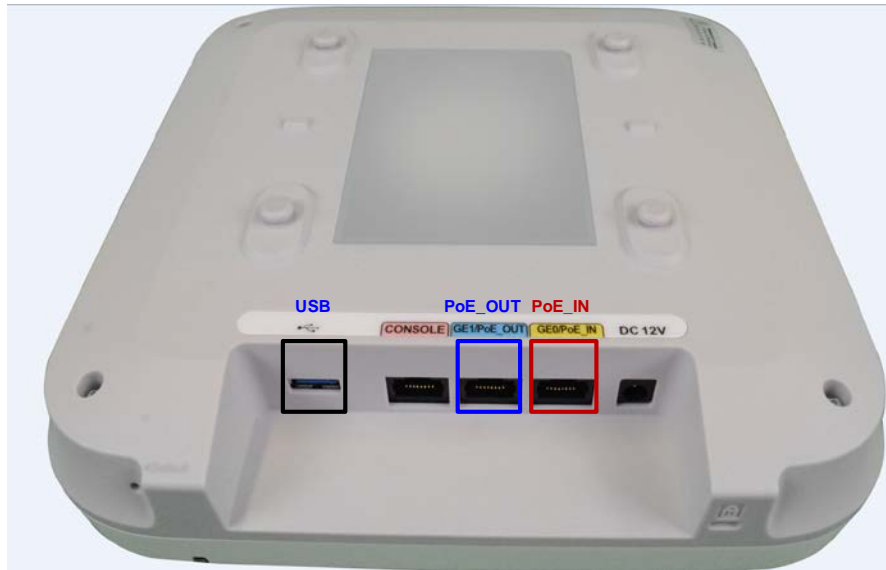

Figure 2-1 shows the technical architecture of an IoT AP. Huawei's IoT APs maintain the original Wi-Fi modules so the APs can provide the Wi-Fi access service for Wi-Fi terminals and provide the location function based on Wi-Fi tags. An IoT AP has a built-in Bluetooth 4.0 module which enables the AP to communicate with Beacons through the Bluetooth 4.0 protocol so as to provide the Bluetooth location service. Additionally, the IoT AP provides three standard Mini PCIe expansion slots for IoT modules complying with Mini PCIe interface standards. The IoT AP also provides a USB interface for a USB in-line module or a USB expansion module with a USB extension cable. IoT modules from various vendors connect to IoT terminals through expansion slots or USB interfaces and communicate with the IoT terminals using vendors' proprietary protocols. For IoT APs, the APs do not need to process vendors' proprietary protocols; instead, they only need to forward the data processed by each module.

The following takes the AP4050DN-E as an example and describes main physical interfaces of an IoT AP.

**Figure 2-2** Physical interface 1 of an IoT AP



**Figure 2-3** Physical interface 2 of an IoT AP

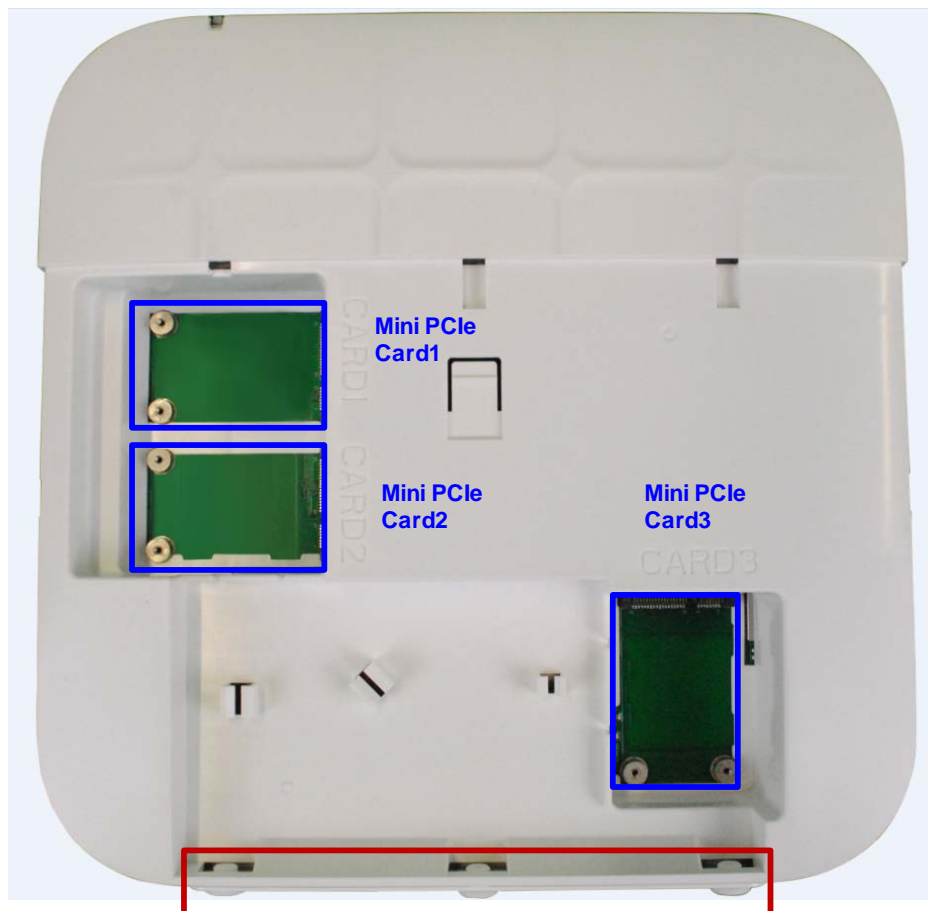

**The AP reserves external antenna interfaces for the IoT cards**



Figure 2-2 and Figure 2-3 show main interfaces provided by an IoT AP. Functions of the interfaces are listed in the following table.

No.	Interface	Quantity	Function
1	GE interface	2	<ol style="list-style-type: none"> <li>1. GE0 supports input of PoE power.</li> <li>2. GE0 supports output of PoE power.                             <ol style="list-style-type: none"> <li>(a) When the AP is not connected to IoT cards and its USB interface is not used, the AP can support an external device of up to 7 W.</li> <li>(b) When the AP is only connected to one IoT card and its USB interface is not used, the AP can support an external device of up to 5.5 W.</li> <li>(c) When the AP is connected to two or more IoT cards, or its USB interface is used, the PoE out function will be automatically disabled.</li> </ol> </li> <li>3. Both GE0 and GE1 can function as the AP's uplink interfaces to connect to access switches, and the interfaces support the trunking mode.</li> </ol>
2	Mini PCIe	3	<ol style="list-style-type: none"> <li>1. These interfaces are standard Mini PCIe physical interfaces used for IoT modules.</li> <li>2. The slots are located under the AP's cover and support external IoT antennas.</li> </ol>
3	USB	1	<ol style="list-style-type: none"> <li>1. This interface is a standard USB 2.0 interface (with a maximum output power of 2.5 W) and used for the expansion of IoT modules that are connected to USB interfaces.</li> <li>2. The interface can connect to a USB flash drive to extend the storage space of the AP.</li> </ol>

## 2.2 Wireless Technology

In IoT scenarios, many different wireless connection technologies are used, for example, 2G/3G/4G cellular technology, Wi-Fi, Bluetooth, RFID, ZigBee, and Long Range (LoRa). These technologies are different with regard to the coverage distance, supported bandwidth, and operating frequency. The following describes wireless access technologies, including RFID, Bluetooth, and ZigBee, supported by IoT APs.

- **RFID**

RFID is short for radio frequency identification. It automatically identifies target objects through radio signals, marks and registers the objects, and stores and manages object information.

An RFID system usually consists of three parts: electronic tag, reader/writer, and antenna.

- Electronic tag: consists of the chip and tag antenna or coil. It communicates with the reader/writer through inductive coupling or reflection of electromagnetic waves.

- Reader/writer: is a device that reads tag information (some readers/writers can also write tag information).
- Antenna: works with both electronic tags and readers/writers. An electronic tag usually has a built-in antenna. A reader/writer can have a built-in antenna or have an antenna connected to its antenna interface through a radio cable.

The following figure shows information exchange between the electronic tag, reader/writer, and information processing system.

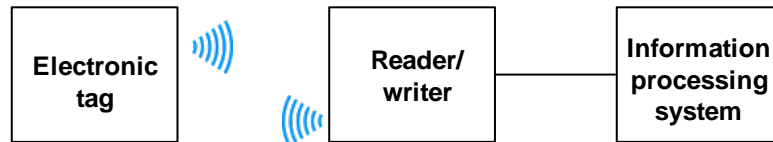

- (1) The reader/writer encodes information to be transmitted, loads the encoded information onto a high frequency carrier signal, and transmits the information through the antenna.
- (2) An electronic tag receives the signal when entering the working area of the reader/writer. The related circuit of the tag chip performs voltage-multiplying rectification, modulation, decoding, and decryption on the signal, and then determines the command, request, password, and rights.
- (3) If the command is a read command, the control logic circuit reads related information from the storage unit, encrypts, encodes, and modulates the information, and sends the information to the reader/writer through the chip antenna. After receiving the signal, the reader/writer demodulates, decodes, and decrypts the signal, and sends the information to the information system for processing.
- (4) If the command is a write command to modify information, the related control logic makes the internal charge pump of the electronic tag provide the working voltage to erase and re-write the Electrically Erasable Programmable Read-Only Memory (E2PROM). The tag returns an error message if the password and rights of the write command are different from those required by the tag.

The electronic tag and the reader/writer communicate with each other in wireless mode while the reader/writer and the information processing system communicate with each other in wired mode. On an IoT AP, the reader/writer is built in the AP as a card, and communicates with the information processing system through the IoT AP's uplink network interface. The working frequencies of wireless signals between electronic tags and readers/writers are categorized into three types: low frequency, high frequency, and ultrahigh frequency.

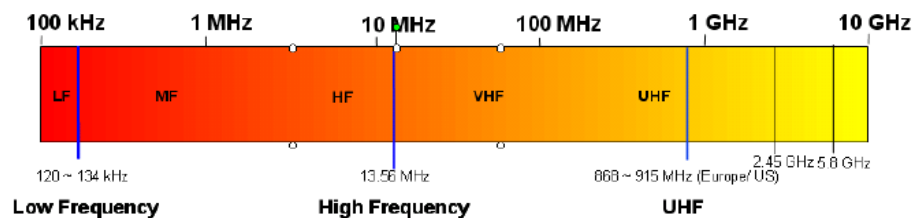

- (1) Low frequency: frequency in the range of 120 KHz to 134 KHz. Low frequency technology is mature, and most RFID products in the market work in low frequency. Low frequency features a small amount of data transmitted, slow transmission, and short read/write distance (less than 10 cm). It is mainly used in scenarios such as access control and attendance card swiping.

- (2) High frequency: frequency at 13.56 MHz. High frequency technology is mature, and the proportion of RFID products working in high frequency is next only to that of RFID products working in low frequency. High frequency features fast data transmission and short read/write distance (less than 1 m). It is mainly used in scenarios such as smart shelf and book management.
  - (3) Ultrahigh frequency: frequency in the range of 860 MHz to 960 MHz, and at 2.45 GHz and 5.8 GHz. RFID products working in ultrahigh frequency develop most rapidly. Ultrahigh frequency features fast data transmission and long read/write distance (3 m to 50 m). It is mainly used in scenarios such as supply chain management and logistics management.
- **Bluetooth 4.0**

Bluetooth is one of the most widely applied wireless technology standards for exchanging data over short distances. The Bluetooth Special Interest Group (SIG) released Bluetooth 4.0 in July 2010. Bluetooth 4.0 uses Bluetooth Low Energy (BLE) that is compatible with Classic Bluetooth. Bluetooth 4.0 provides two modes, including the single mode and the dual mode. The dual mode includes BLE and Classic Bluetooth, and the single mode includes only BLE. BLE provides a star topology architecture. The master device manages connections and can be connected to multiple slave devices. A slave device can connect to only one master device.

**Figure 2-4** BLE star topology architecture

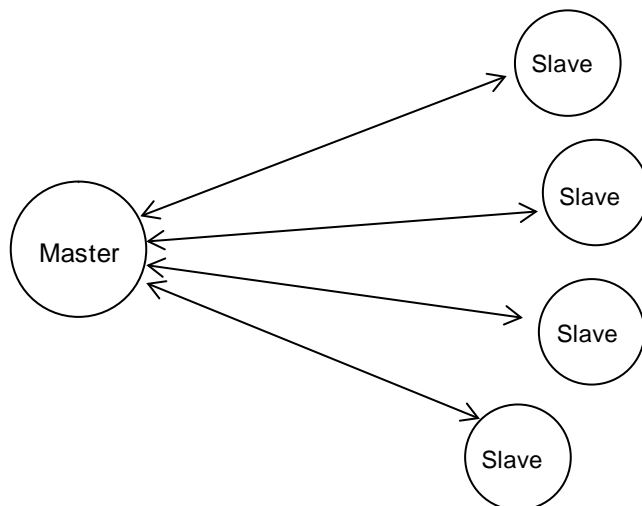

The master and slave devices communicate with each other in wireless mode. On an IoT AP, the master device uses the AP's uplink network interface to communicate with the Bluetooth server. BLE works in the 2.4 GHz frequency band and occupies 40 channels with 2 MHz bandwidth per channel. Three channels are fixed advertising channels and thirty-seven channels are data channels supporting frequency hopping (FH).

Figure 2-5 shows the master-slave communication connection process.

**Figure 2-5** BLE master-slave communication connection process

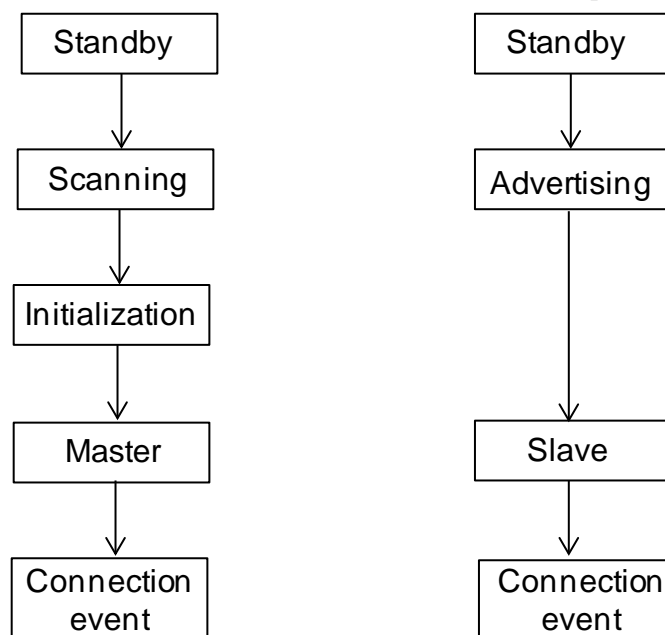

The process involves the following states:

- (1) Standby: The device does not transmit or send data, and is not connected to any device.
- (2) Advertising: The advertiser sends broadcast messages at a specified advertising interval on the three fixed advertising channels (including channels 37, 38, and 39). The broadcast messages are unidirectional and do not require any connection.
- (3) Scanning: The scanner listens to broadcast messages on the three fixed advertising channels 37, 38, and 39.
- (4) Initialization: During initialization, the scanner and the advertiser establish a connection. The scanner sends a connection request message which contains information such as the channel and time for sending the connection event. The advertiser receives the connection request. The scanner and the advertiser enter the connection status. The connection initiator (scanner) becomes the master device and the receiver (advertiser) becomes the slave device.
- (5) Connection event: Communications between the master and slave devices are called connection events. Connection events between the master and slave devices occur at a specified interval. Communication channels 0 through 36 perform FH based on the specified algorithm.

Both the master device and the slave device can actively end the connection. Once disconnection is initiated by one end, the other end must reply to the disconnection request before disconnection.

- **ZigBee**

ZigBee is a wireless communication technology for exchanging data over short distances with low power consumption. ZigBee features a short distance, self-organizing, low power consumption, and low data rate. The ZigBee standard is released by the ZigBee Alliance. Protocols for the physical layer and the Medium Access Control (MAC) layer are defined in IEEE 802.15.4. ZigBee supports three networking modes: star network, mesh network, and hybrid network (star+mesh).

Figure 2-6 ZigBee network topologies

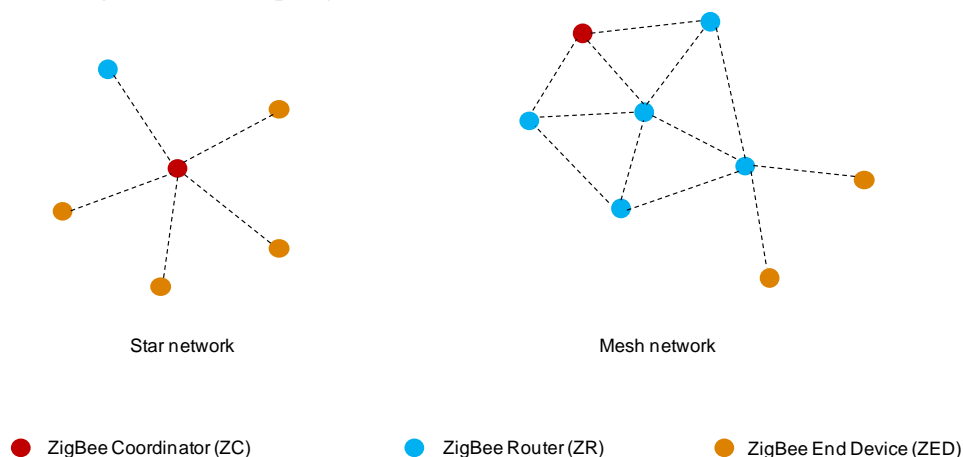

Nodes in ZigBee topologies are classified into ZigBee Coordinator (ZC), ZigBee Router (ZR), and ZigBee End Device (ZED). ZC is responsible for building and managing the entire network. After the network is built, ZC is also a ZR. ZR provides routing information and can allow other devices to access the network. ZED is an end node and is not responsible for network maintenance.

Nodes on a ZigBee network communicate with each other in wireless mode. ZigBee works in three frequency bands, that is, 868 MHz in Europe, 915 MHz in the USA, and 2.4 GHz worldwide. One channel is allocated in the 868 MHz band, with each channel spaced 0.6 MHz apart. Ten channels are allocated in the 915 MHz band, with each channel spaced 2 MHz apart. Sixteen channels are allocated in the 2.4 GHz band, with each channel spaced 5 MHz apart. ZigBee provides low data rates. The data rate is 250 kbit/s per channel in the 2.4 GHz band, 20 kbit/s in the 868 MHz band, and 40 kbit/s per channel in the 915 MHz band. ZigBee nodes communicate with each other based on Carrier Sense Multiple Access/Collision Avoidance (CSMA/CA) technology. (Two modes including CSMA/CA and Guaranteed Time Slot are defined. However, ZigBee does not actually provide related support for Guaranteed Time Slot.) ZigBee networks support two routing algorithms, that is, tree routing and mesh routing. Tree routing has only two directions: to the child node or to the parent node. Tree routing does not require routing tables, saving storage resources. However, it is inflexible and its routing efficiency is low. Mesh routing is actually a simplified version of the Ad hoc On-Demand Distance Vector (AODV) routing algorithm. Mesh routing is suitable for wireless ad hoc networks. Nodes need to maintain a routing table, consuming storage resources. However, mesh routing can achieve the optimal routing efficiency and is flexible.

# 3 Huawei WLAN and IoT Convergence Solution

---

## 3.1 Enterprise Office Asset Management

The WLAN and IoT convergence solution for enterprise office asset management mainly uses BLE and RFID technologies.

### 3.1.1 BLE-based Asset Management

BLE-based asset management uses BLE tag location. BLE tags are attached to valuable assets of an enterprise to uniquely identify the assets. BLE tags periodically send broadcast frames. Built-in Bluetooth modules of APs listen on the broadcast frames and report the signal strength and time stamps of received BLE tag frames to the location engine for location calculation. The asset management server graphically displays the location results to achieve real-time tracking and location of assets, and supports asset track check and automatic inventory check.

**Figure 3-1** Networking diagram for BLE-based asset management

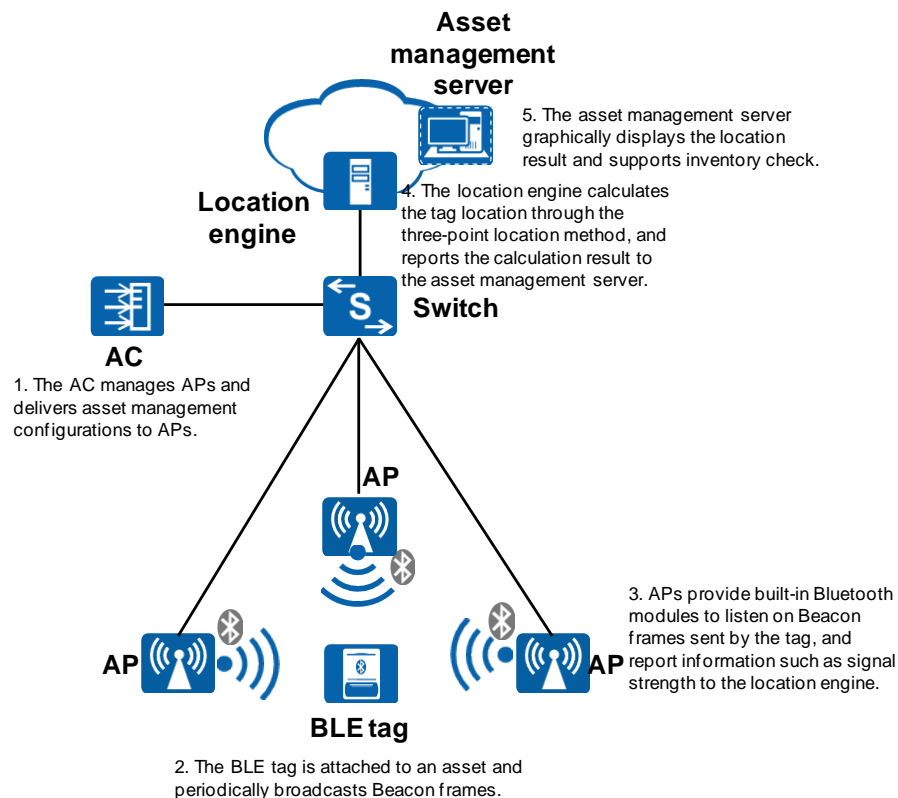

In this solution, tags used for asset management use the BLE technology and have low power consumption. The battery service life of BLE tags can reach three to five years. Asset management uses an area location method, that is, RSSI-based three-point location. Area location can locate the area of an asset or the AP that covers the asset. Generally, the precision of area location is 20 m to 30 m, enabling enterprises to monitor valuable assets in real time. The following describes implementation of BLE-based asset management.

1. BLE tags send signals

BLE tags attached to assets to uniquely identify the assets periodically send broadcast Beacon frames. To ensure that the Beacon frames can be identified by Huawei APs with built-in Bluetooth modules, the frame formats of Beacon frames must conform to corresponding requirements in *Huawei Bluetooth Interface Specifications*. The specifications define frame formats which must adapt to three modes, including standard iBeacon, BLE tag, and BLE transparent. Asset management uses the BLE tag mode. According to the definition, a frame contains the tag type, battery level, dropping identifier, RSSI calibration value, and vendor-defined field. Currently, Huawei is cooperating with Minew on BLE tags.

2. Built-in Bluetooth modules of APs detect signals

Built-in Bluetooth modules of APs can work in three modes: iBeacon mode, tag mode, and transparent mode. Therefore, frames sent by tags must match the three modes. Asset management requires that built-in Bluetooth modules of APs must work in tag mode. In tag mode, built-in Bluetooth modules of APs can detect broadcast frames sent by BLE tags, and then encapsulate and send information such as signal strength, time stamps, and battery level.

 **NOTE**

The three working modes of built-in Bluetooth modules of WLAN APs are mutually exclusive. If a built-in Bluetooth module works in tag mode, it cannot work in iBeacon or transparent mode.

APs can send BLE tag information directly or through an access controller (AC). APs and ACs can send tag information in real time. They can also aggregate the information and send the information periodically. The modes of sending information can be configured on the AC interface based on partners' and customers' actual needs.

3. Location engine

A location engine performs location calculation based on tag information sent by APs or ACs. To parse the tag information, the location engine interconnecting with the APs and ACs must conform to *Huawei Bluetooth Interface Specifications*. The specifications define the interconnection format in the section about northbound interfaces of servers.

Currently, Huawei eSight can function as the BLE tag location engine.

 **NOTE**

Though eSight can function as a location engine for BLE tag-based asset management, there is no partner whose asset management products can interconnect with eSight at present. A partner needs to be found based on actual project requirements.

4. Asset management server

The asset management server is provided by a partner, and is used for asset management services. It supports graphical asset management and real-time monitoring based on the location data sent by the location engine, and can display moving tracks of assets. Currently, Bluepath is tentatively determined as the partner.

Interference between Bluetooth and Wi-Fi signals

Currently, 2.4 GHz Wi-Fi terminals have not been phased out. 2.4 GHz and 5 GHz radios coexist in the enterprise office scenario. BLE devices also work in the ISM 2.4 GHz frequency band. Therefore, interference occurs between 2.4 GHz Wi-Fi and 2.4 GHz BLE devices. To reduce the interference, take the following measures:

- Use channels 1, 6, 11 in the 2.4 GHz frequency band when APs are deployed on the live network and the Bluetooth system is enabled. Most of the time, BLE devices only provide broadcast services. As defined by the BLE protocol, BLE devices use three 2 MHz channels with the frequencies of 2402 MHz, 2426 MHz, and 2048 MHz as the advertising channels. The three channels are different from channels 1, 6, 11 (whose center frequencies are 2412 MHz, 2437 MHz, and 2462MHz, respectively) that are commonly used in a WLAN.
- Improve the deployment density of APs. APs' 2.4 GHz radio and Bluetooth radio are enabled alternately. That is, for two adjacent APs, one AP is enabled with the 2.4 GHz radio but disabled with the Bluetooth radio, while the other AP is enabled with the Bluetooth radio but disabled with the 2.4 GHz radio.

 **NOTE**

According to the actual diagnostic test, when Wi-Fi is enabled, the effective transmission distance of BLE tags is approximately 10 m because of interference.

## 3.1.2 RFID-based Asset Management

RFID-based asset management uses RFID tags to uniquely identify assets by binding the RFID tags with the assets. RFID tags periodically send broadcast frames. RFID readers receive the broadcast frames and send the information on signal strength and tags to the asset management server. The asset management server graphically displays the location results to achieve real-time tracking and location of assets, and supports asset track check and automatic inventory check.



**Figure 3-2** Networking diagram for RFID-based asset management

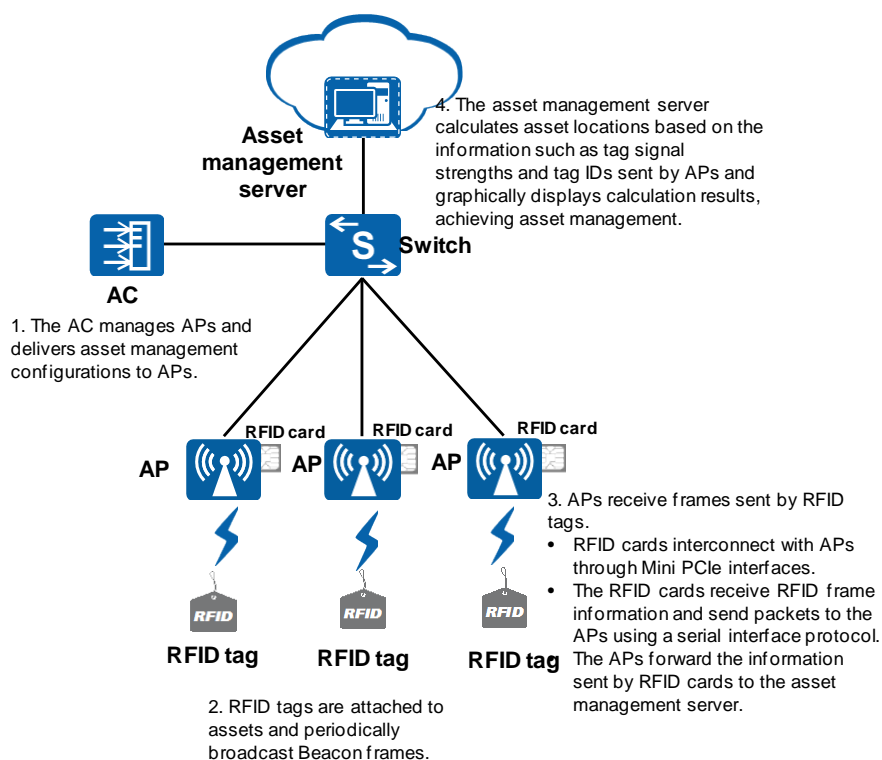

RFID-based asset management uses the ISM 2.4 GHz frequency band and has low power consumption. The battery life of RFID tags can reach three to five years. Area location of RFID tags is based on the coverage scope of RFID readers. After receiving an RFID tag signal, RFID readers send information such as signal strength to the asset management server. The asset management server determines the RFID reader that covers the tag based on the signal strength. Generally, the precision of area location is 20 m to 30 m, enabling enterprises to monitor valuable assets in real time. RFID-based asset management is different from BLE-based asset management with regard to tag readers. A BLE tag reader is a built-in Bluetooth module of an AP. However, an RFID tag reader is an RFID card inserted into a Mini PCIe interface on an IoT AP. The following describes implementation of RFID-based asset management.

1. RFID cards receive RFID tag signals

RFID tags attached to assets to uniquely identify the assets periodically send broadcast Beacon frames. RFID cards identify and read the Beacon frames. The RFID cards and RFID tags conform to the partner's proprietary protocol, and Huawei does not define the formats of frames sent by RFID tags.

Currently, RFID tags and RFID cards used in the RFID-based asset management solution are provided by Sense Technology.

2. RFID cards interconnect with IoT APs

RFID cards interconnect with IoT APs through Mini PCIe interfaces on the IoT APs. Partners need to provide RFID cards based on Huawei's Mini PCIe interface specifications to ensure that the RFID cards can successfully interconnect with IoT APs on hardware.

RFID cards communicate with APs using a serial interface protocol. Currently, APs' Mini PCIe interfaces provide serial interface baud rates of 115200 bit/s, 57600 bit/s, 38400

bit/s, 19200 bit/s, and 9600 bit/s. These baud rates can be configured or selected based on RFID cards from different vendors.

Though APs function only as the backhaul pipes and do not need to identify services carried on RFID cards when communicating with the RFID cards, the APs need to accurately identify whether the RFID cards have sent complete data and whether the data can be converted into Ethernet packets and forwarded. Therefore, software interfaces of RFID cards from partners must conform to Huawei's Mini PCIe interface software communication specifications.

### 3. Asset management server

The RFID asset management server is provided by a partner. After APs receive data from RFID cards, the APs send the data to the asset management server through uplink Ethernet links based on the configured IP address and interface number of the host computer. The asset management server monitors assets in real time and displays their moving tracks. The asset management server is provided by Sense Technology.

Sense Technology's RFID asset tags and cards use 2.425 GHz of the ISM 2.4 GHz frequency band with 1 MHz bandwidth. During network deployment, the Wi-Fi 2.4 GHz frequency band can be properly planned to reduce interference.

## 3.2 Healthcare IoT

Huawei's WLAN and healthcare IoT convergence solution uses the RFID technology. WLAN APs integrate RFID readers through their Mini PCIe or USB interfaces, achieving WLAN and healthcare IoT convergence. Currently, Huawei is cooperating with Enjoyor on healthcare IoT. Huawei provides WLAN devices such as APs and ACs, and Enjoyor provides healthcare-related devices, such as host computer system for healthcare management, infusion monitoring, mother and baby wristbands, RFID cards, and RFID USB expansion modules.

Healthcare IoT includes three sub-scenarios: baby theft prevention, infusion management, and healthcare asset management.

### 3.2.1 Baby Theft Prevention

Baby theft prevention includes the following sub-functions:

Mothers and babies wear mother wristbands and baby wristbands, respectively. The wristbands are consisted of medical straps and security RFID transceivers. Mother wristbands and baby wristbands identify each other through RFID to achieve mother-baby matching and prevent babies from being incorrectly carried away.

RFID readers and exit monitors are deployed in wards. The RFID modules of wristbands identify the exit monitors and send the information on exit monitors. The RFID readers receive the information sent by wristbands and send it to the server. The server displays locations of babies in real time based on the information such as IDs of exit monitors.

Exit monitors and audible and visual sensors are deployed at key entrances and exits in the ward area. When wristbands are near to the exit monitors, the exit monitors identify baby wristbands and trigger alarm reporting by the audible and visual sensors, enabling the geo-fence to prevent thefts.

**Figure 3-3** Networking diagram for baby theft prevention

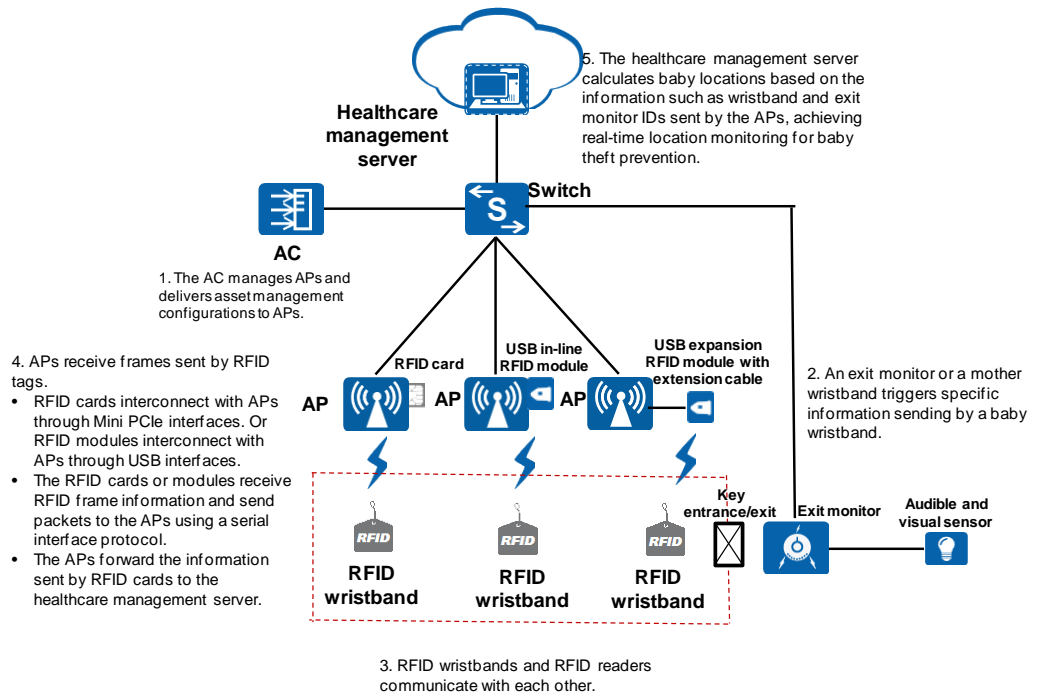

Baby theft prevention wristbands use the RFID technology. The wristbands include mother wristbands and baby wristbands. Both mother wristbands and baby wristbands include two radio modules, including one 433 MHz radio module and one 125 KHz radio module. The 433 MHz radio module is responsible for communicating with RFID readers and receiving/sending RFID information. The 125 KHz radio module of a mother wristband periodically sends RFID Beacon frames. The 125 KHz radio module of a baby wristband works in listening mode and listens on 125 KHz Beacon frames sent by mother wristbands or exit monitors. Baby theft prevention includes mother-baby matching, area location of babies, and geo-fence for baby theft prevention.

### 1. Mother-baby matching

Figure 3-4 Mother-baby matching process

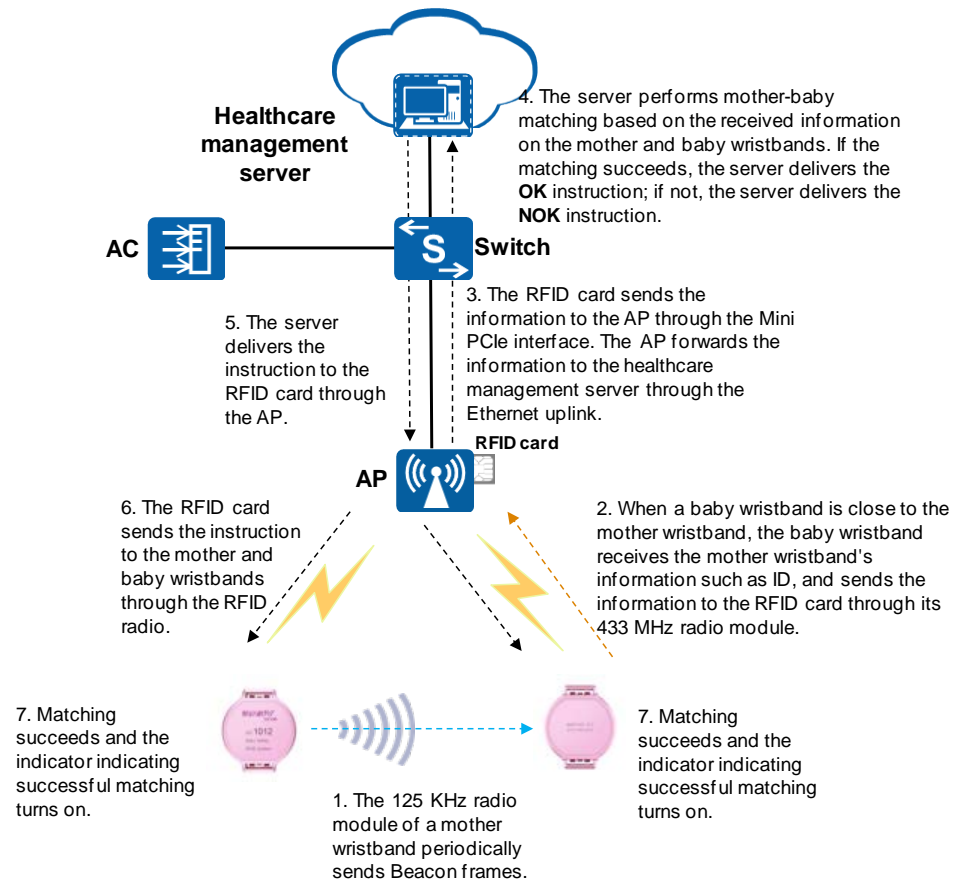

- (1) Mother wristbands and baby wristbands are bound and paired on the backend server. The 125 KHz radio module of a mother wristband periodically sends Beacon frames.
- (2) When a mother wristband and a baby wristband are close enough, the baby wristband will receive the Beacon frames sent by the 125 KHz radio module of the mother wristband. After receiving the information on the mother wristband, the baby wristband uses its 433 MHz radio module to send the information such as mother wristband ID and its own information to the RFID card.

 **NOTE**

In the healthcare IoT solution, the RFID readers that can integrate with WLAN APs include RFID cards as well as USB in-line modules and USB expansion modules with USB extension cables.

- (3) The RFID card sends a packet containing the information to the AP using a serial interface protocol. The AP converts the packet into an Ethernet packet and sends it to the healthcare management server through the Ethernet uplink.
- (4) After receiving the information on mother and baby wristbands, the healthcare management server queries mapping between mothers and babies to check whether the mother and baby are matched. If the matching succeeds, the server delivers the **OK** instruction.
- (5) After receiving the instruction, the AP converts the Ethernet packet into a serial interface packet, and sends it to the RFID card.
- (6) The RFID card sends the **OK** instruction delivered by the server to the mother and baby wristbands.

- (7) After the mother and baby wristbands receive the instruction of successful matching, the indicators on the wristbands indicating successful matching turn on.

2. **Baby location monitoring and baby theft prevention**

**Figure 3-5** Baby theft prevention process

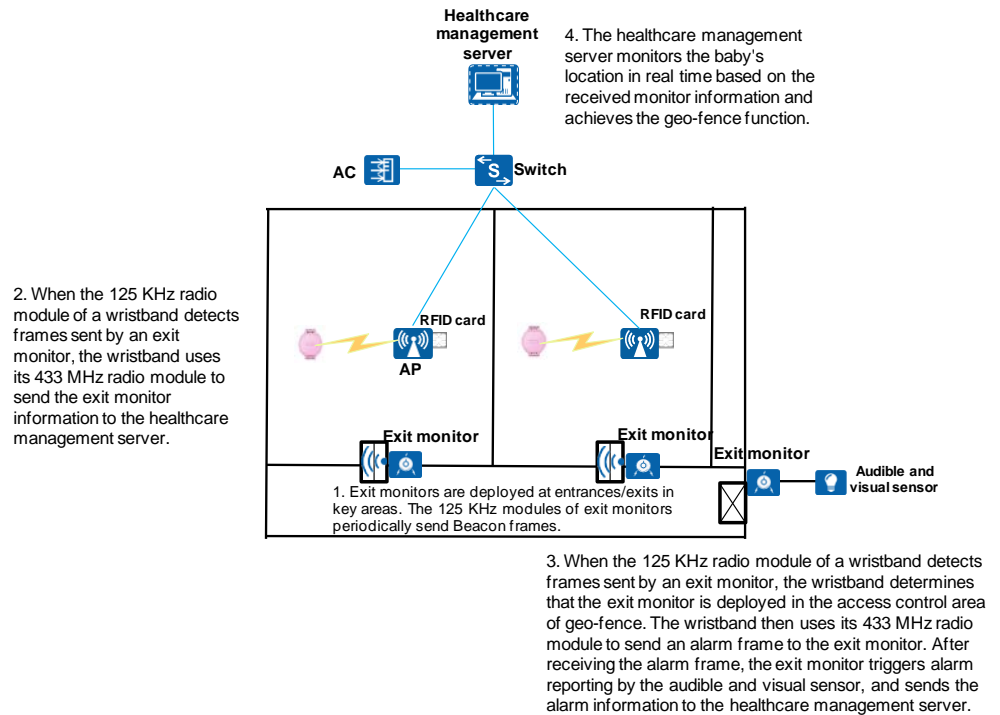

- (1) Exit monitors are deployed at key entrances and exits in the ward area. Exit monitors and audible and visual sensors are deployed in the access control area of geo-fence. Exit monitors connect to the switch through wired Ethernet links. Location information of exit monitors is configured on the healthcare management server.
- (2) During moving, when a baby is close to an exit monitor (the distance is usually less than 4 m), the 125 KHz module of the baby wristband can detect the Beacon frames sent by the exit monitor. The baby wristband identifies the received information, and uses its 433 MHz radio module to send the information, such as the exit monitor ID, to the RFID card. The RFID card sends a packet containing the information to the AP using a serial interface protocol. The AP transmits the packet to the healthcare management server through the Ethernet uplink.
- (3) If the exit monitor is deployed in the access control area of geo-fence, the 125 KHz radio module of the exit monitor sends special Beacon frames. When the baby wristband detects the frames, it uses its 433 MHz radio module to send alarm information to the 433 MHz radio module of the exit monitor. After receiving the alarm information, the exit monitor immediately triggers alarm reporting by the audible and visual sensor, and sends the alarm information to the healthcare management server.
- (4) The healthcare management server locates the area of the baby and monitors the baby' location in real time based on the received information such as exit monitor ID. It also achieves baby theft prevention and records information such as alarms on baby theft prevention.

## 3.2.2 Healthcare Asset Management

The implementation of healthcare asset management is the same as that of baby theft prevention. Healthcare asset management uses RFID tags which are similar to baby wristbands for asset binding. The RFID tags also have 433 MHz and 125 KHz radio modules. Similarly, healthcare asset management also achieves asset area location by identifying locations of exit monitors.

1. An asset tag is attached to an asset to uniquely identify the asset.
2. During moving, the 125 KHz radio module of the asset tag detects Beacon frames sent by an exit monitor. The asset tag uses its 433 MHz radio module to send the exit monitor information and its own information including tag ID to the RFID card.
3. The RFID card sends a packet containing the information to the AP using a serial interface protocol. The AP converts the packet into an Ethernet packet and sends the packet to the asset management server through the Ethernet uplink.
4. The asset management server identifies the area of the asset based on the information such as exit monitor ID. It realizes asset management functions such as asset area location and real-time asset monitoring.

## 3.2.3 Infusion Management

Infusion management uses infusion sensors to report the infusion situation to the infusion management service platform in real time, achieving monitoring of the entire infusion process, preventing accidents, and ensuring timely change of infusions for patients.

**Figure 3-6** Infusion management diagram

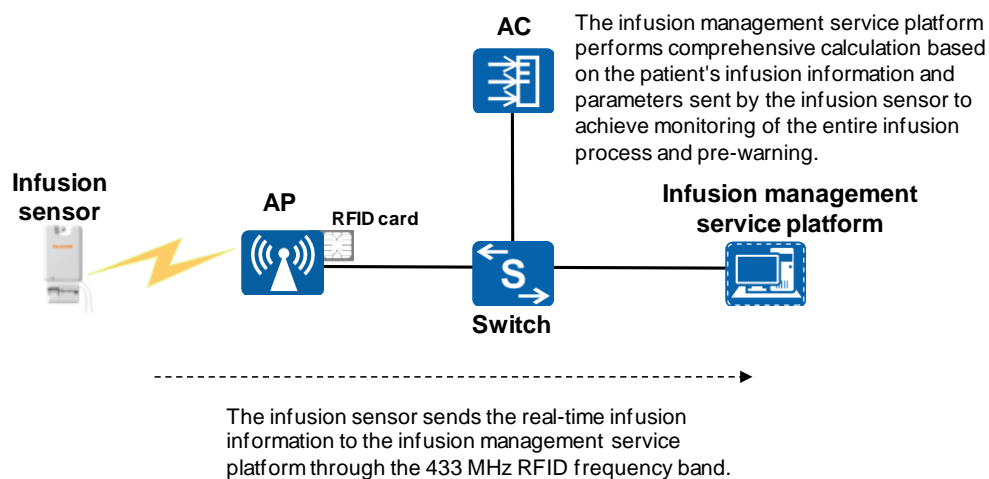

When a patient is infused in the hospital, the patient wears a wristband. The patient's basic information, diagnosis information, bed number, infusions information, and infusion process are recorded into the database. A handheld terminal is used to scan the barcode on the patient's wristband to obtain the patient's infusion information from the database.

When infusing drugs for a patient, the medical staff scan the barcode on the patient's wristband, so the infusion management service platform can obtain the patient's infusion information. The infusion management service platform adjusts basic parameters based on different infusions. The infusion sensor sends the infusion process data. The infusion management service platform performs comprehensive calculation based on the patient's

infusion information and parameters sent by the infusion sensor to achieve monitoring of the entire infusion process and pre-warning.

1. When infusing drugs for a patient, the medical staff scan the barcode on the patient's wristband using a mobile scanning terminal, so the infusion management service platform can obtain the patient's infusion information.
2. The infusion sensor sends the infusion parameters to the RFID card through its 433 MHz radio module.
3. The RFID card uses a serial interface protocol to send a packet containing the infusion parameters to the AP through the Mini PCIe interface. The AP converts the packet into an Ethernet packet, and sends the packet to the infusion management service platform through the Ethernet uplink.
4. The infusion management service platform performs comprehensive calculation based on the infusion information parameters and sensor parameters and displays the calculation result. It achieves functions such as monitoring of the entire infusion process and pre-warning of risks.

Enjoyer's healthcare IoT devices mainly use 433 MHz and 125 KHz RFID frequency bands. These bands are far away from the 2.4 GHz and 5 GHz Wi-Fi frequency bands, and therefore the mutual interference is low.

### 3.3 ESL

Electronic shelf labels (ESLs) display prices on electronic paper or liquid crystal display (LCD) screens. ESLs can automatically obtain update content from a server through radios, reducing manual price update costs. Some ESLs can display more content, such as discounts, promotions and product specifications.

Huawei's WLAN ESL convergence solution uses the RFID technology, which operates in ISM 2.4 GHz ISM bands. By collaborating with Hangzhou Century Co.,Ltd (Century for short), Huawei provides WLAN devices such as IoT APs and ACs, while Century offers ESLs, ESL cards, and the ESL management system.

Figure 3-7 ESL working process

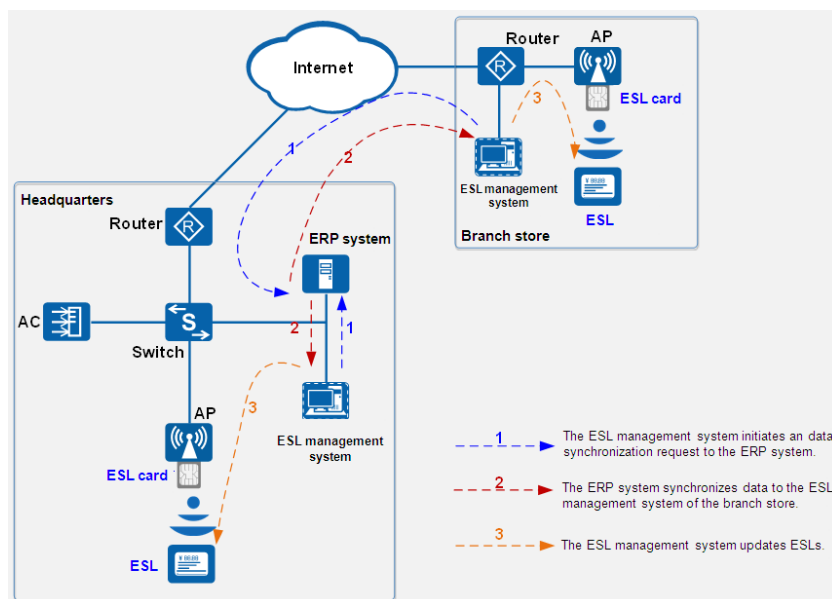

The ESL management system needs to interwork with the customer's enterprise resource planning (ERP) system, so that information such as product codes and prices can be synchronized to the ESL management system. The ESL operation process is as follows:

1. The ESL management system of each branch store requests data update and price change information from the headquarters' ERP system. Century can provide APIs for interworking with the customer's ERP system. Interconnection with the ERP system can also be implemented at the database level.
2. After obtaining the required data, the ESL management system delivers ESL update tasks to the ESL card according to the task plan. The ESL card caches data and waits for update requests sent by ESLs.
3. ESLs are low-power RFID terminals. Radio modules of ESLs periodically wake up and proactively check whether update tasks exist. If so, the radio modules obtain the update data and update the content to be displayed. If not, they enter the dormancy state and wait for the next wake-up cycle.

Century's ESL system uses RFID 2.4 GHz technology on the wireless side, which interferes with 2.4 GHz Wi-Fi signals. ESL usage scenarios have the following characteristics:

- ESL update after business hours: A survey conducted by ESL industry partners shows that ESL updates are implemented after business hours in most ESL scenarios. This approach prevents ESL updates from affecting normal business of shopping malls and avoids unnecessary customer complaints.
- ESL during business hours: Such scenario only occurs in some small stores such as bakeries with only dozens of ESLs and a small amount of service data.

Therefore, RFID and Wi-Fi services are often staggered in actual scenarios, so the interference between them is acceptable. Moreover, Century has set proper frequencies for different service processes, which avoids using commonly used Wi-Fi channels 1, 6, and 11.



---

# 4 Customer Benefits

---

## 1. Unified Portal

When Wi-Fi networks are deployed, issues such as wireless site selection, wired link backhaul, and site power supply need to be considered. A physical deployment scenario may involve different wireless technologies. If each wireless technology implements independent site selection, backhaul, and power supply, it would increase costs and bring construction and environmental challenges. Huawei's IoT Wi-Fi Convergence Solution provides users with Wi-Fi access and other connection modes such as Bluetooth and RFID. By offering a unified portal for Wi-Fi, Bluetooth, and RFID access, the solution enables these wireless technologies to share the same site, data backhaul link, and power supply. This significantly reduces the network construction cost and workload, and minimizes the impact on the surroundings.

## 2. Unified Management

IoT APs offer users unified management in the following ways:

- Unified management of the backhaul network. Built-in Bluetooth modules of IoT APs or external RFID modules in expansion slots can share the same backhaul links with Wi-Fi networks. This means that only one wired network needs to be deployed and managed.
- Unified site management. Built-in Bluetooth modules of IoT APs or external RFID modules in expansion slots can share the same IoT site. In this way, only one physical site needs to be managed and maintained to implement management and maintenance of Wi-Fi, Bluetooth, and RFID sites.

## 3. Scalability

In addition to Wi-Fi functions and built-in Bluetooth modules, an IoT AP also provides extensive external interfaces, including a PoE out Ethernet interface, a USB interface, and three Mini PCIe interfaces. These interfaces deliver flexible scalability for network construction. For example, a PoE IoT module can be expanded through the PoE out Ethernet interface, and an RFID module can be expanded through the USB interface.